

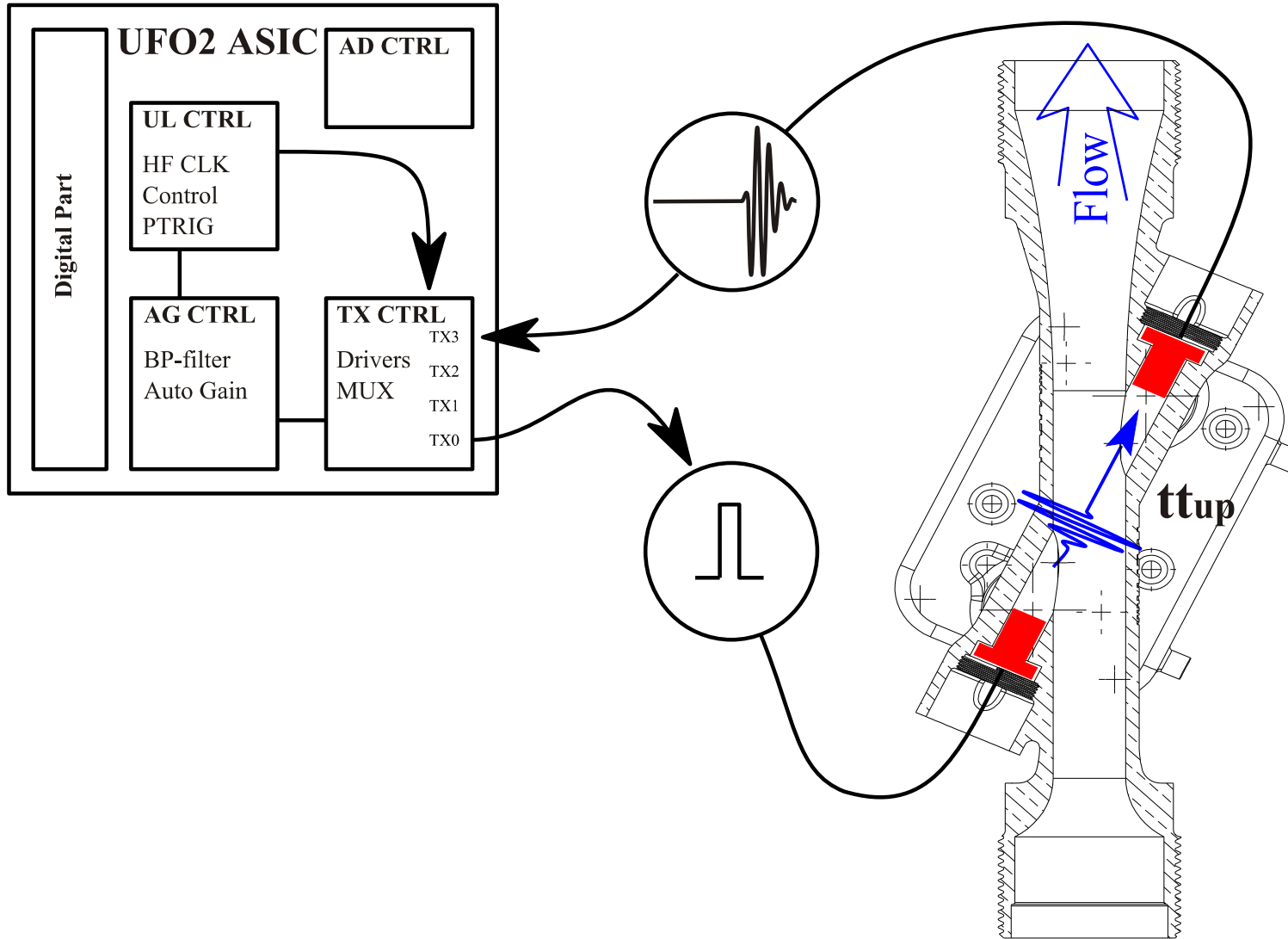

D-FLOW 
UF02-B1-P
MSC80014
1236

The measurement system



General Principal of Operation

The transit times

$t_{dn} = L / (s_{os} - v)$ the downstream transducer in RX mode (upstream transit time)

$t_{up} = L / (s_{os} + v)$ the upstream transducer in TX mode (downstream transit time)

Calibration

“ d_{zc} ” static correction factor for zero flow

“ d_{sos} ” static correction factor for speed of sound

“ $k(Re)$ ” calibration curve correction

Measurements

$$v = L / 2 \left\{ 1 / (t_{up} - d_{sos} + d_{zc}) - 1 / (t_{dn} - d_{sos} - d_{zc}) \right\}$$

$$V_{true} = vk(Re)$$

$$s_{os} = 2L / (t_{up} + t_{dn} - 2d_{sos})$$

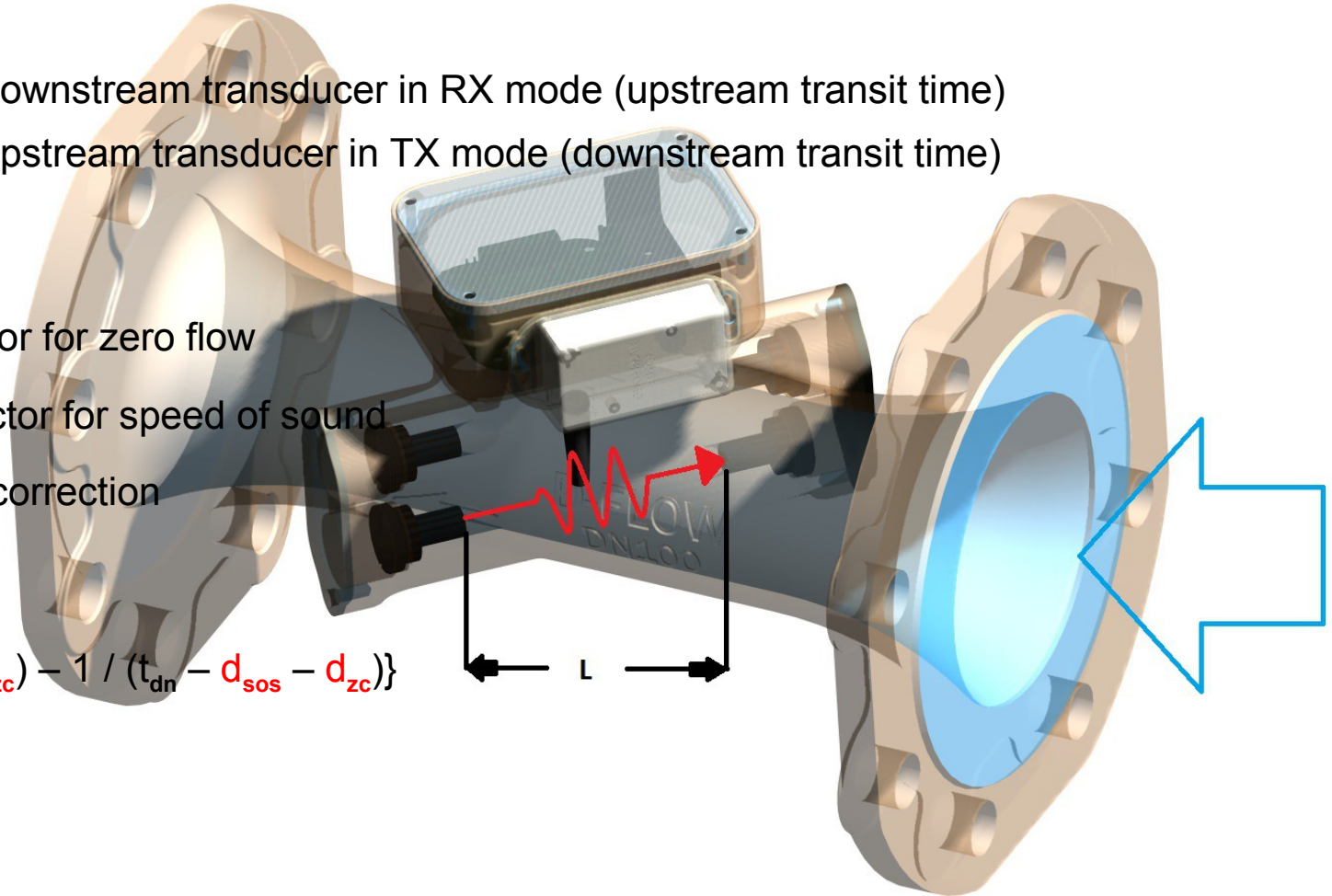

Automatic Gain Calibration:

Automatic Gain Calibration

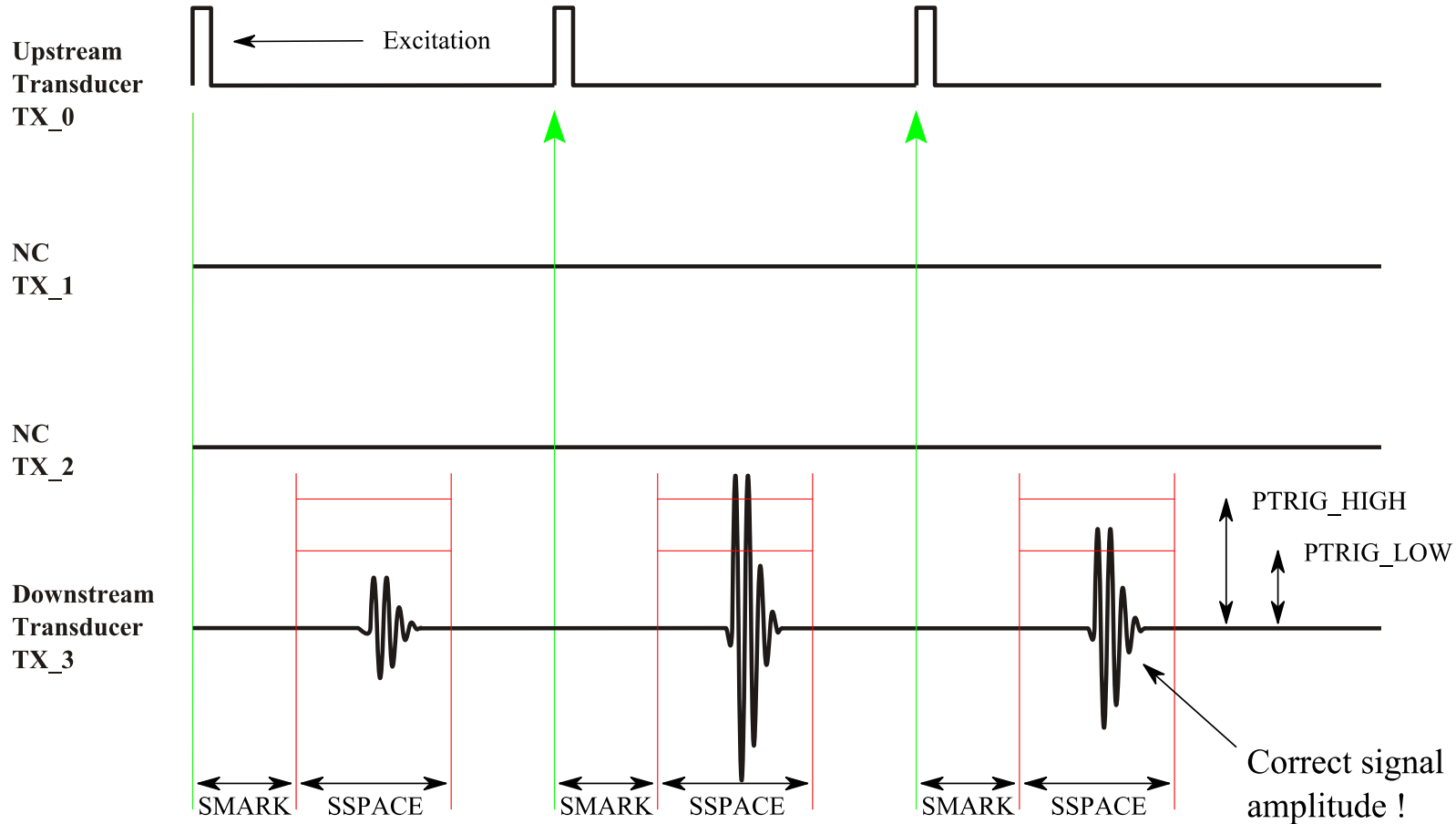

Measurement Mode 1:

Mode 1: Two single ended transducers

Numbers of sing-around loops, $N = 1$ (single shot) or 2

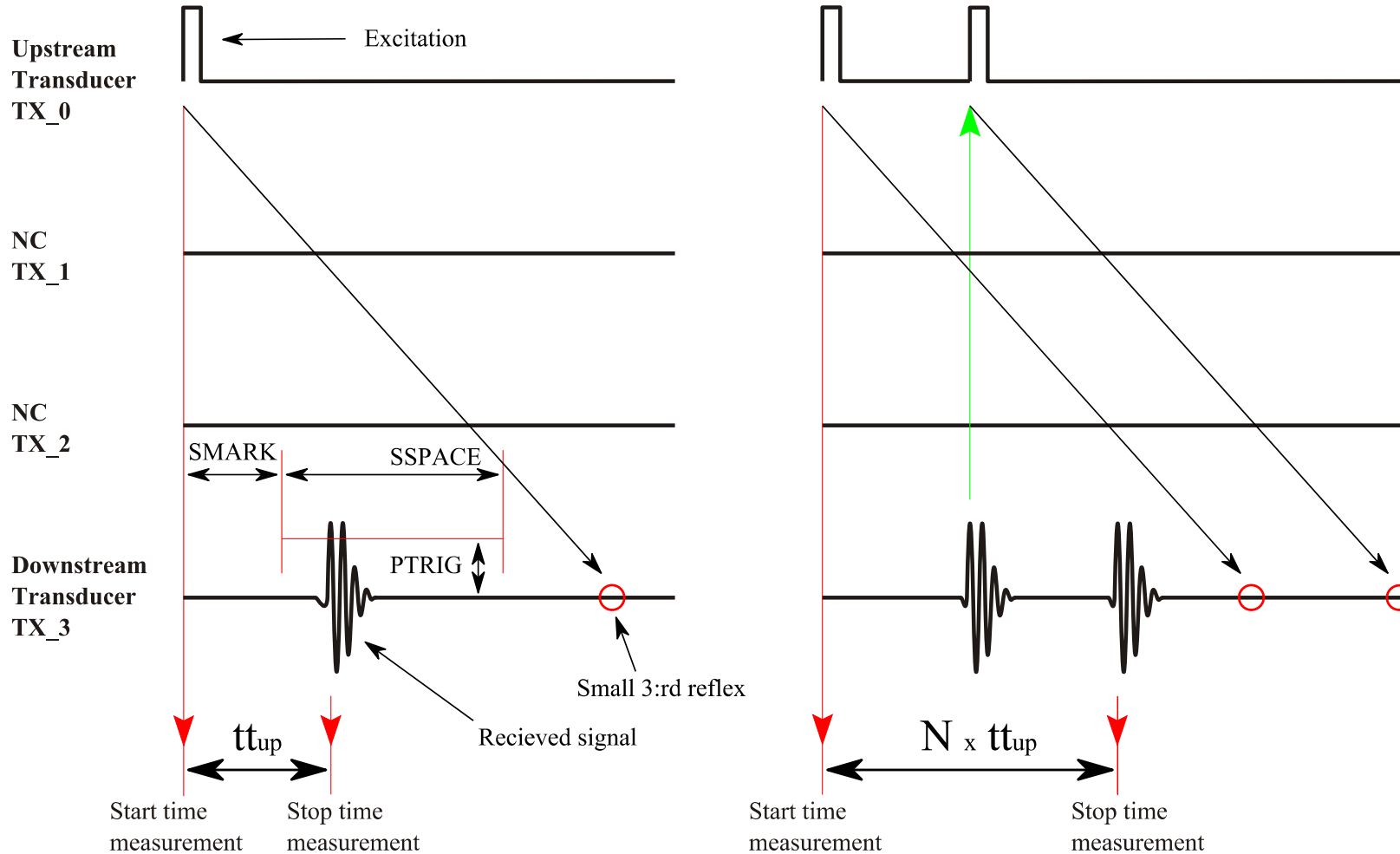

Measurement Mode 2:

Mode 2: Four single ended transducers
Number of sing-around loops, $N = n * 4$

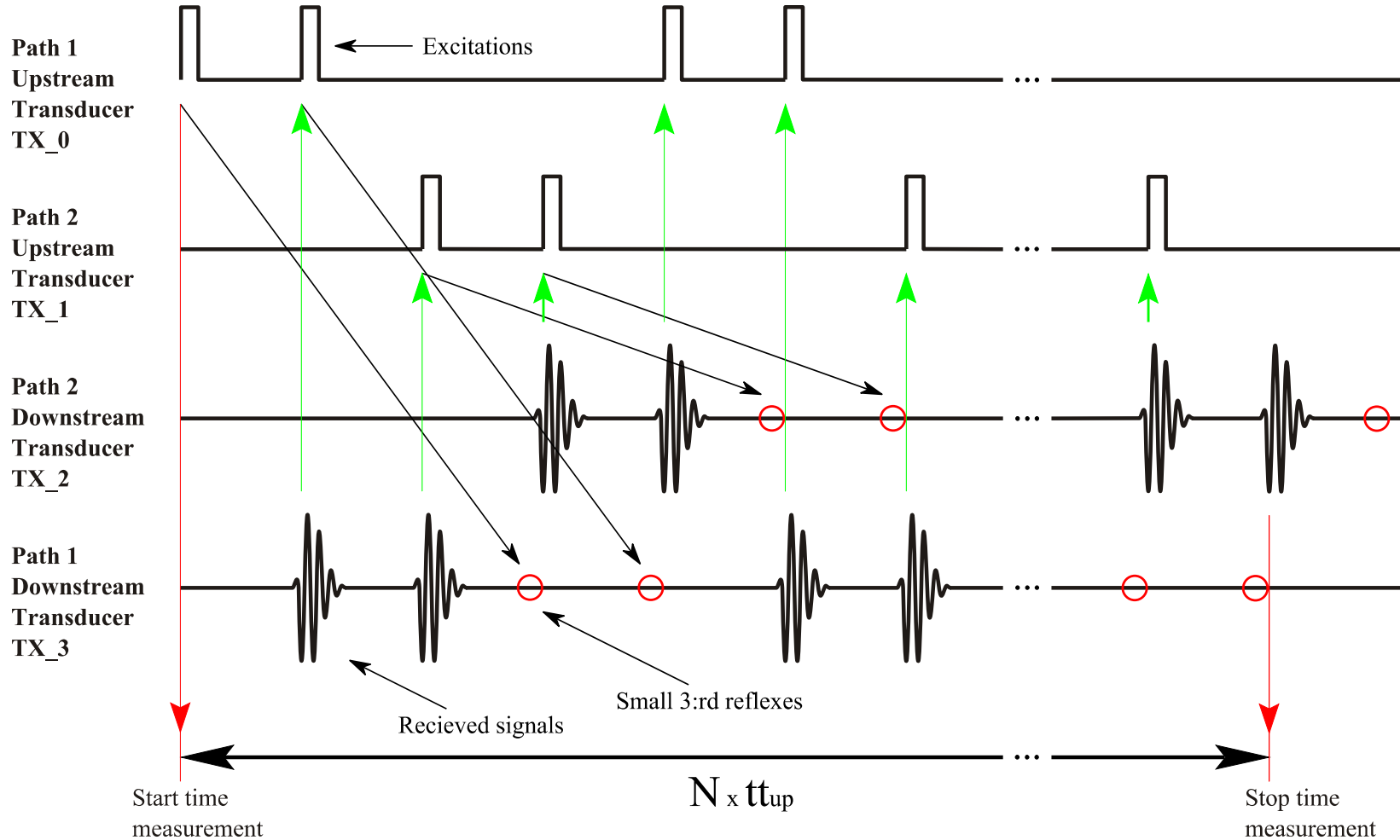

Measurement Mode 3:

Mode 3: Two differential transducers

Number of sing-around loops, $N = n * 8 + 4$

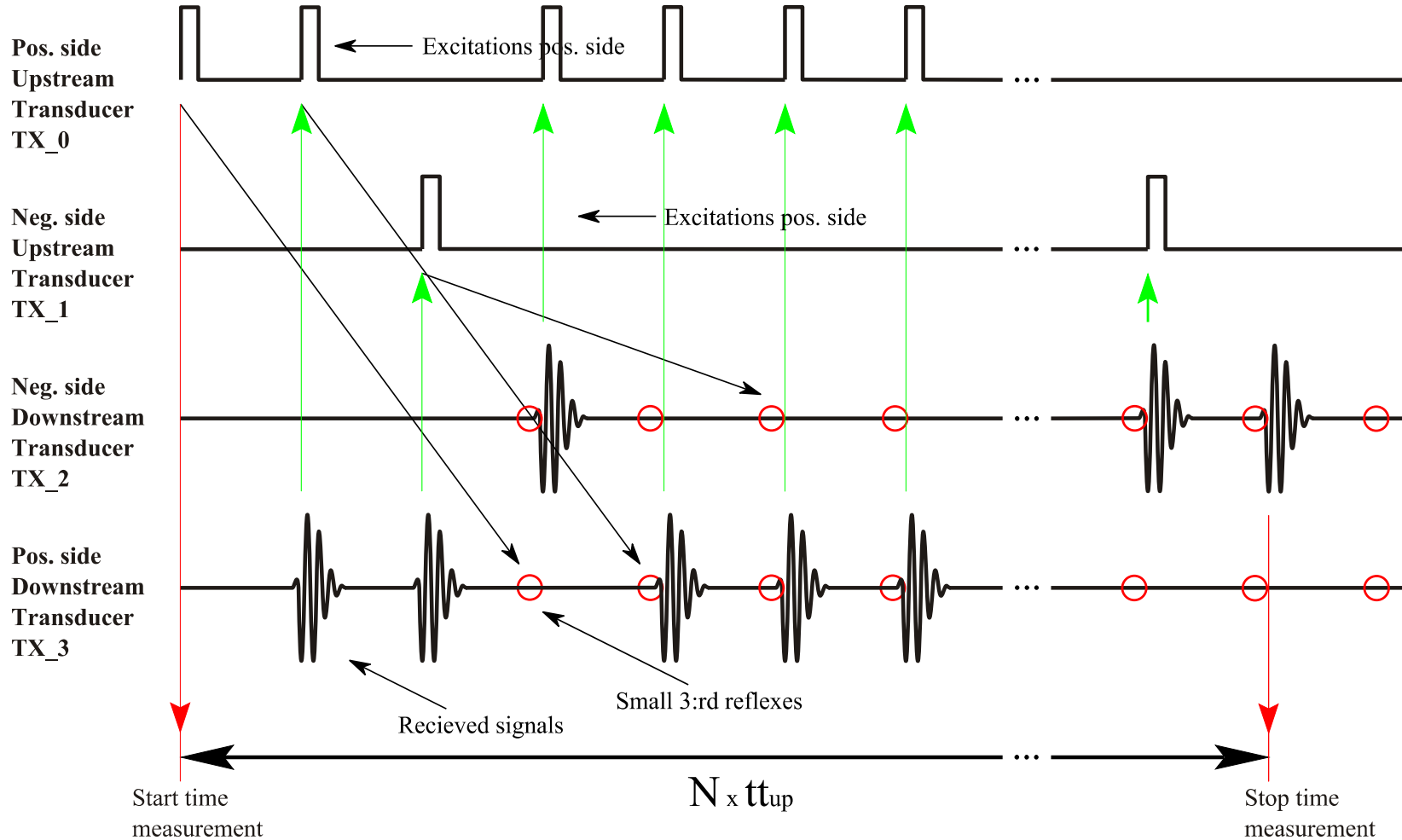

DN20 Evaluation Meter Design

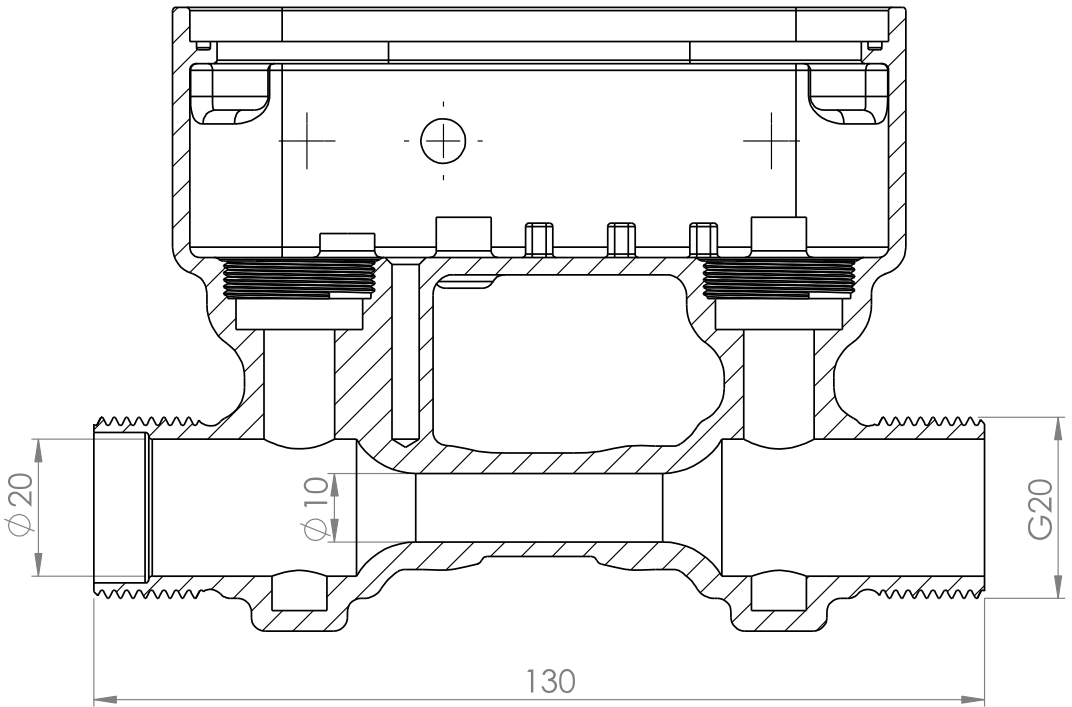
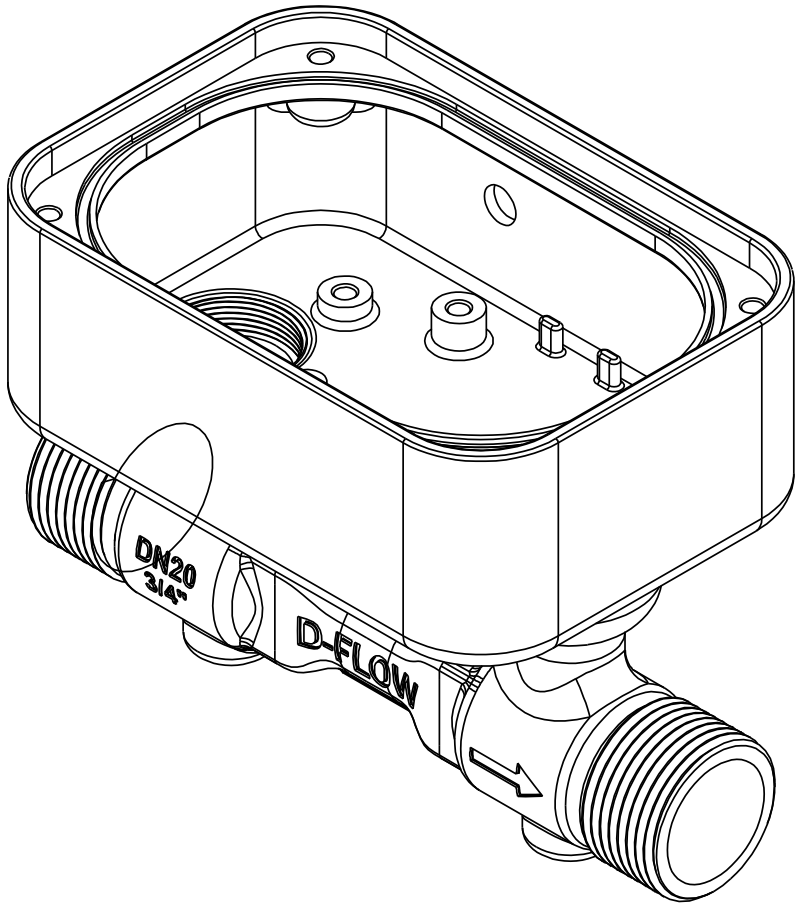

SECTION B-B
SCALE 1 : 1

DN32 Evaluation Meter Design

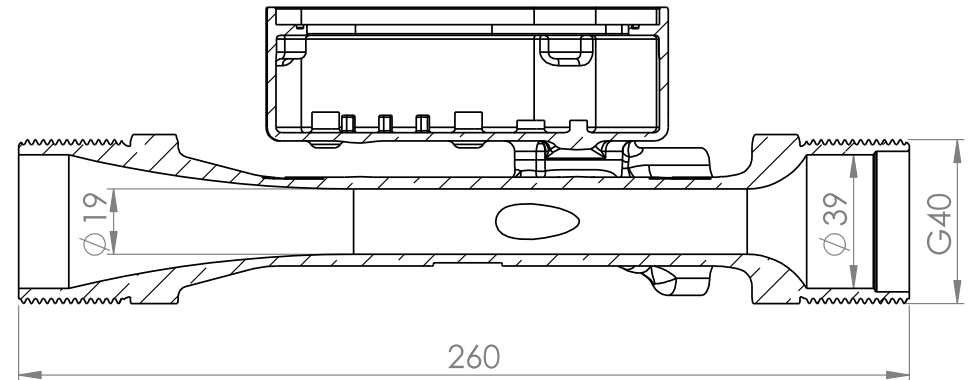
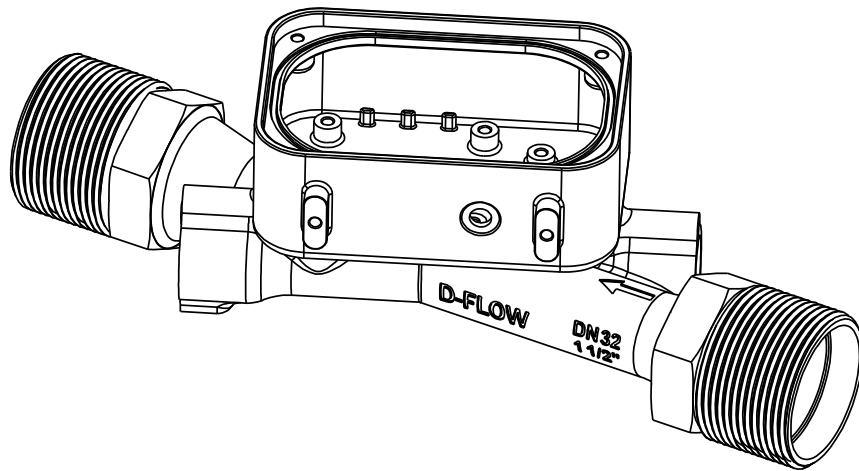

SECTION A-A
SCALE 1 : 2

DN100 Evaluation Meter Design

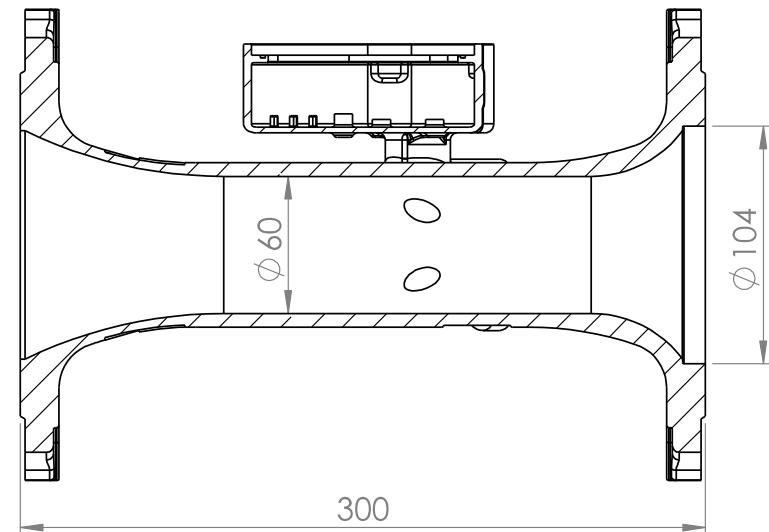
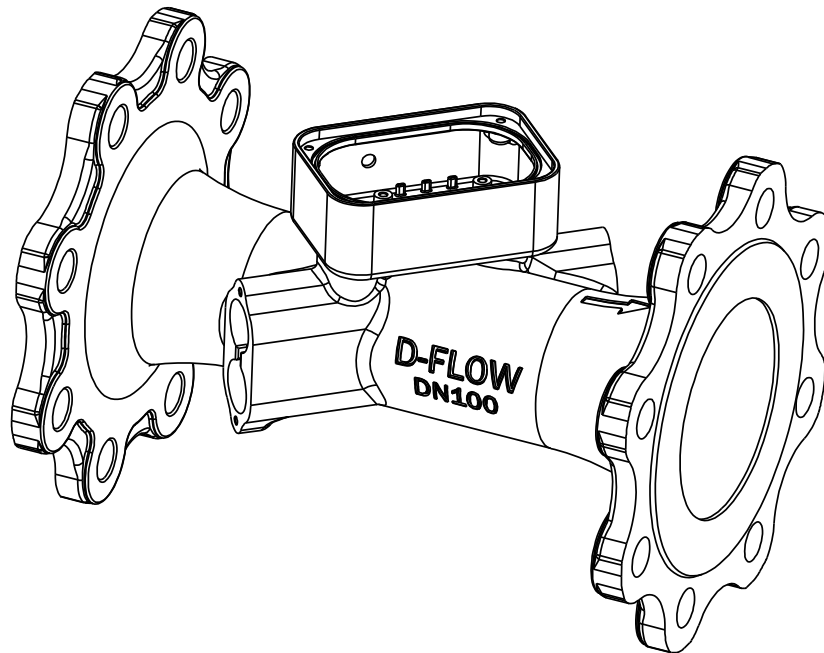

SECTION A-A
SCALE 1 : 3

DN20 Performance Example

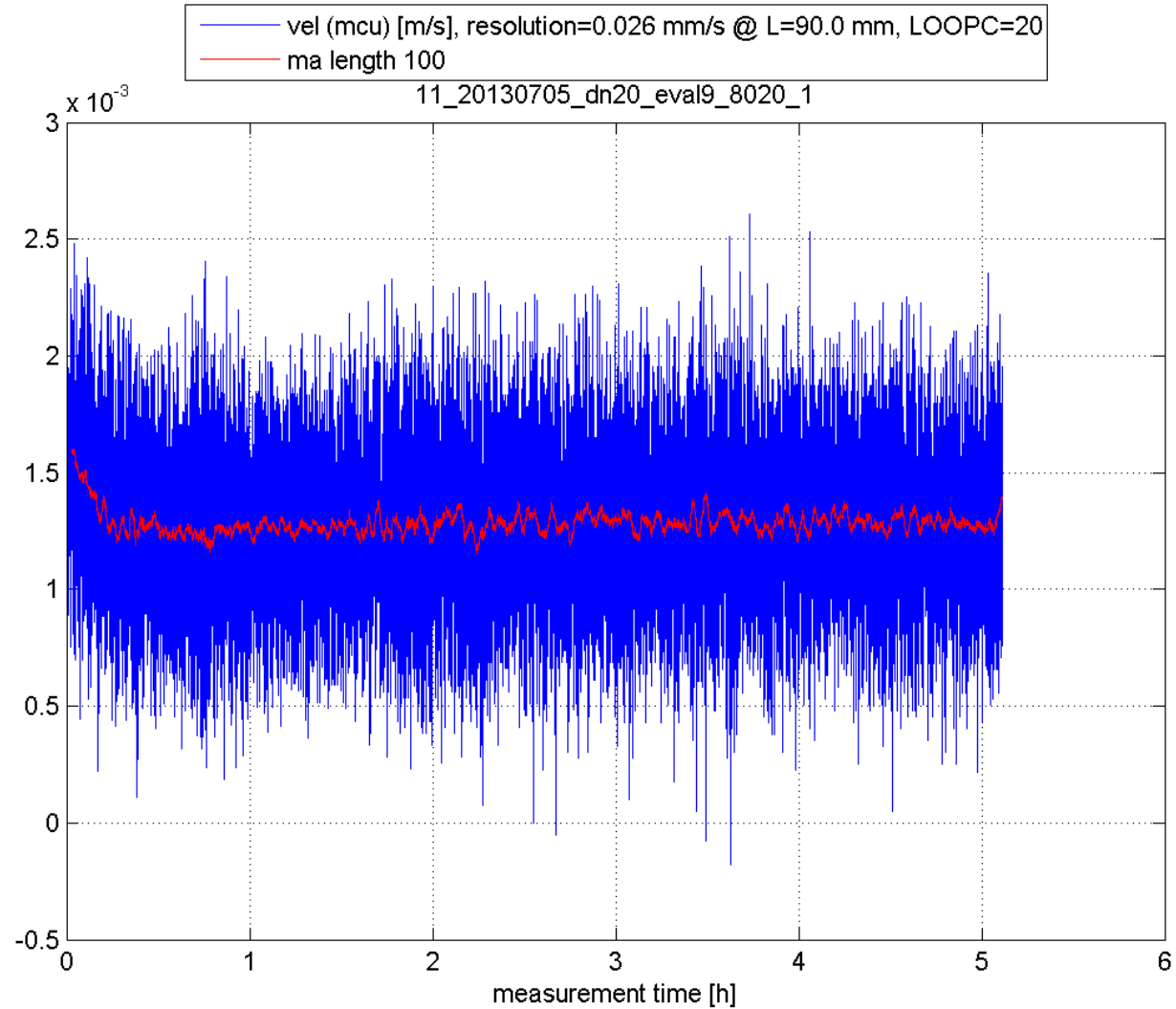

DN20 Performance Example

DN20 evaluation meter 9 with conditioner (EN 1434 example)

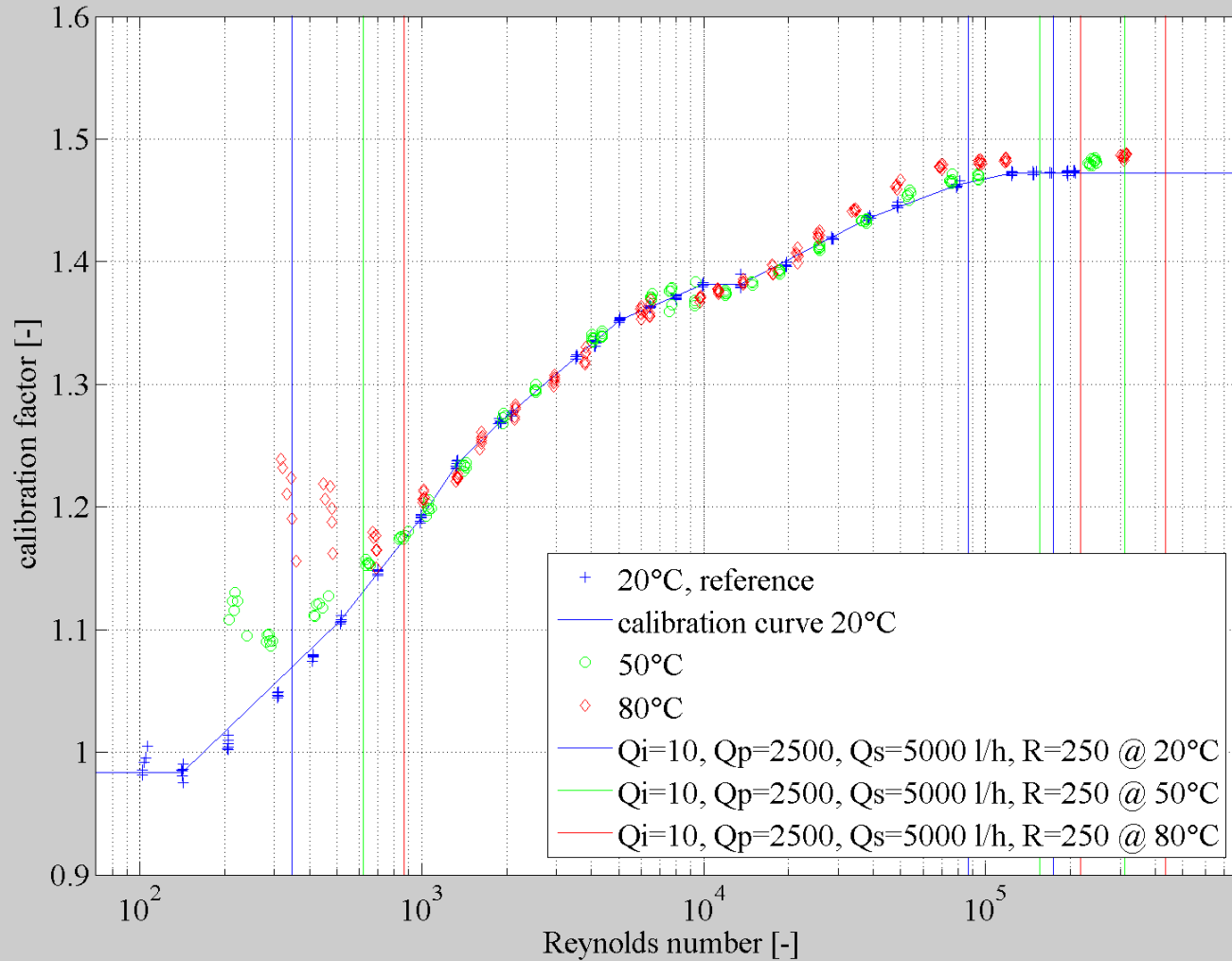

DN32 Performance Example

DN32 evaluation meter 1 (EN 1434 example)

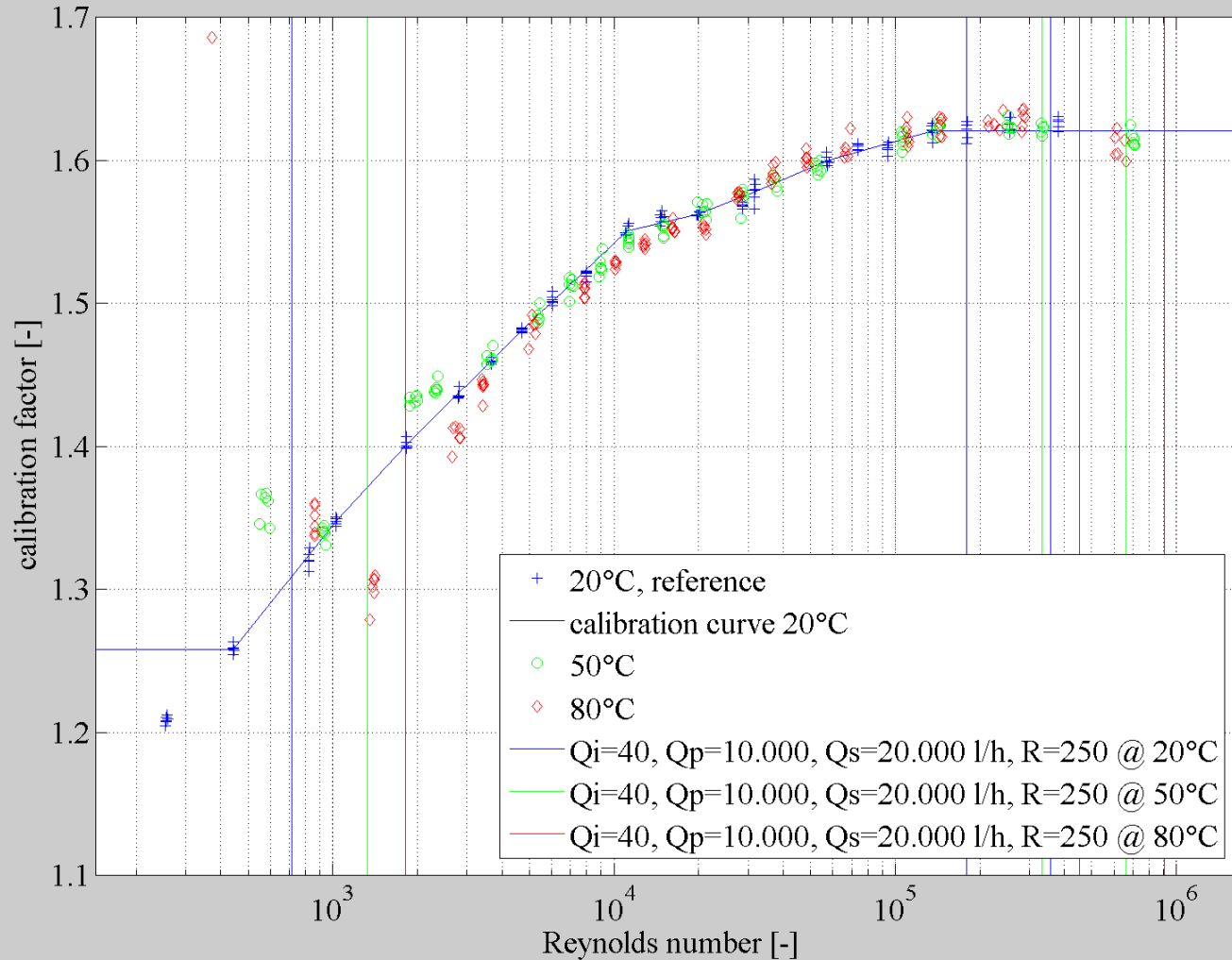

DN100 Performance Example

DN100 evaluation meter 2 (EN 1434 example)

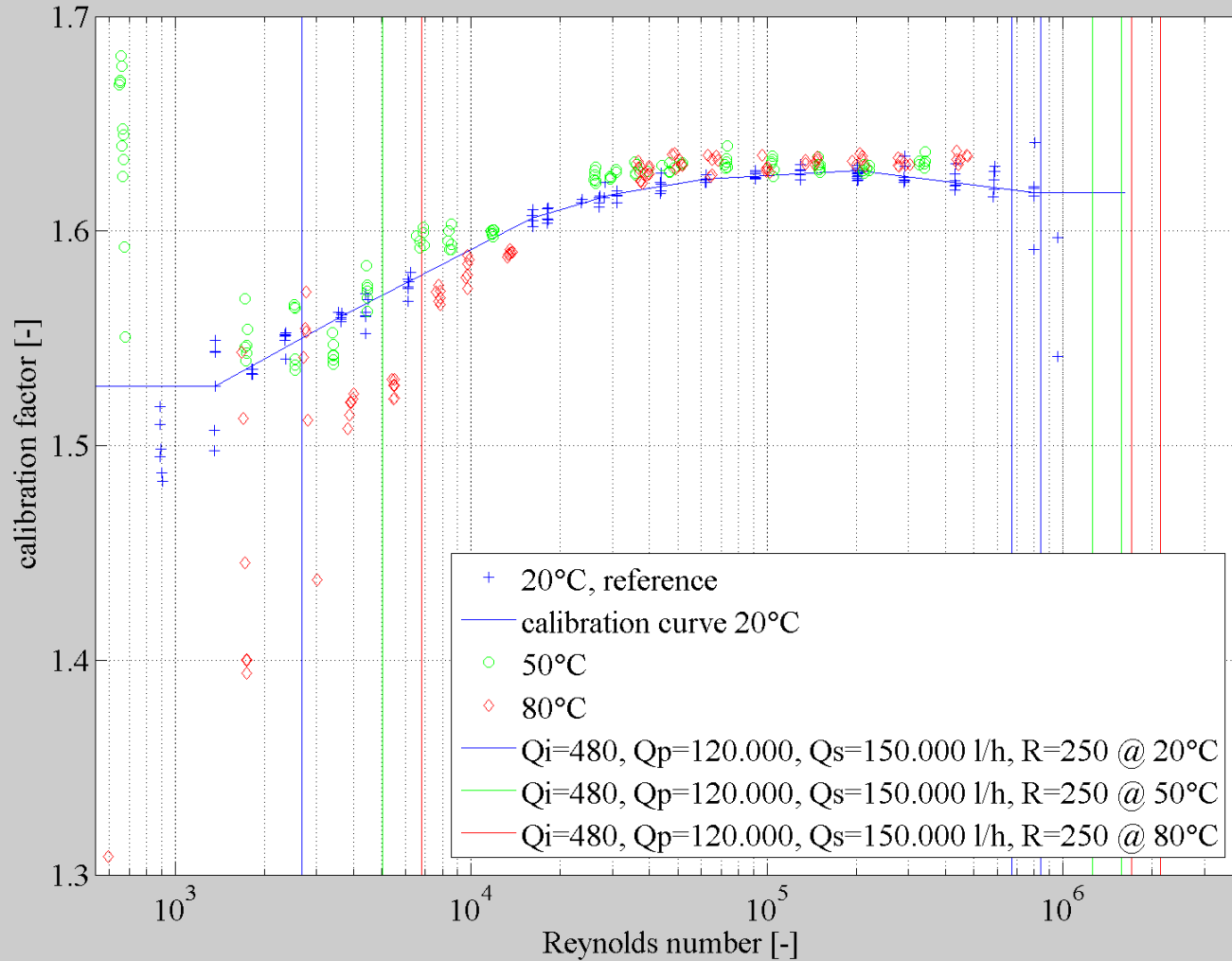

DN20 Performance Example

DN20 evaluation meter 9 with conditioner (EN 1434 example)

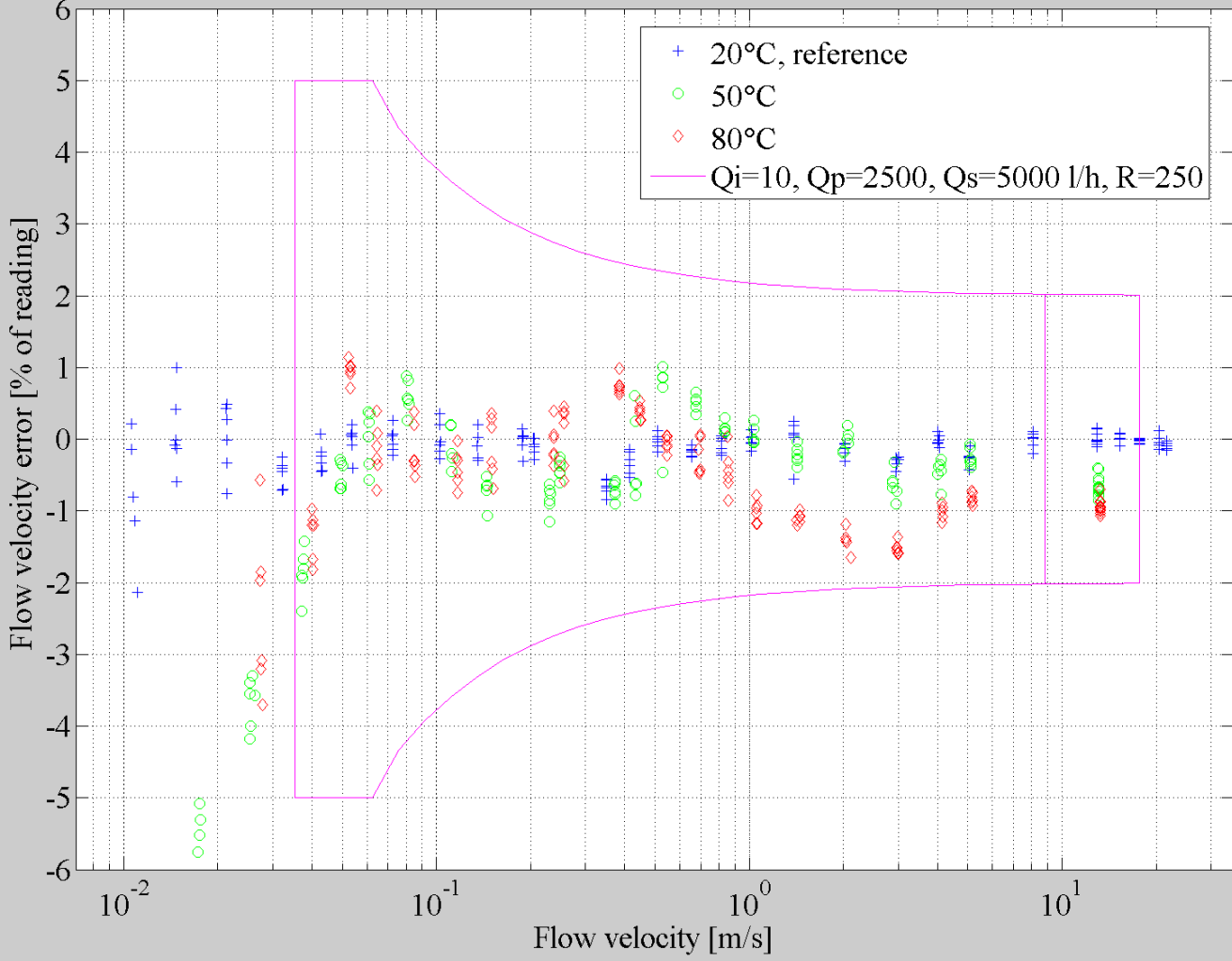

DN32 Performance Example

DN32 evaluation meter 1 (EN 1434 example)

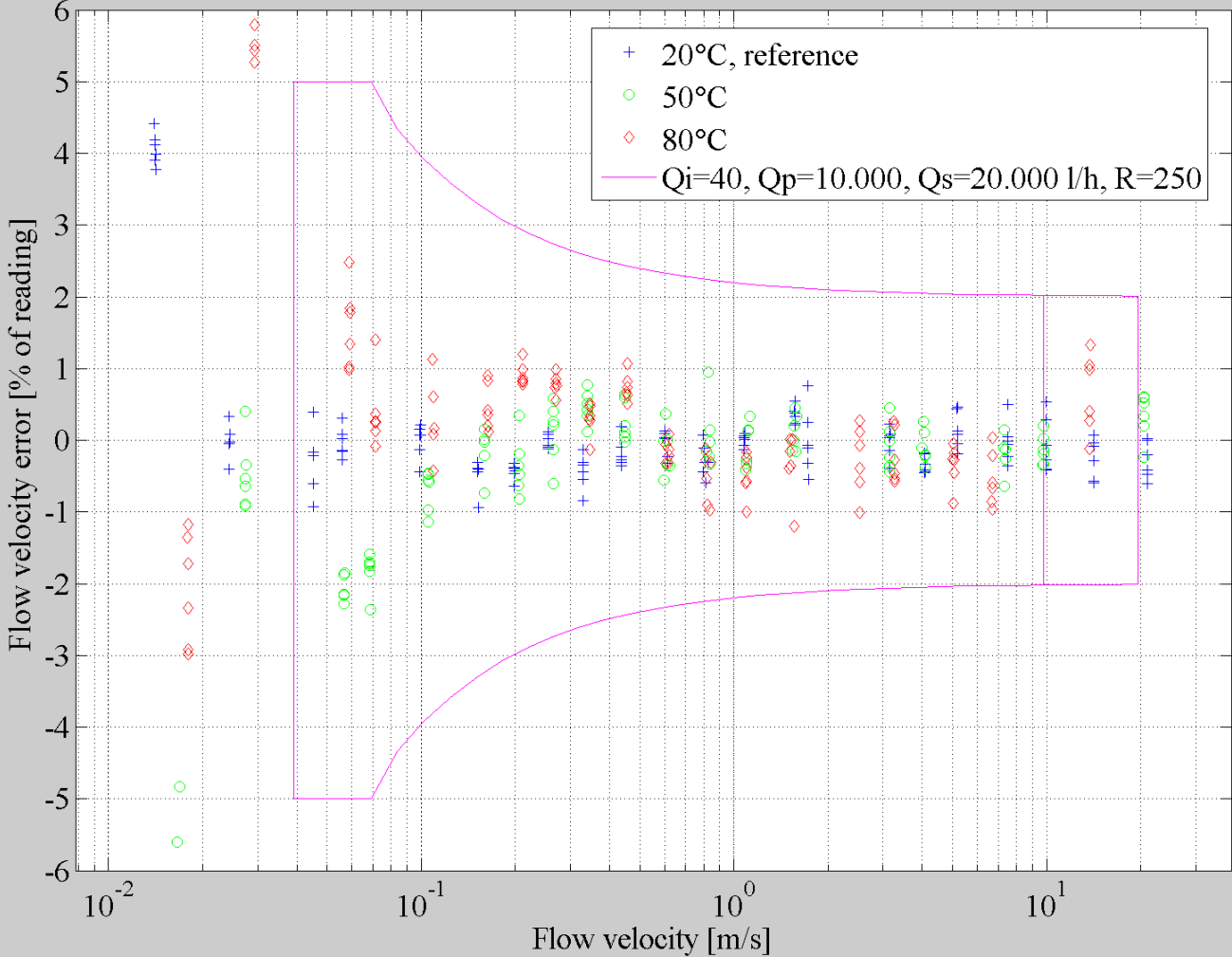

DN100 Performance Example

DN100 evaluation meter 2 (EN 1434 example)

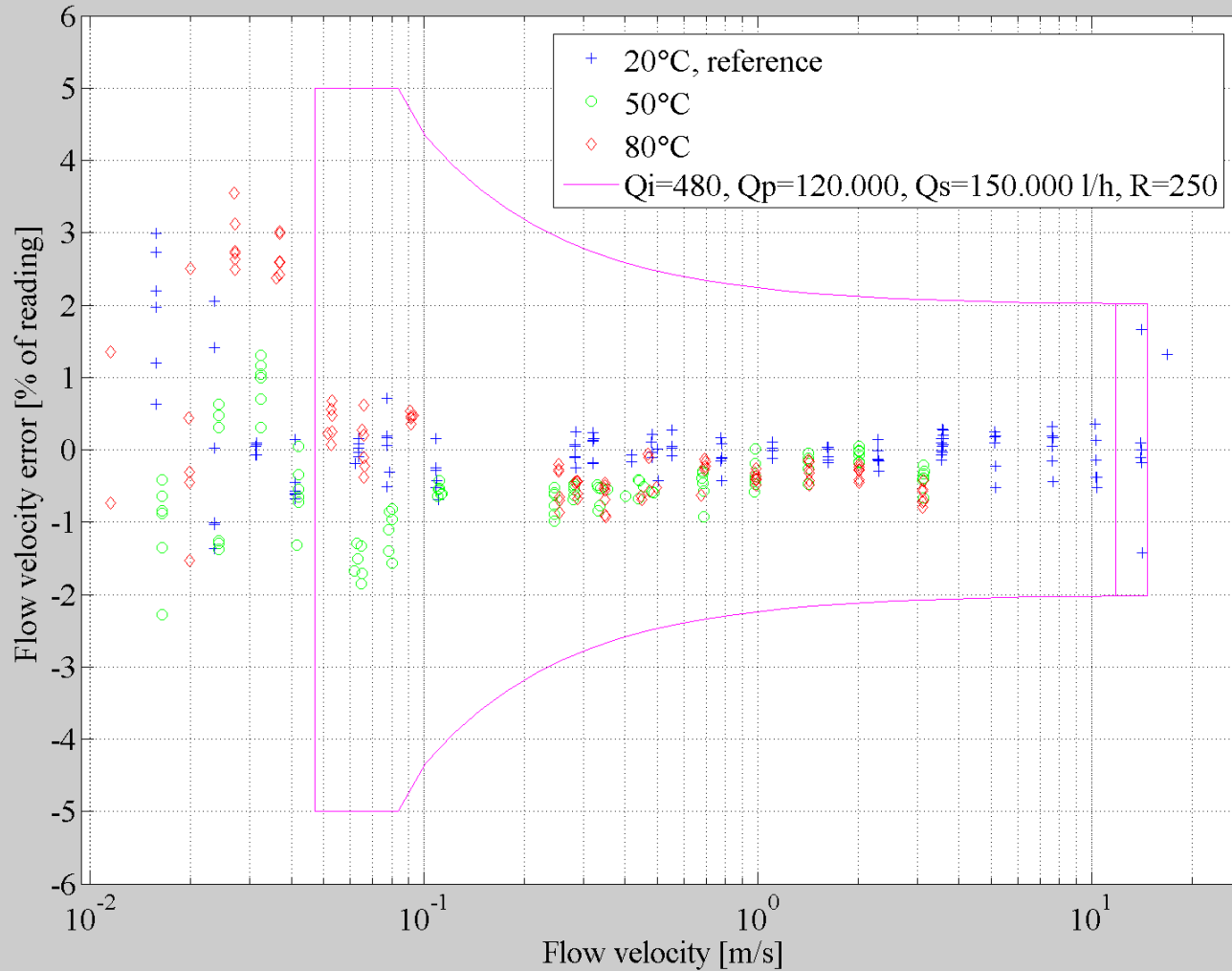

DN20 Performance Example

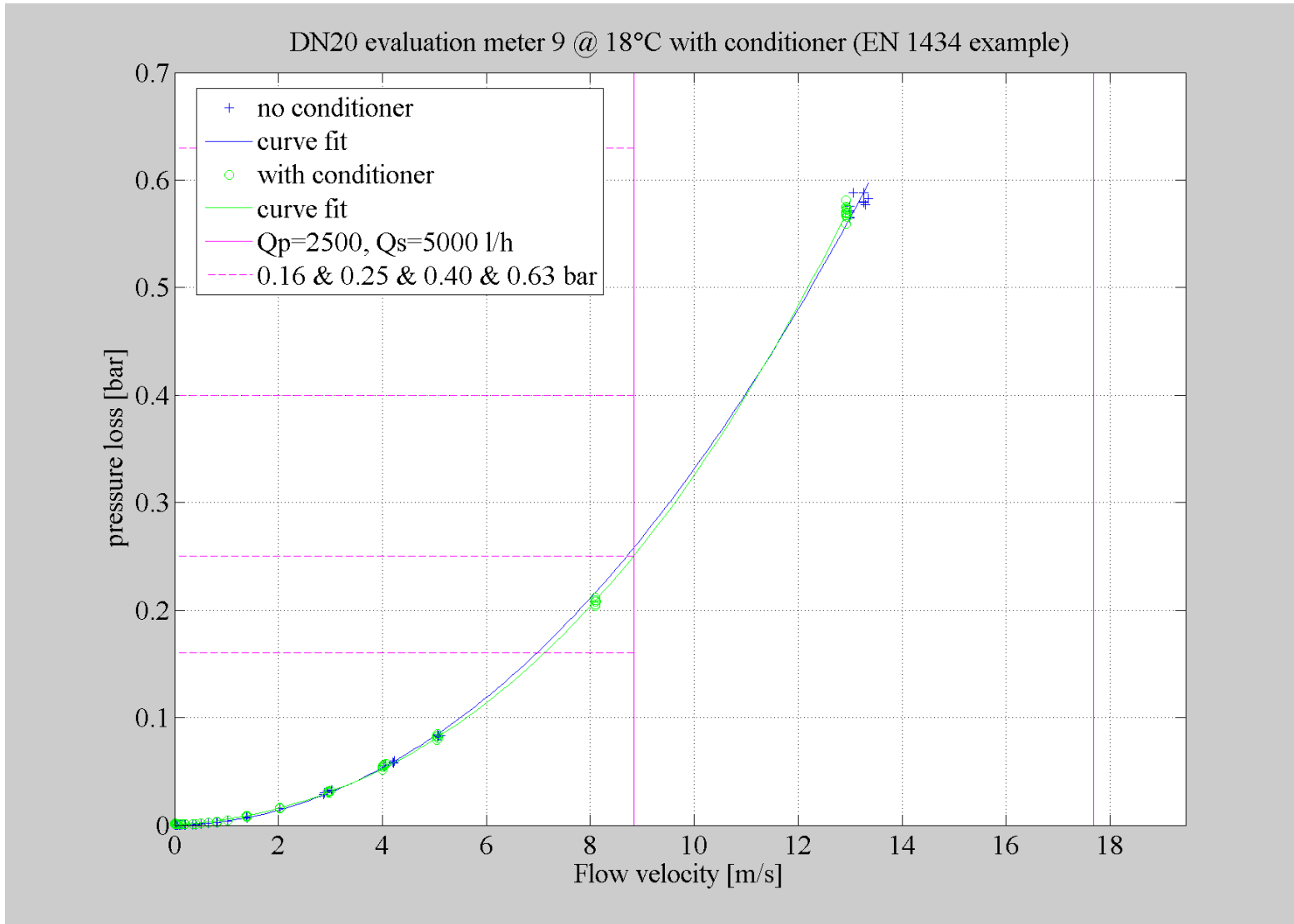

DN32 Performance Example

DN32 evaluation meter 1 @ 18°C (EN 1434 example)

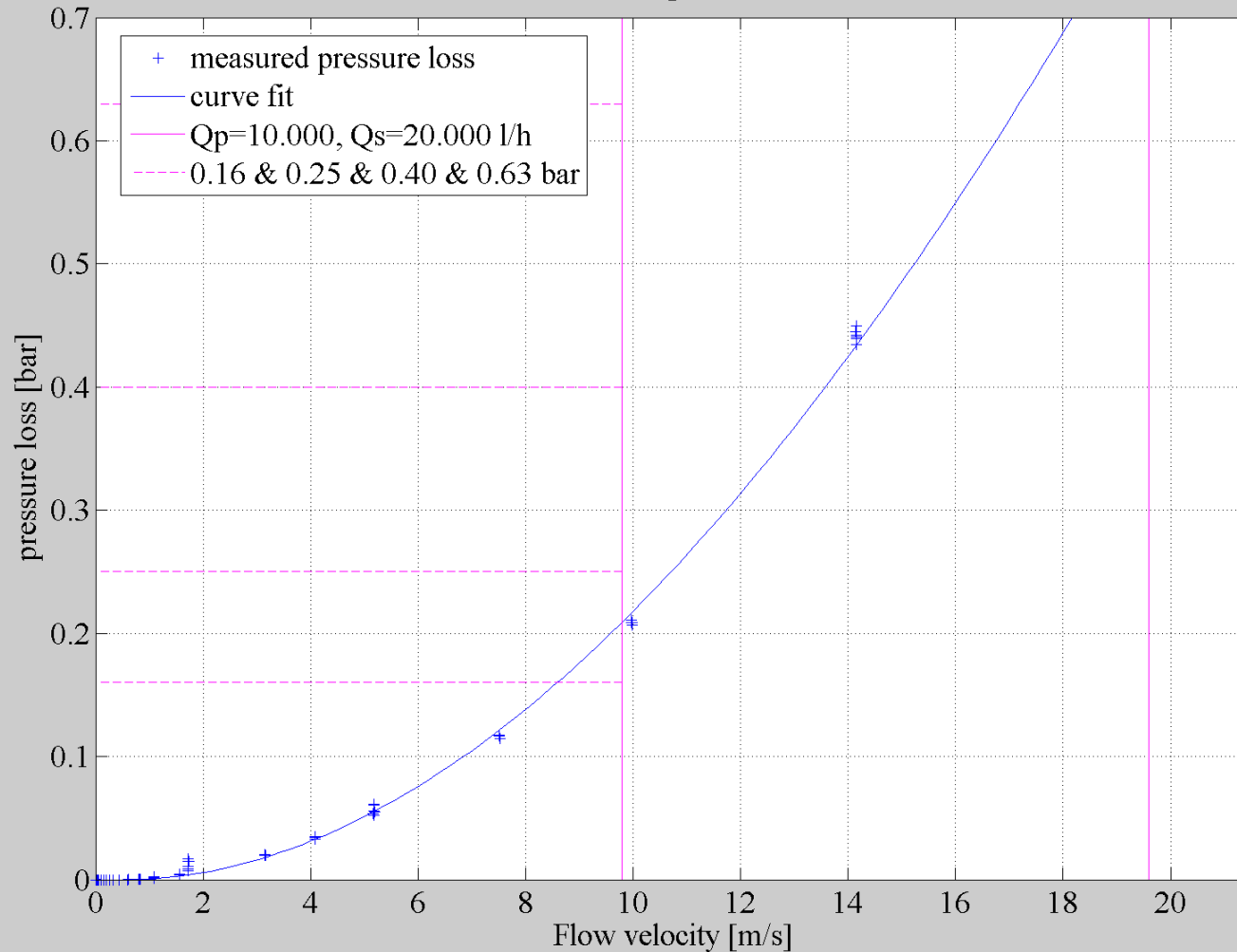

DN100 Performance Example

DN100 evaluation meter 2 @ 18°C (EN 1434 example)

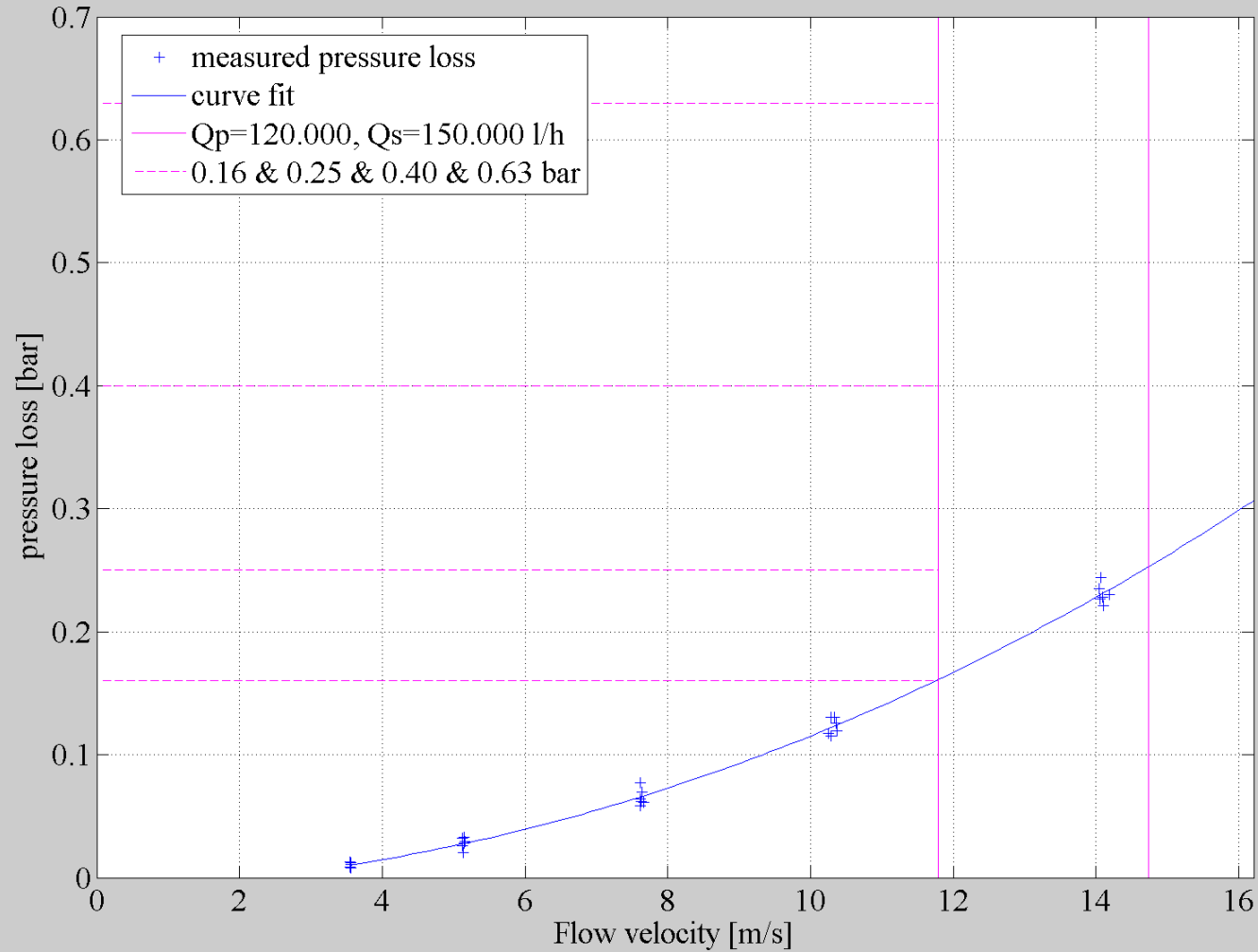

D-Flow power consumption

Static

- Sleep mode (quiescent current) 10uA
- Typical IDLE, microcontroller on 6mA

No temp @ 40mm, 1Hz

- LOOPC=1 21uA
- LOOPC=20 24uA

Frequency @ 40mm, LOOPC=1

- 0.5 Hz 15uA
- 1 Hz 21uA
- 2 Hz 34uA

With one PT1000 @ 40mm, 1Hz, LOOPC=1

- Sinc filter, 25uA (14bit resolution, 11bit conv time)

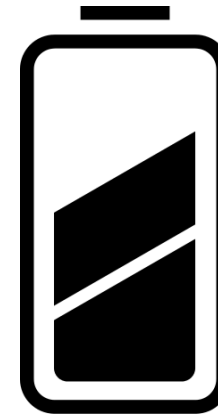

D-Flow temperature

Features

- Differential measurements
- Absolute measurement
- PT100 - PT1000 (-40°C - 190°C)
- 2, 3 or 4 wire interface
- Adj current 32uA – 4mA
- Adj Gain settings (input 1V +/- 0.65V at gain=1)
- Internal temperature sensor
- External voltage input
- Battery voltage sensing

Performance

- Absolute accuracy 0.2°C
- Differential measurement $\pm 0.1^\circ\text{C}$
- On chip sensor $\pm 5^\circ\text{C}$ (increase accuracy with calibration)

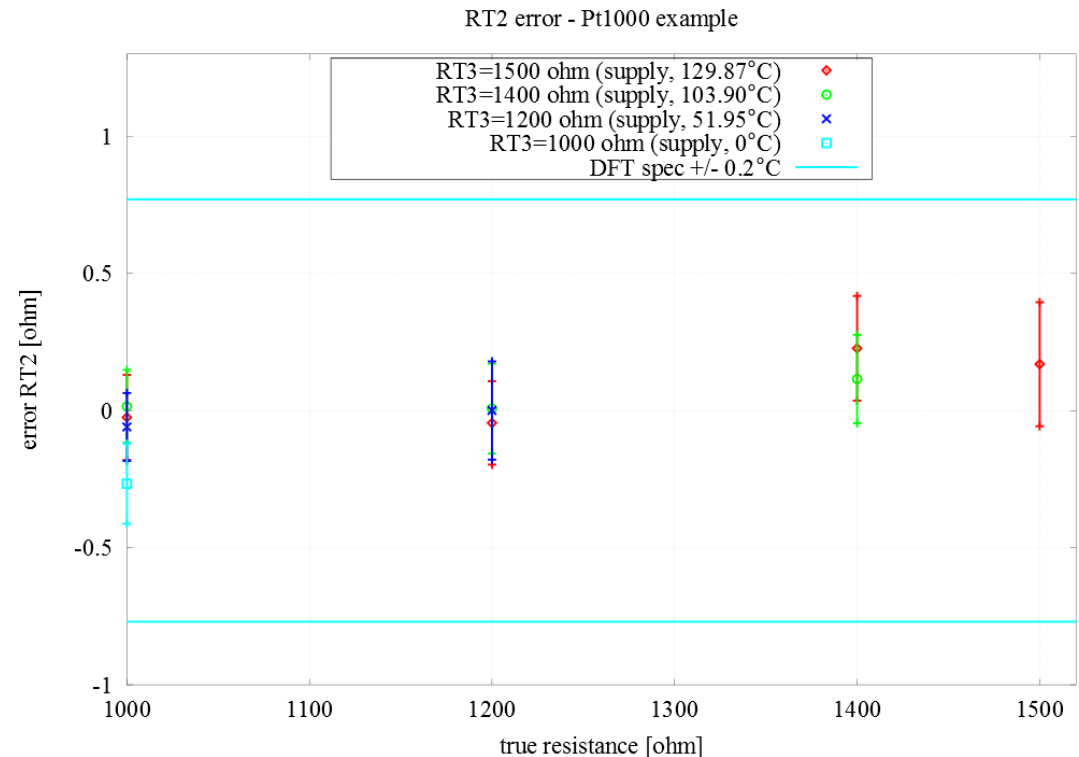



D-FLOW 
UF02-B1-P
MSC80014
1236