

REVISION HISTORY			
REV	DESCRIPTION	DATE	APPROVED

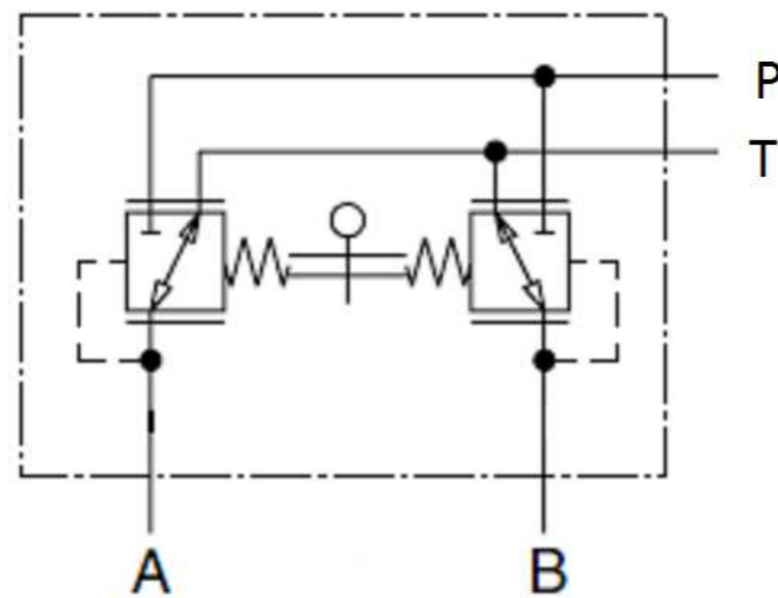

PILOT CONTROLLER

PART No: PCL-1

PRESSURE RANGE: 1-60 Bar

FLOW RATE: Max 15 L/min

PORTS: SAE-6

MATERIAL: CAST IRON BODY,

STEEL LEVER STEM,

PLASTIC KNOB & EPDM BOOT

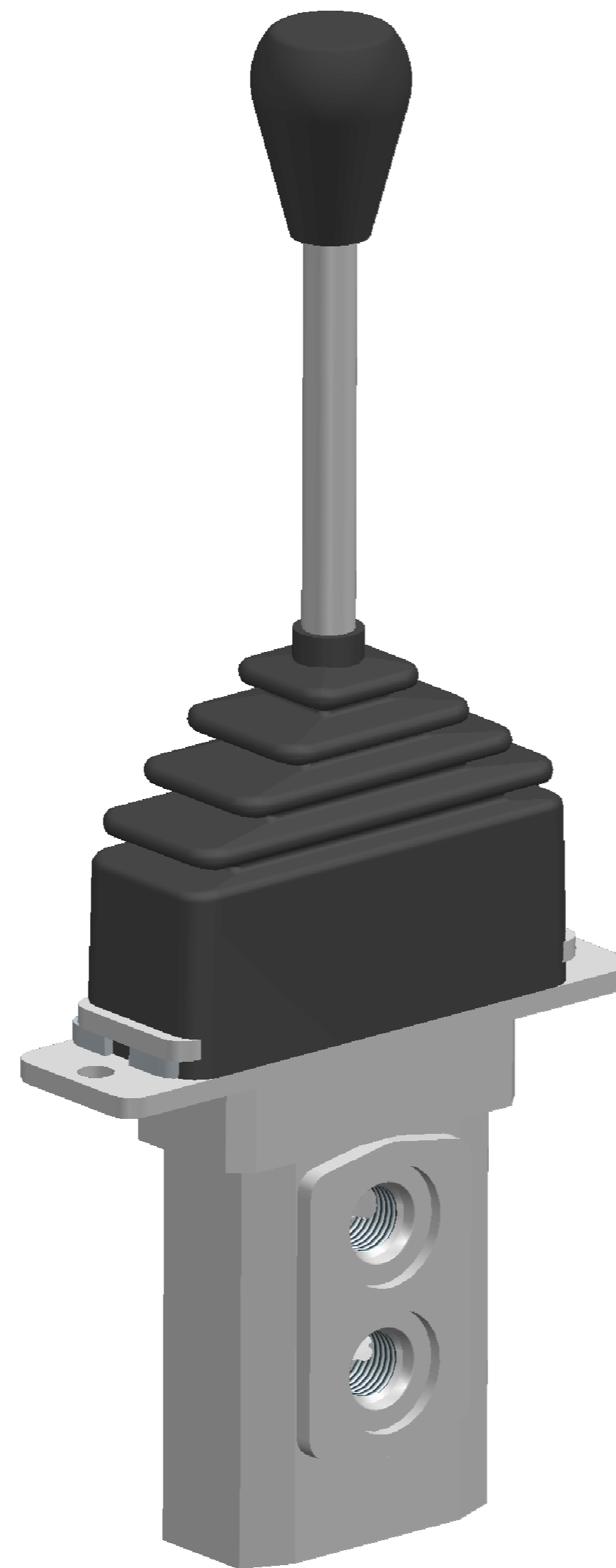

	NAME	DATE	PREMAC	
DRAWN	Dan	09/27/19		
APPROVED			TITLE	
MATERIAL				
TREATMENT				
UNLESS OTHERWISE SPECIFIED DIMENSIONS ARE IN MILLIMETERS			SIZE A4	DWG NO
1 ST ANGLE ANGLES ±0.1°			FILE NAME: Pilot Valve.dft	REV
2 PL ±0.02 3 PL ±0.005			SCALE:	WEIGHT:
			SHEET 1 OF 1	