

REVISION HISTORY			
REV	DESCRIPTION	DATE	APPROVED

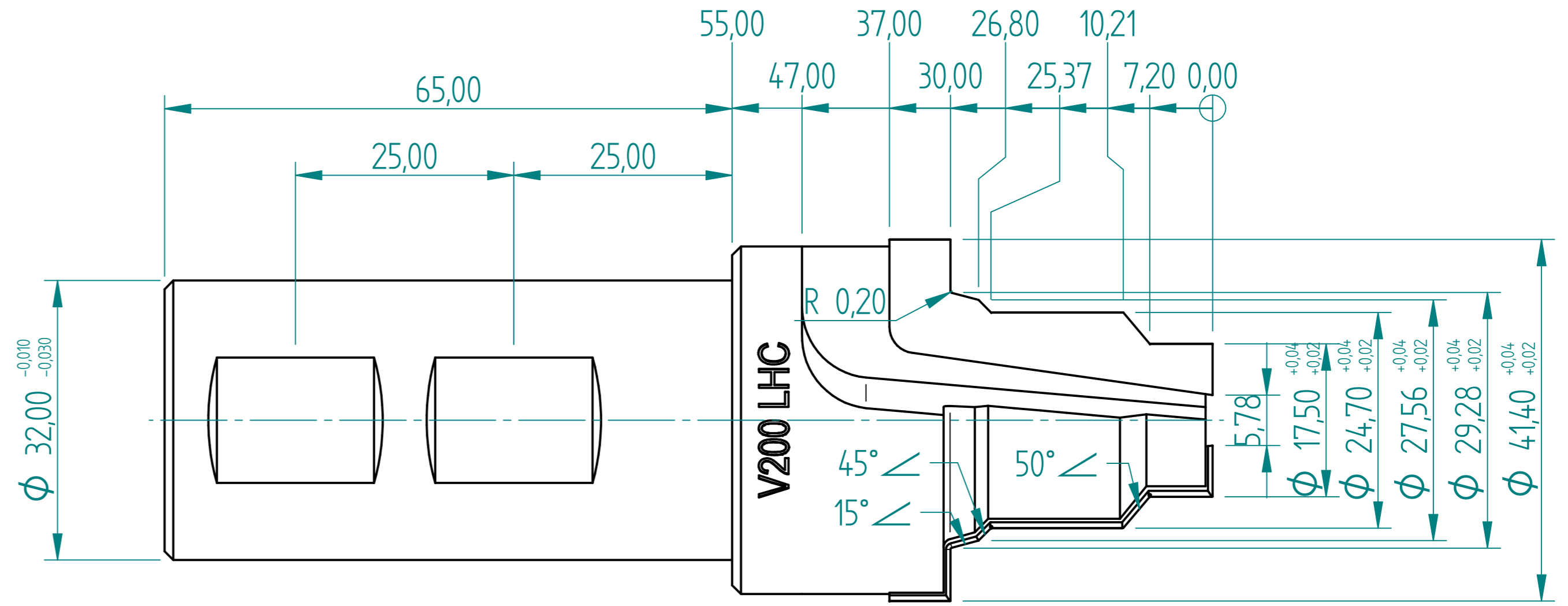

CUTTING SIZES

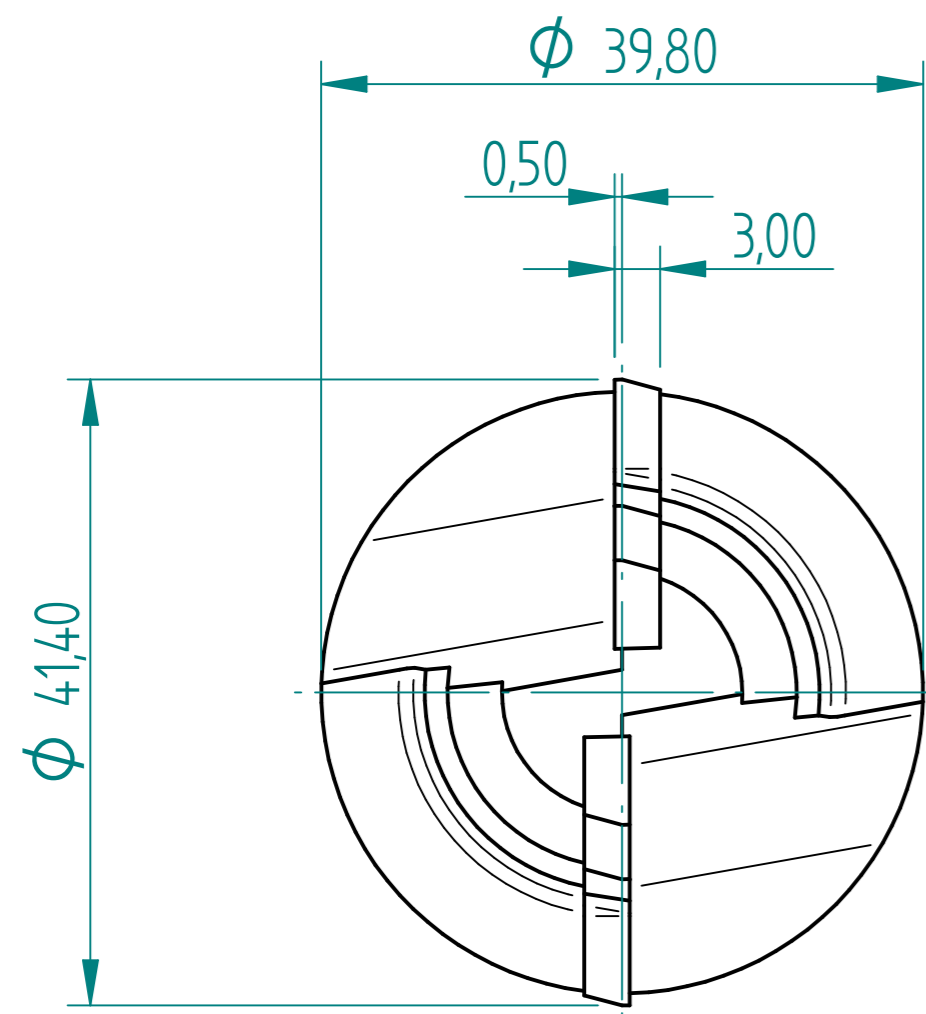
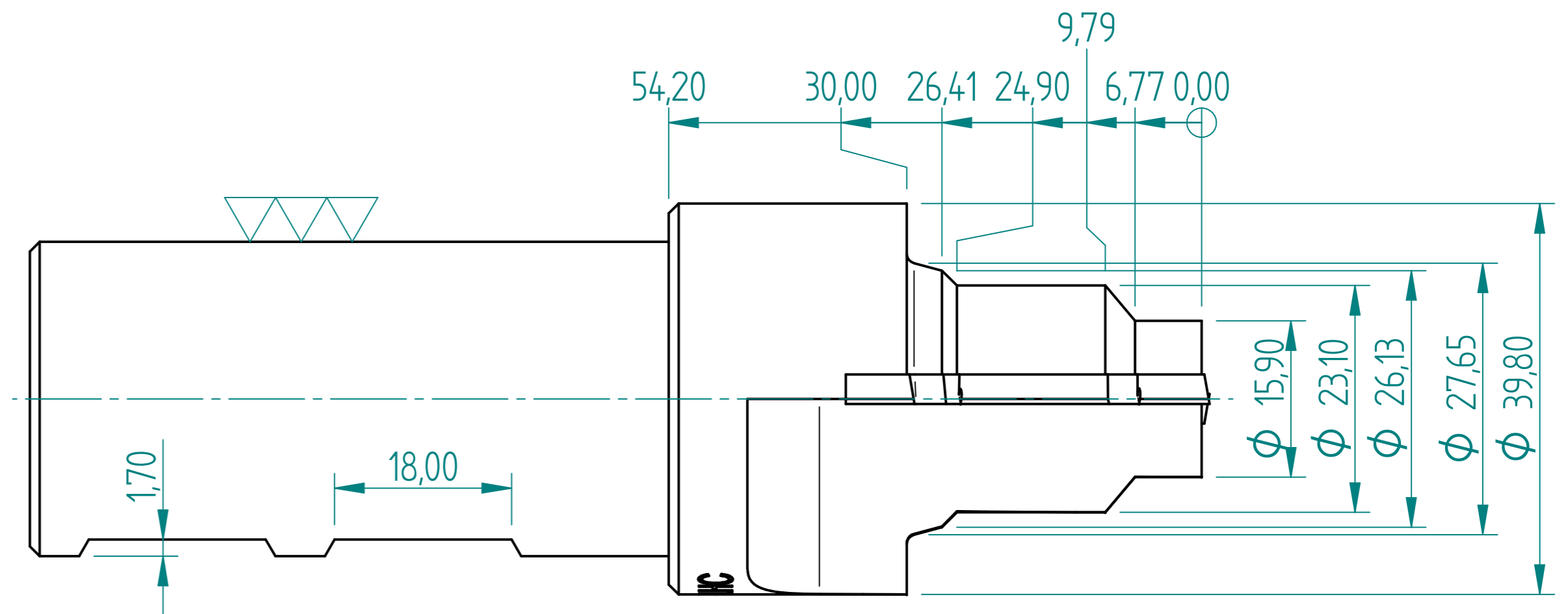
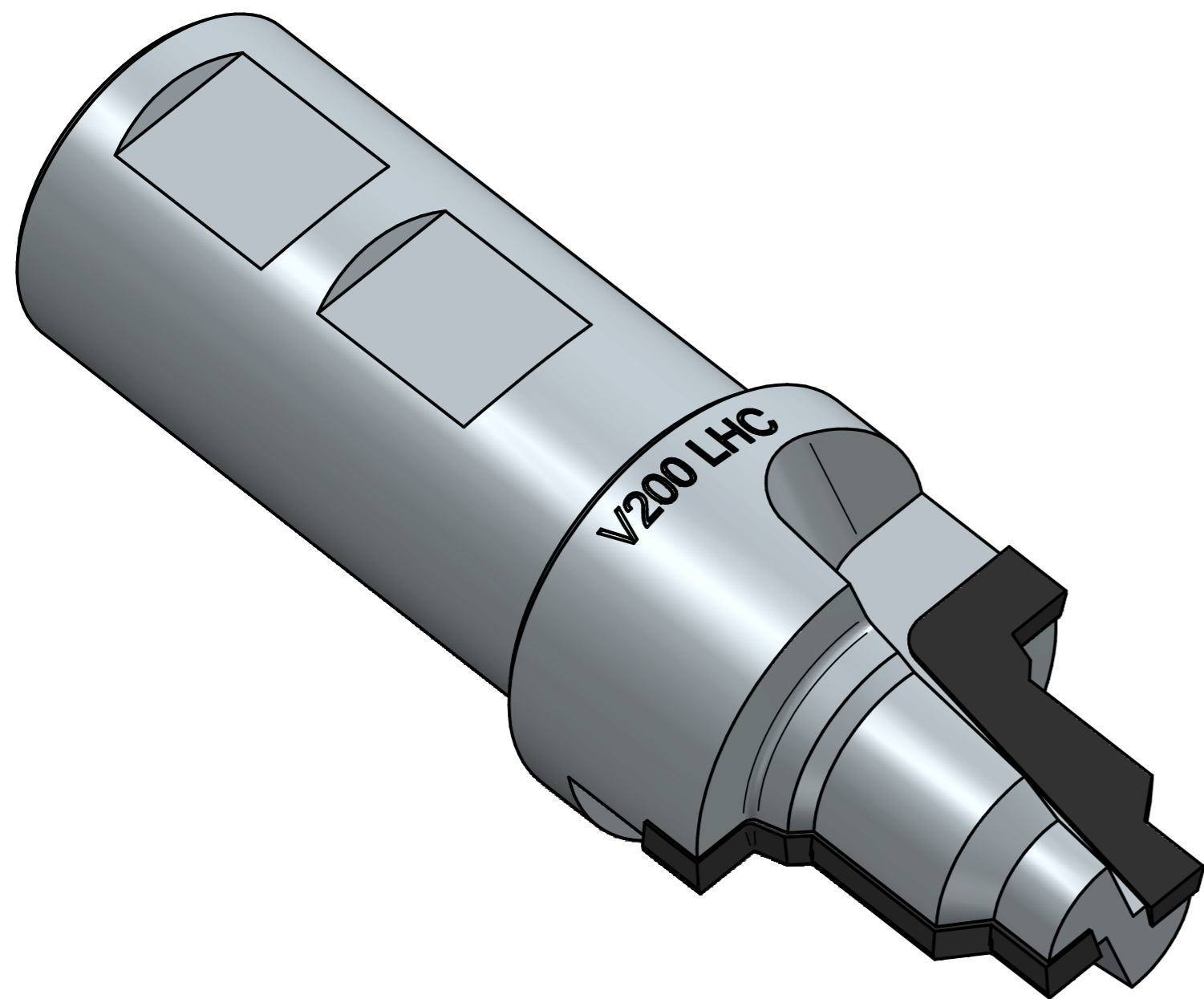

V200 Load Holding Check Bar  
CUTTING CAST IRON

DRAWN	NAME	DATE	<b>PREMAC</b>	
APPROVED	DG	10/31/17	TITLE	
MATERIAL			V200 Load Holding Check Bar	
TREATMENT			SIZE	DWG NO
UNLESS OTHERWISE SPECIFIED DIMENSIONS ARE IN MILLIMETERS			A4	V200 LHC
ANGLES $\pm 0,1^\circ$			REV	
1st ANGLE			FILE NAME: Load Holding Check Bar.dft	
2 PL $\pm 0,02$ 3 PL $\pm 0,005$			SCALE:	WEIGHT:
			SHEET 1 OF 3	