

REVISION HISTORY			
REV	DESCRIPTION	DATE	APPROVED

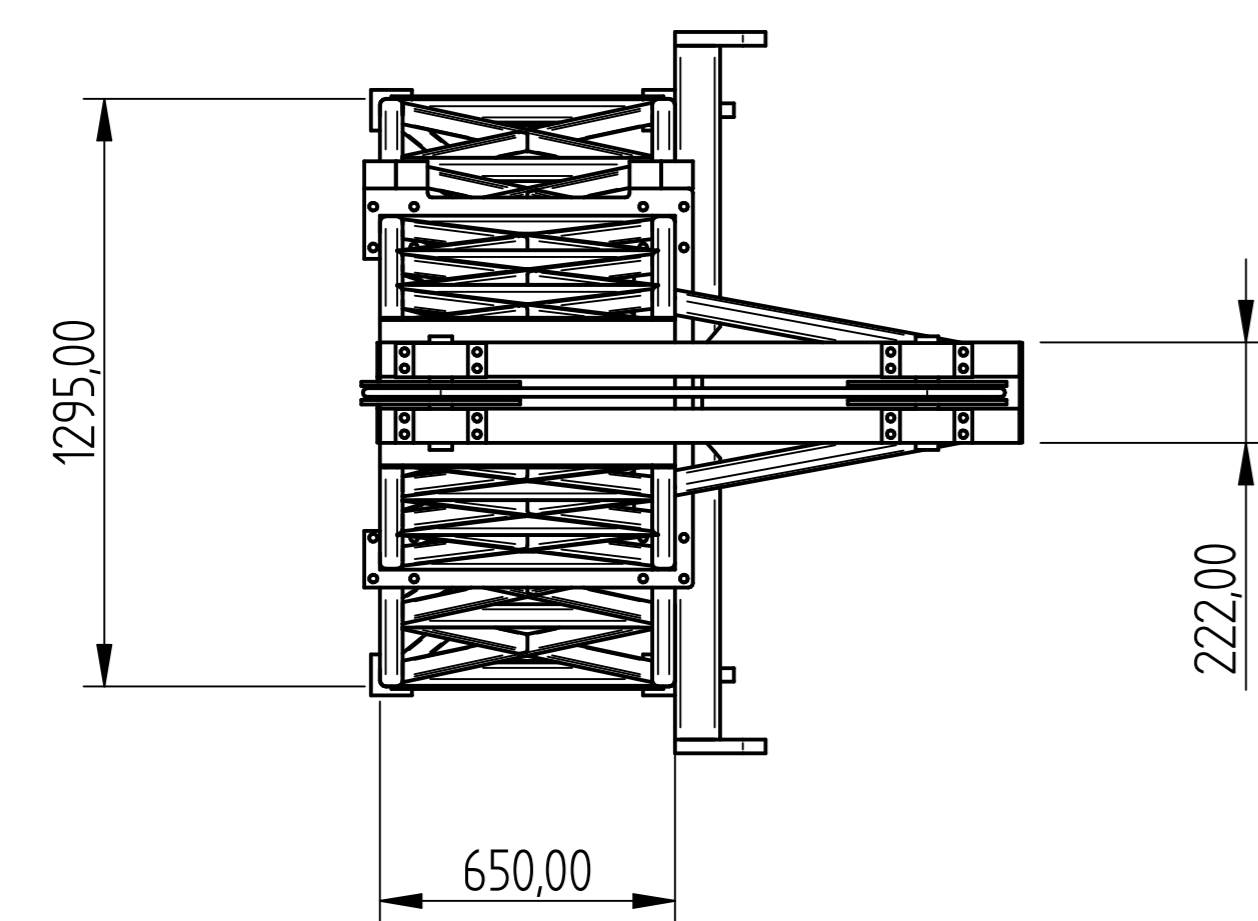
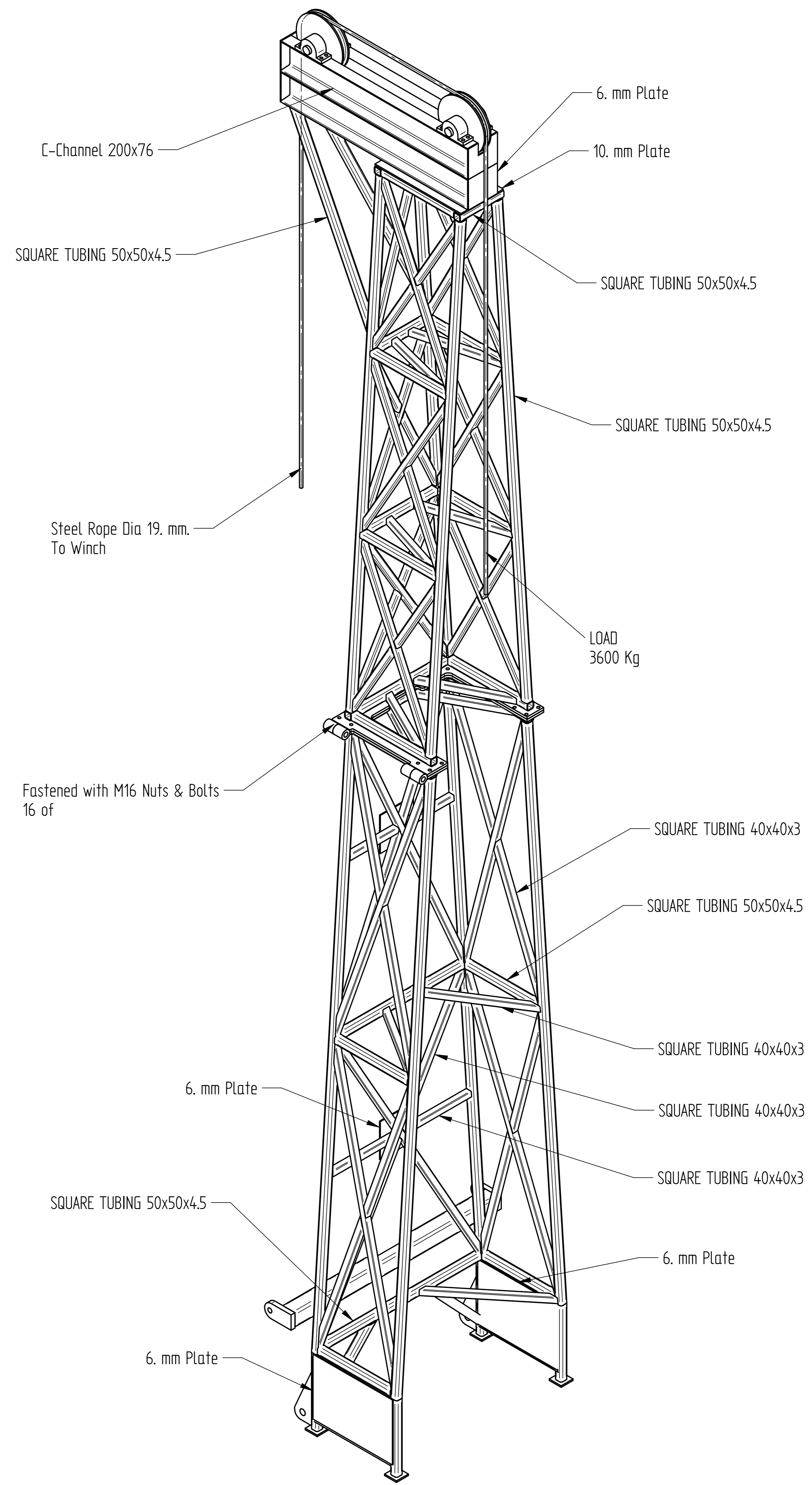
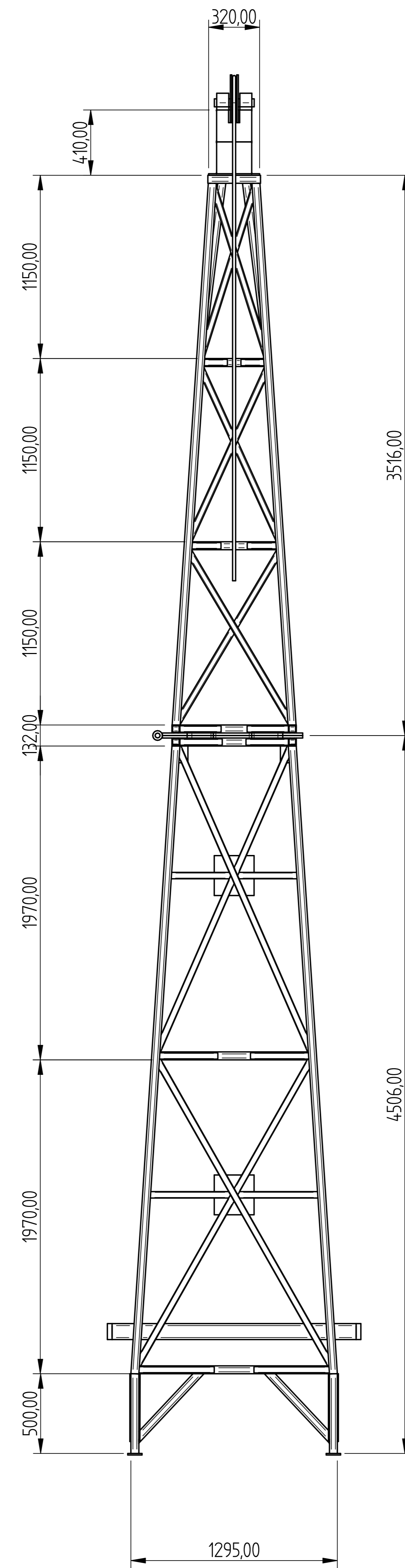
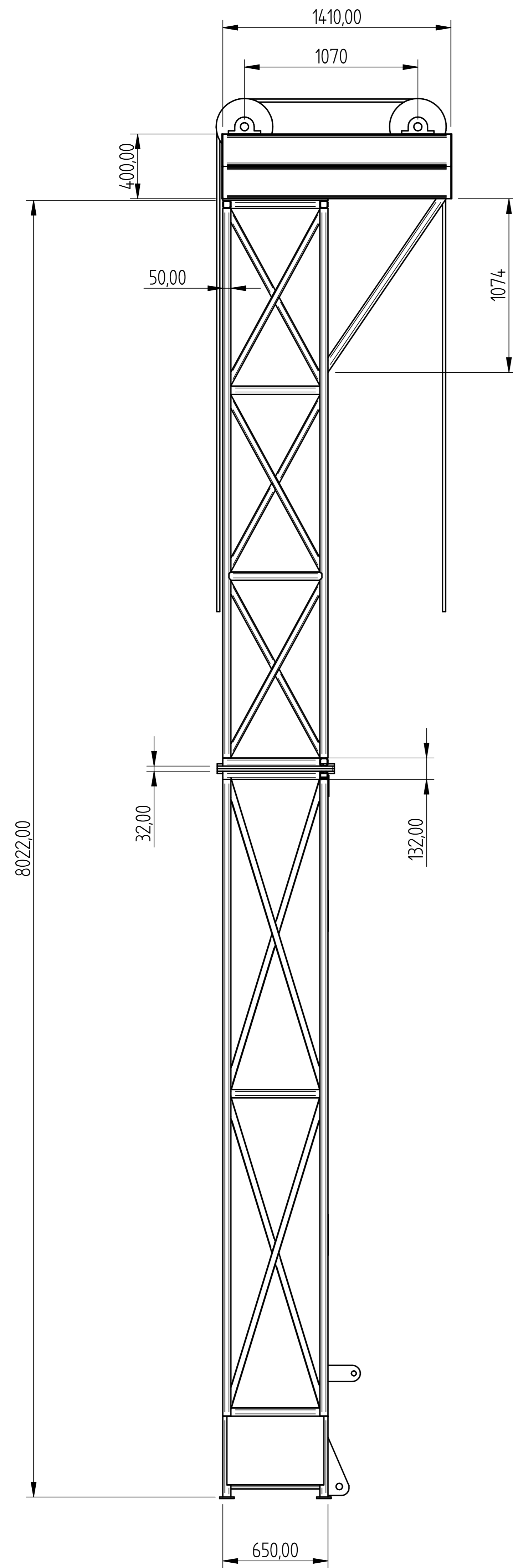

600 DERRICK
600-D-000

MATERIAL: SABS 1431 GRADE S355JR
ALL WELDING 10mm FILLET

NAME	DATE	EQUAL CHANCE TRADING 50	
DRAWN: Don	02/08/13	TITLE	600 DERRICK
APPROVED:		SIZE	A0
MATERIAL:		DWG NO	600-D-000
TREATMENT:		FILE NAME	600 Derrick.dft
UNLESS OTHERWISE SPECIFIED DIMENSIONS ARE IN MILLIMETERS		SCALE	WEIGHT
ANGLES ±0.1°		SHEET 1 OF 1	
2 PL ±0.02 3 PL ±0.005			