

REVISION HISTORY			
REV	DESCRIPTION	DATE	APPROVED

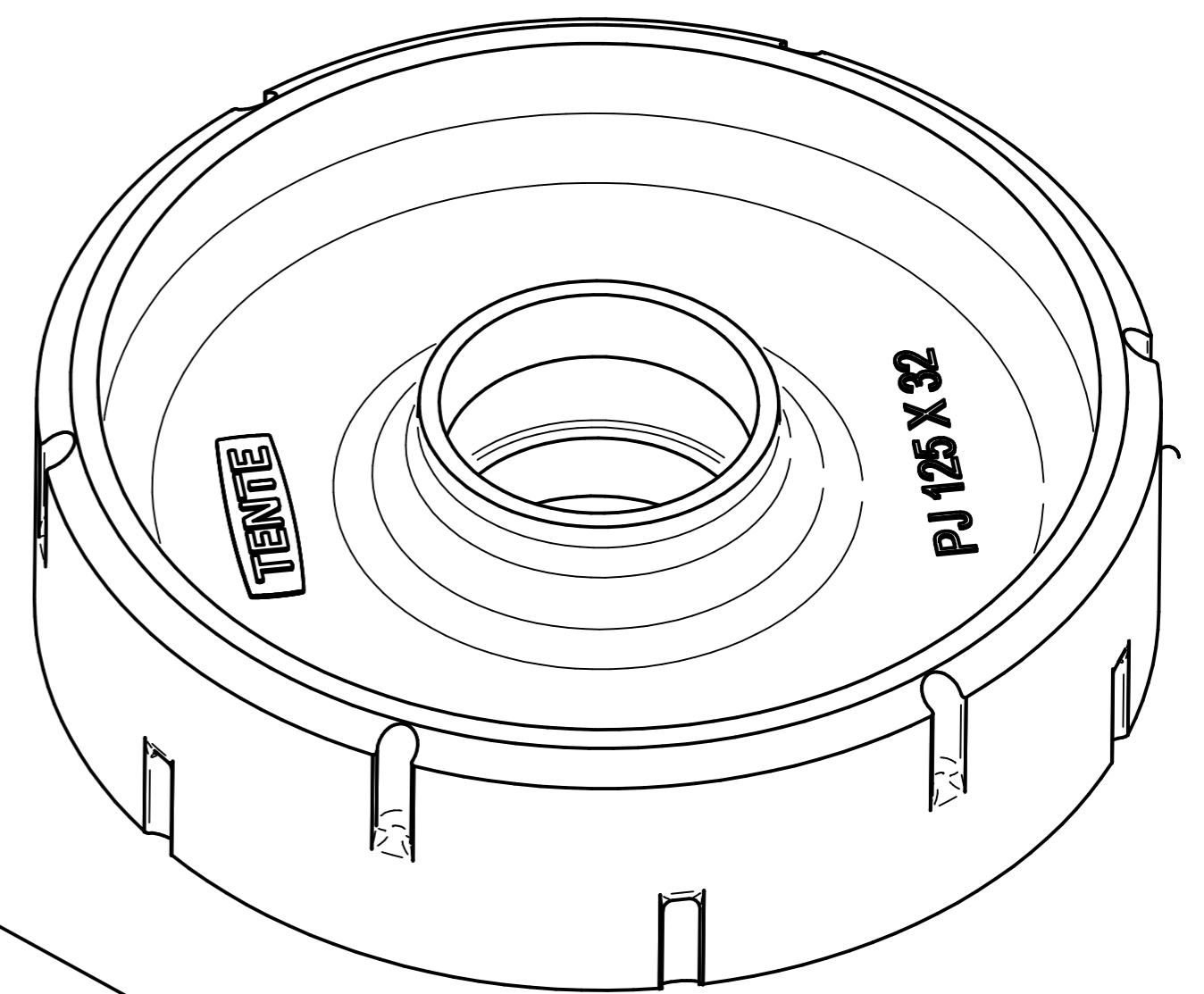

DRAWN	NAME	DATE	PREMAC		
APPROVED	Dan	05/22/18			
MATERIAL			TITLE		
TREATMENT			REV		
UNLESS OTHERWISE SPECIFIED DIMENSIONS ARE IN MILLIMETERS ANGLES ±0.1°			SIZE A4	DWG NO	REV
1st ANGLE 2 PL ±0.02 3 PL ±0.005			FILE NAME: PJP125X32 WC-ND Wheel Centre Mould.dff		
			SCALE:	WEIGHT:	SHEET 1 OF 6

REVISION HISTORY			
REV	DESCRIPTION	DATE	APPROVED

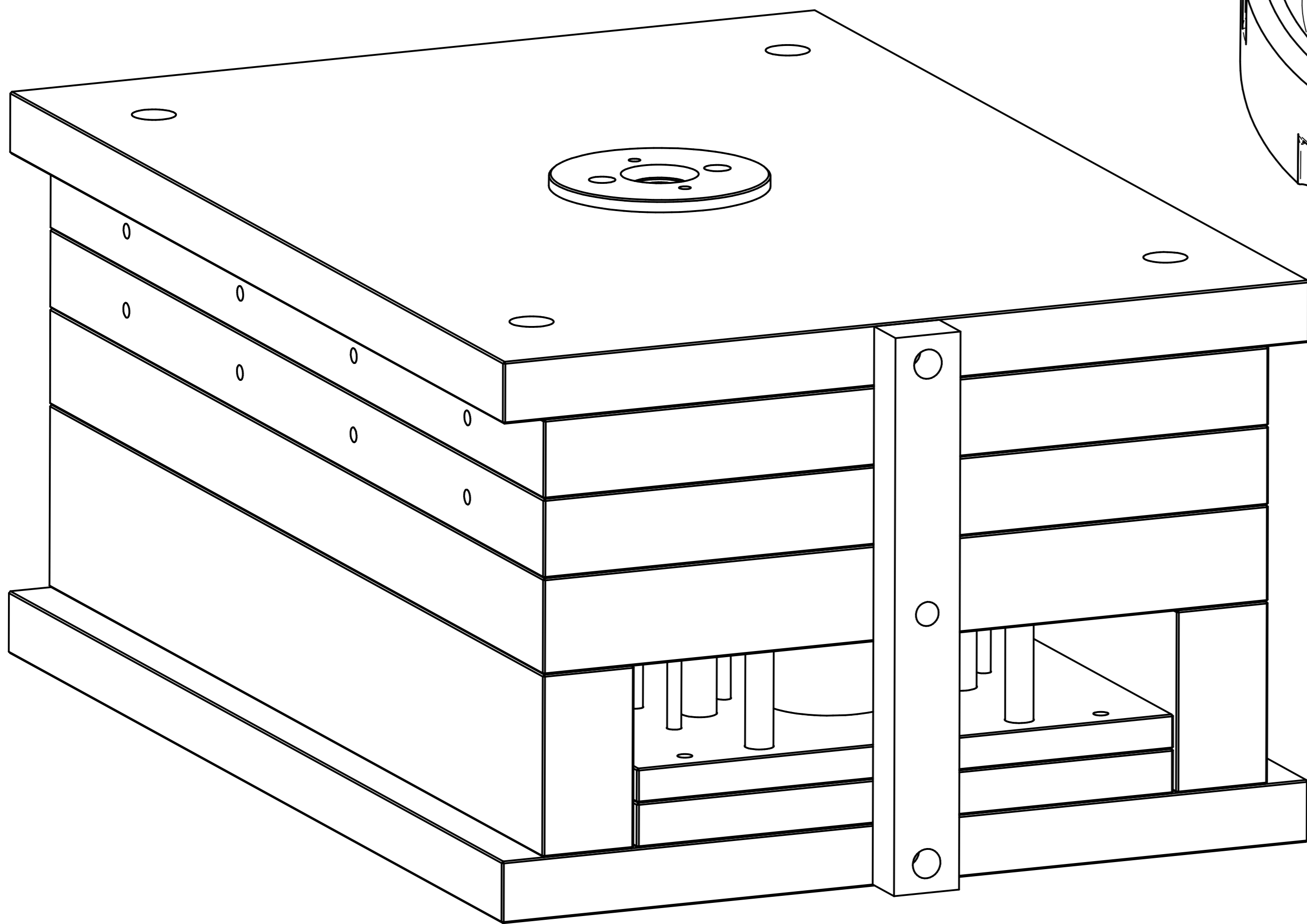
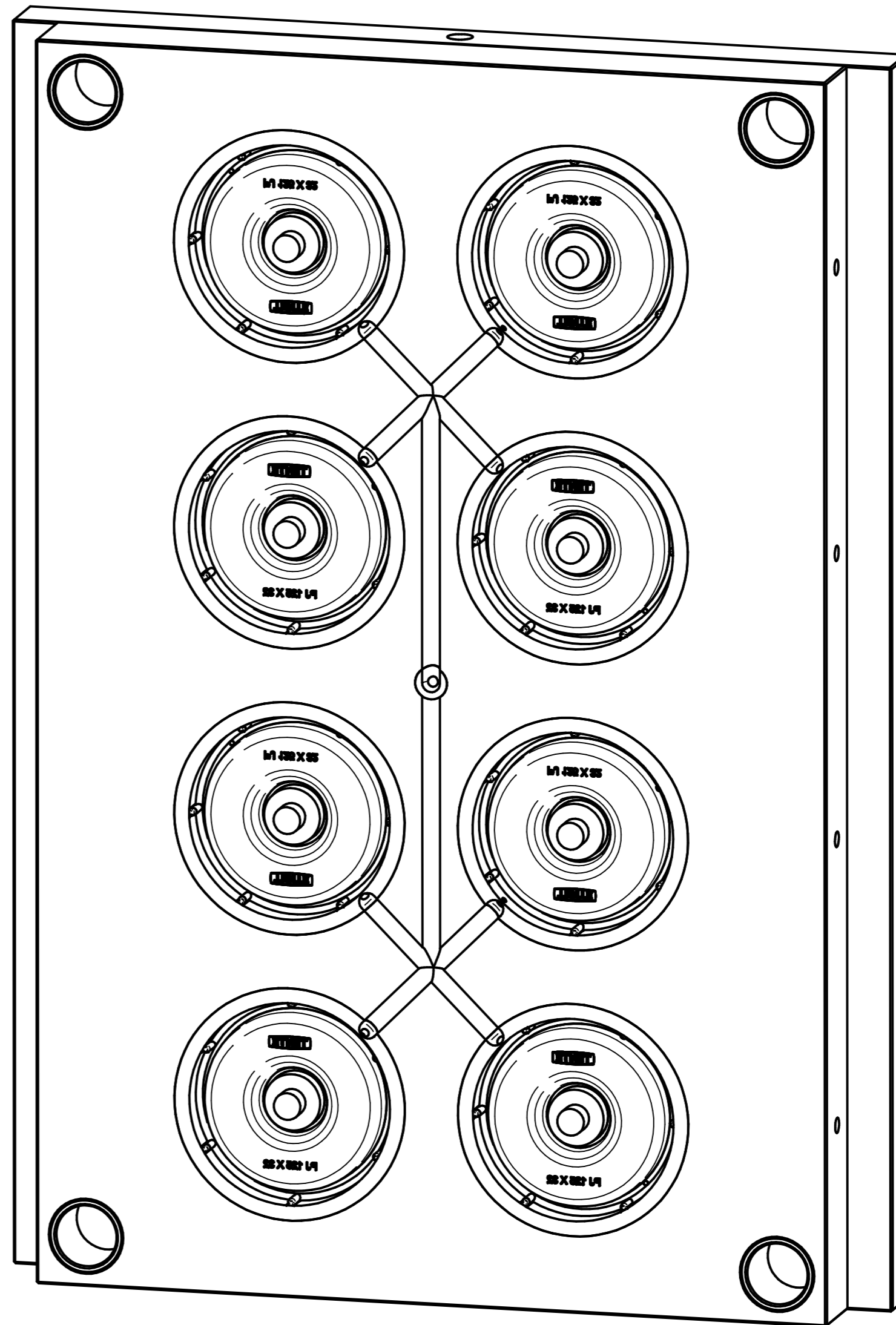
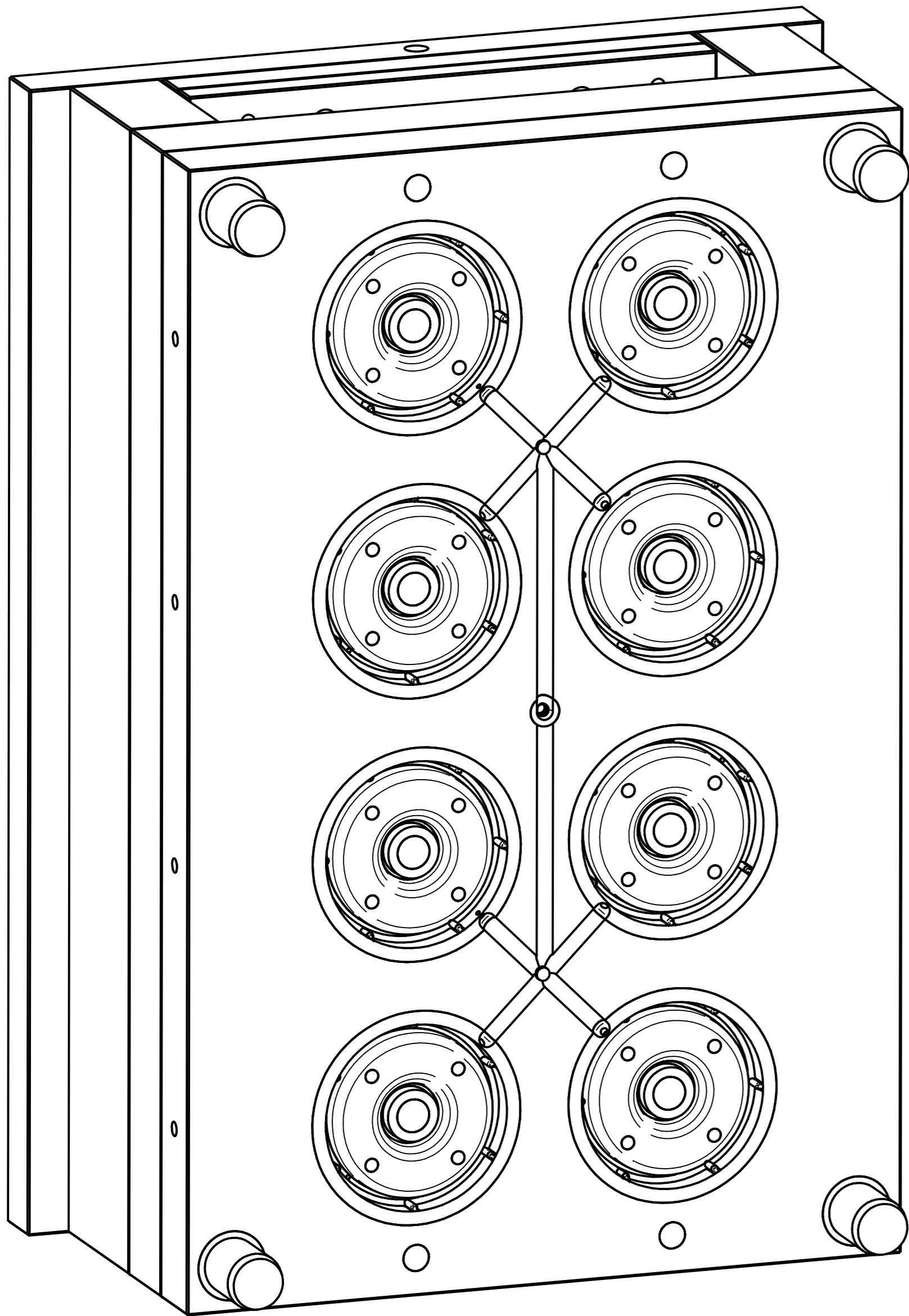

DRAWN	NAME	DATE	PREMAC		
APPROVED	Dan	05/22/18			
MATERIAL					
TREATMENT					
UNLESS OTHERWISE SPECIFIED DIMENSIONS ARE IN MILLIMETERS			SIZE	DWG NO	REV
1 ST ANGLE ANGLES ±0.1°			A4		
2 PL ±0.02 3 PL ±0.005			FILE NAME: PJP125X32 WC-ND Wheel Centre Mould.dff		
SCALE:		WEIGHT:		SHEET 2 OF 6	

REVISION HISTORY			
REV	DESCRIPTION	DATE	APPROVED

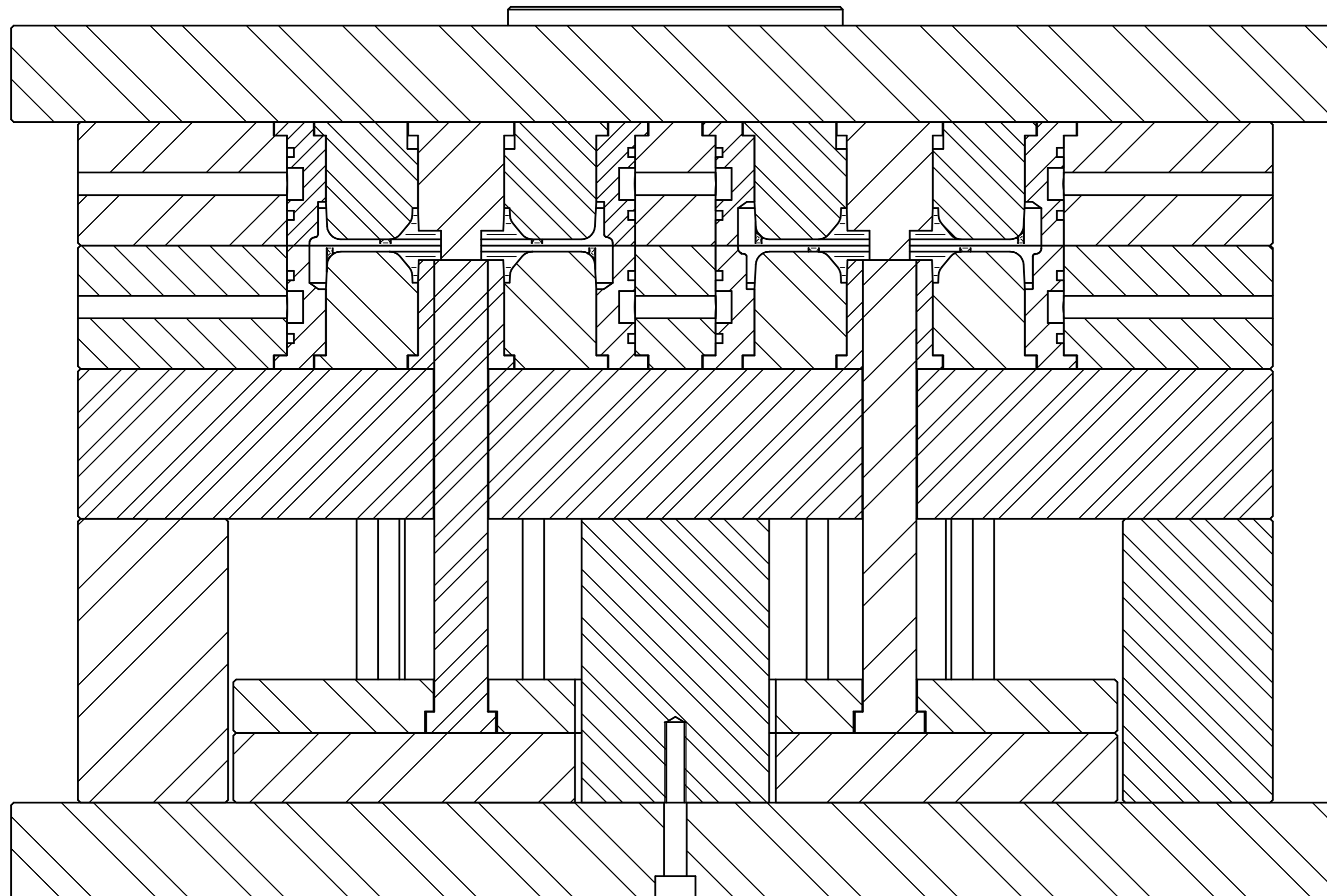

	NAME	DATE	PREMAC	
DRAWN	Dan	05/22/18		
APPROVED				
MATERIAL				
TREATMENT			TITLE	
UNLESS OTHERWISE SPECIFIED DIMENSIONS ARE IN MILLIMETERS			SIZE A4	DWG NO
1 ST ANGLE ANGLES ±0.1°			FILE NAME: PJP125X32 WC-ND Wheel Centre Mould.dff	REV
2 PL ±0.02 3 PL ±0.005			SCALE:	WEIGHT:
			SHEET 3 OF 6	

REVISION HISTORY			
REV	DESCRIPTION	DATE	APPROVED

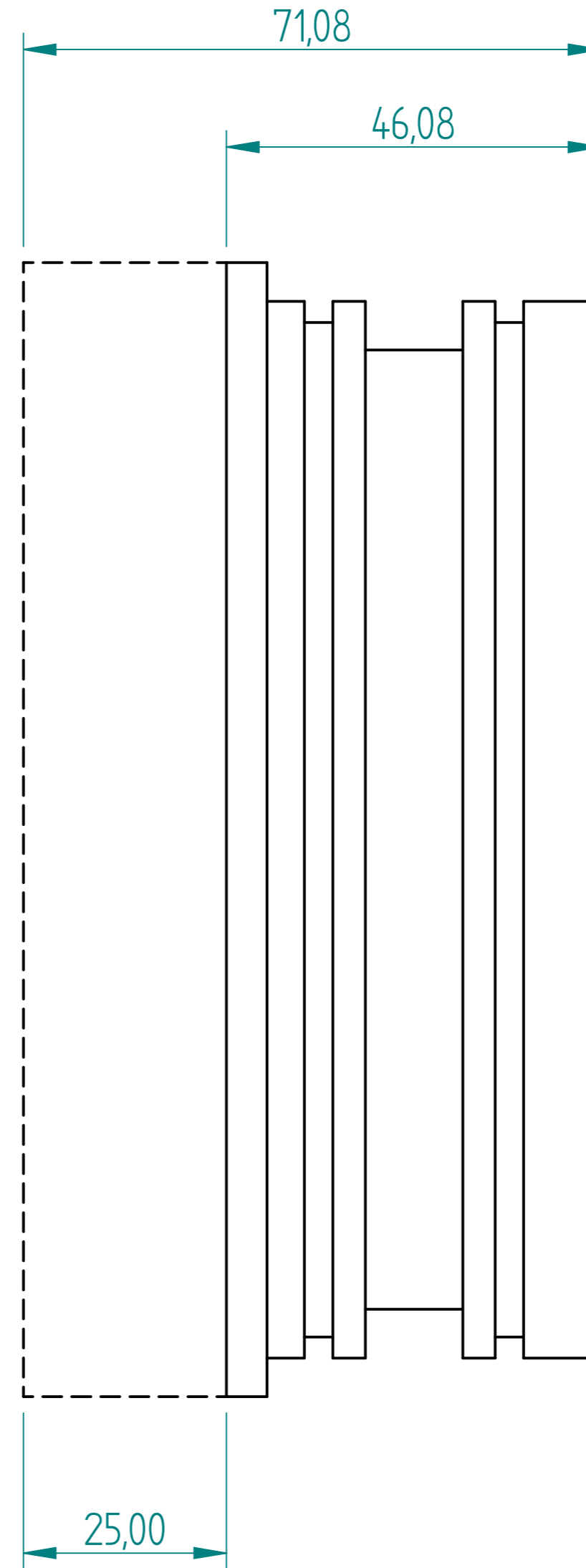
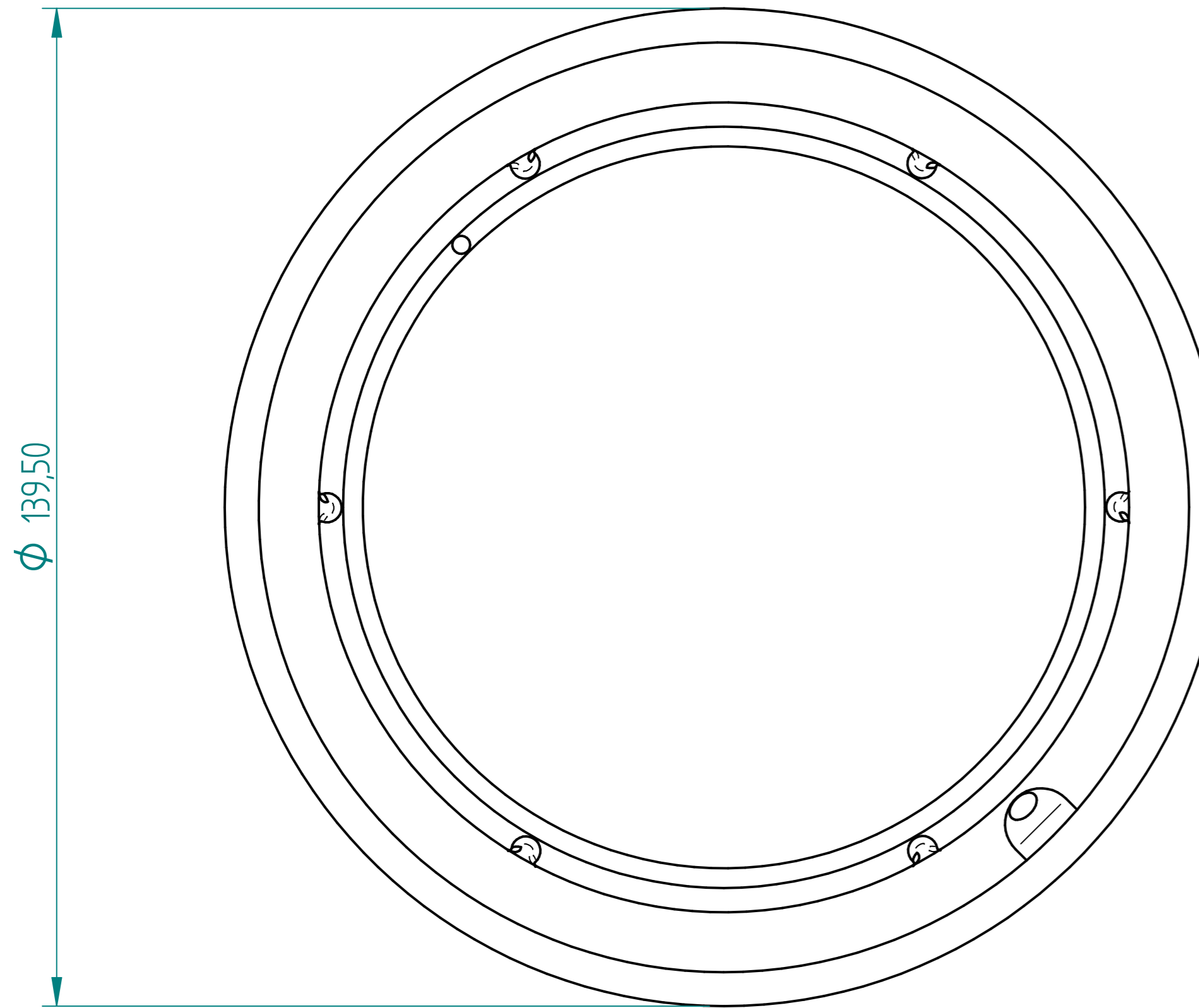

FH and MH WC OUTER INSERT
16 OFF

	NAME	DATE	PREMAC	
DRAWN	Dan	05/22/18		
APPROVED			TITLE	
MATERIAL				
TREATMENT				
UNLESS OTHERWISE SPECIFIED DIMENSIONS ARE IN MILLIMETERS			SIZE A4	DWG NO
1 ST ANGLE ANGLES $\pm 0,1^\circ$				REV
2 PL $\pm 0,02$ 3 PL $\pm 0,005$			FILE NAME: PJP125X32 WC-ND Wheel Centre Mould.dff	
SCALE:		WEIGHT:	SHEET 4 OF 6	

REVISION HISTORY			
REV	DESCRIPTION	DATE	APPROVED

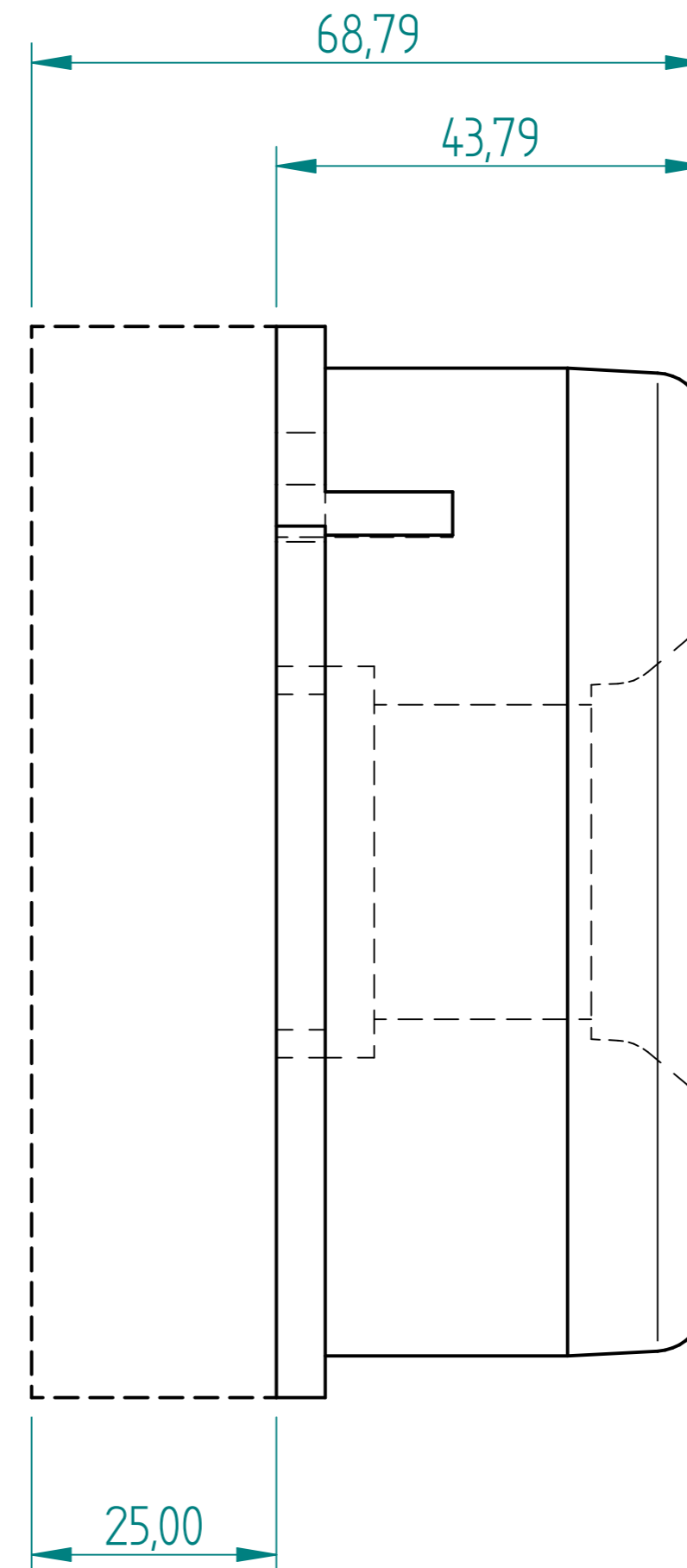
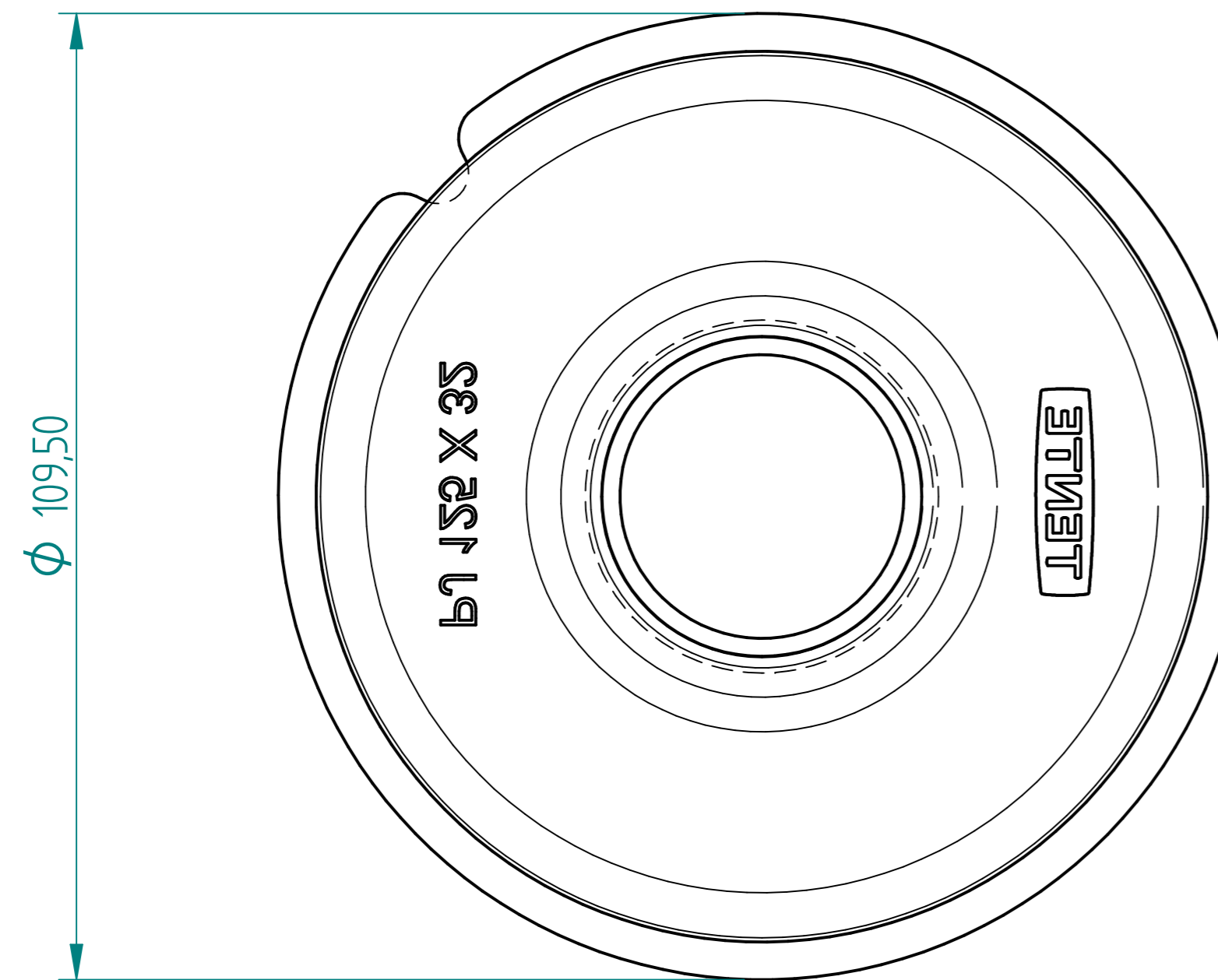

FH and MH WC CENTRE INSERT
16 OFF

	NAME	DATE	PREMAC	
DRAWN	Dan	05/22/18		
APPROVED			TITLE	
MATERIAL				
TREATMENT			SIZE A4 DWG NO FILE NAME: PJP125X32 WC-ND Wheel Centre Mould.dff	
UNLESS OTHERWISE SPECIFIED DIMENSIONS ARE IN MILLIMETERS ANGLES $\pm 0.1^\circ$ <small>1st ANGLE</small>				
2 PL ± 0.02	3 PL ± 0.005		SHEET 5 OF 6	

REVISION HISTORY			
REV	DESCRIPTION	DATE	APPROVED

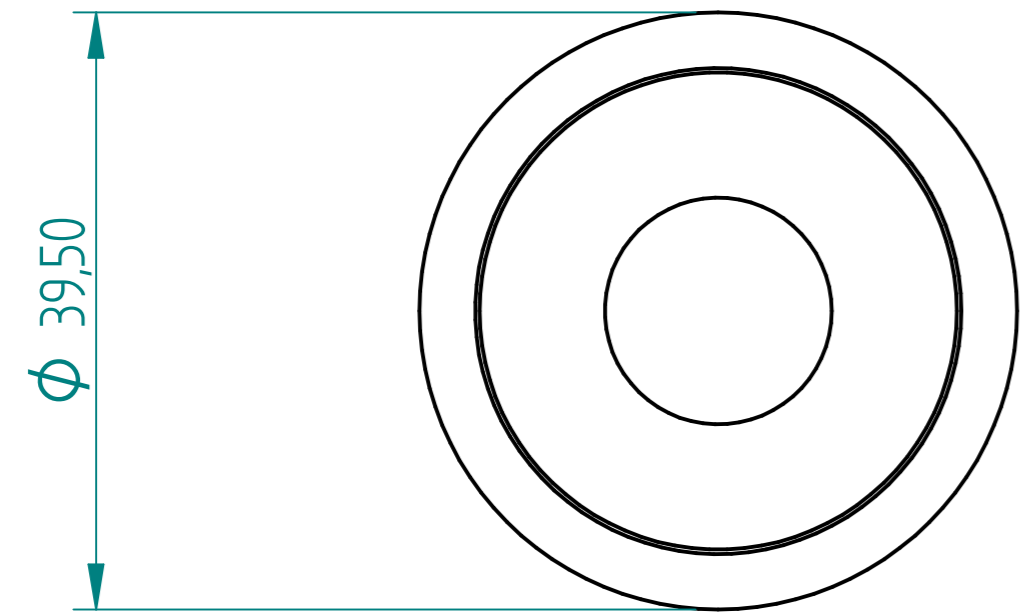

FH WC INNER INSERT
8 OFF

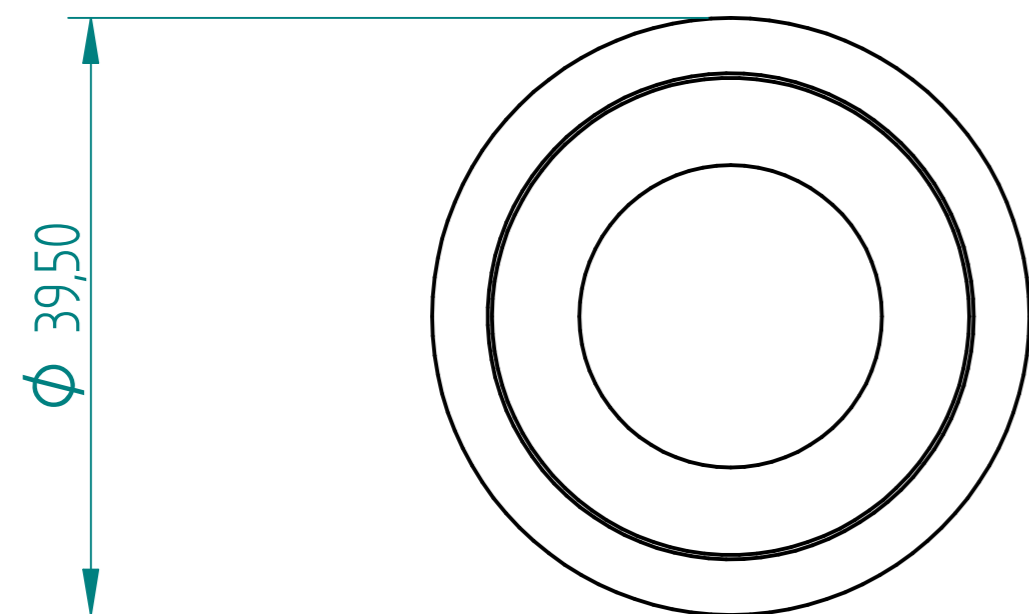
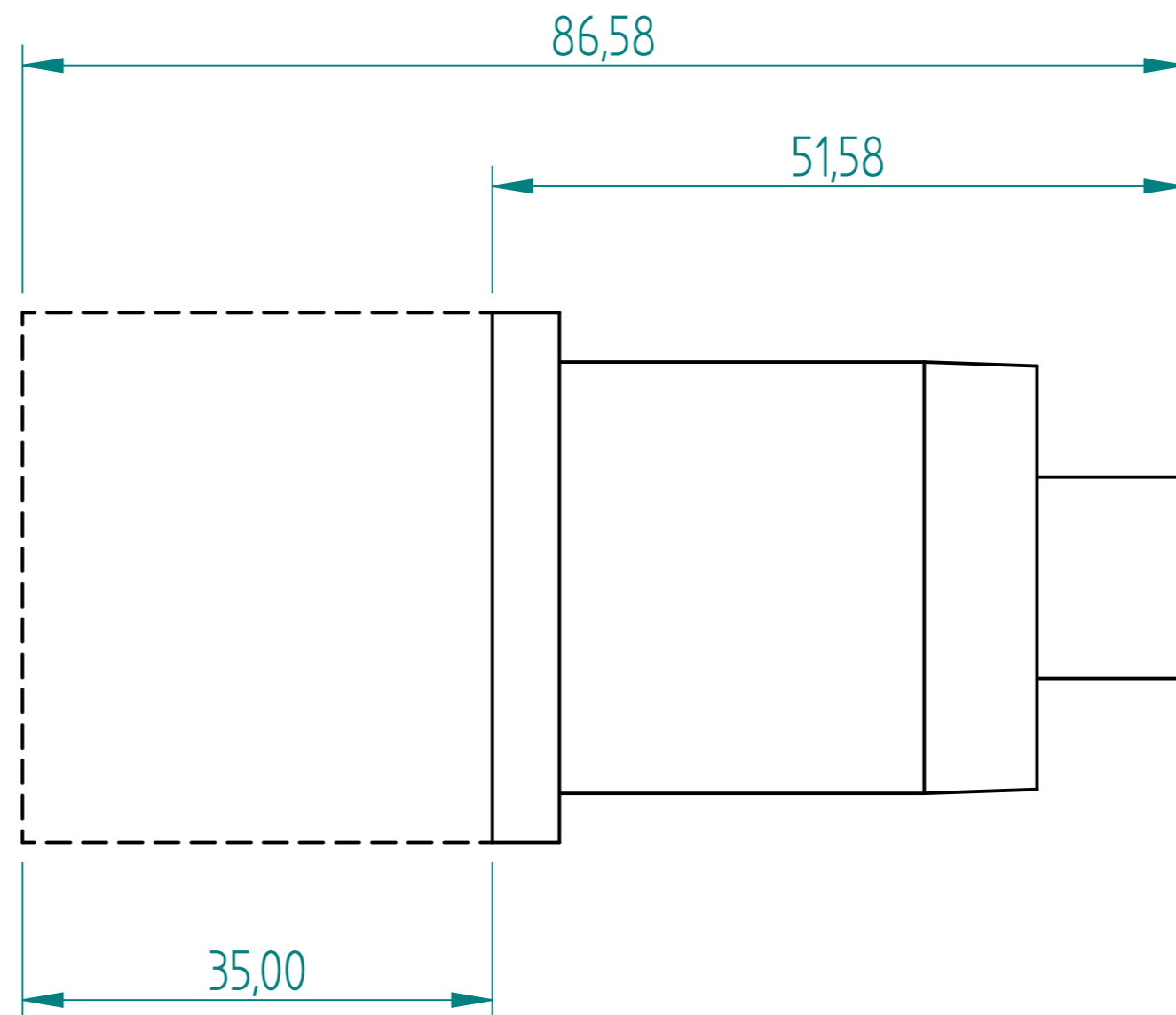

MH WC INNER INSERT
8 OFF

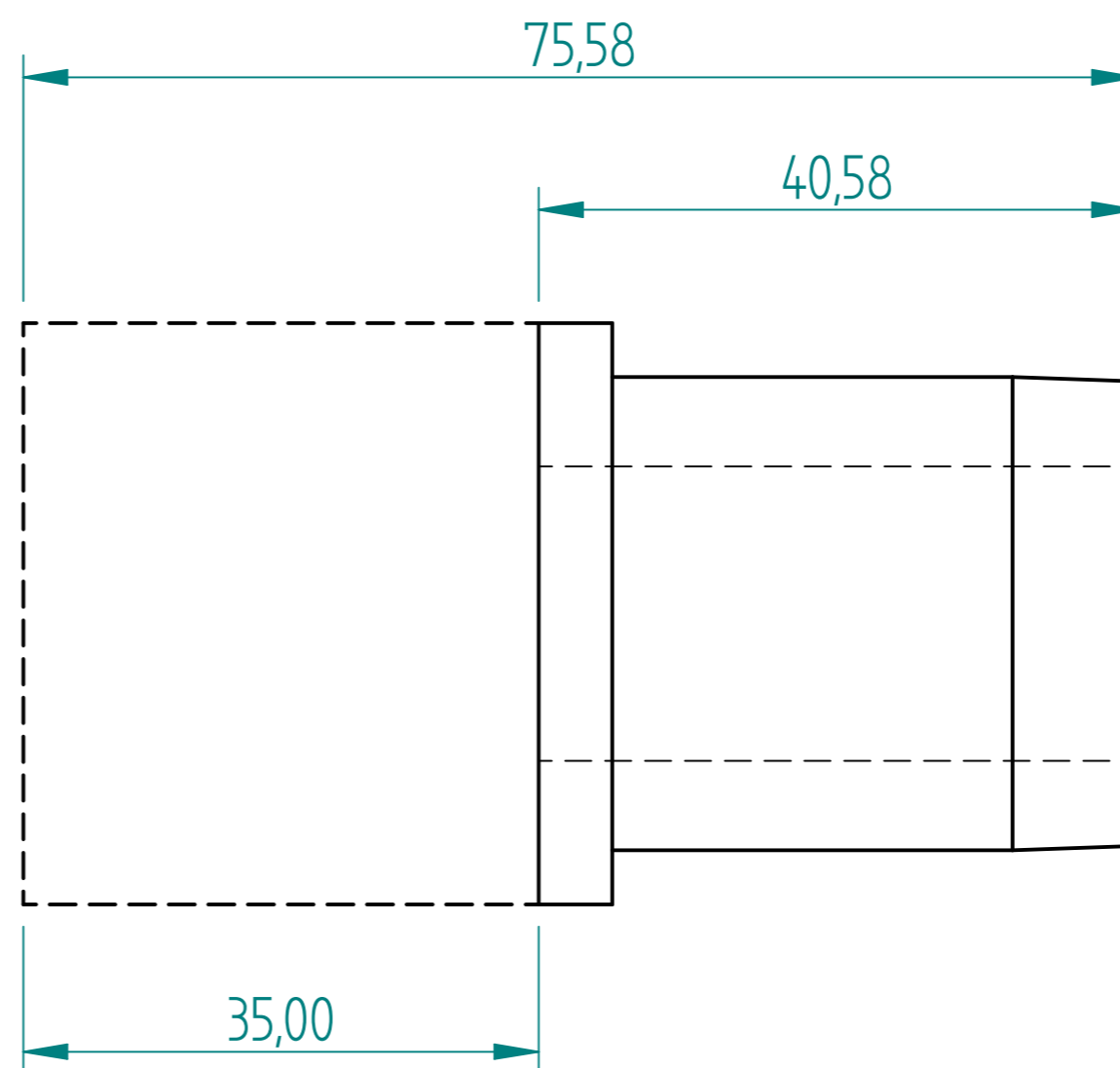

	NAME	DATE	PREMAC	
DRAWN	Dan	05/22/18		
APPROVED				
MATERIAL				
TREATMENT			TITLE	
UNLESS OTHERWISE SPECIFIED DIMENSIONS ARE IN MILLIMETERS			SIZE A4	DWG NO
1 ST ANGLE ANGLES ±0.1°			FILE NAME: PJP125X32 WC-ND Wheel Centre Mould.dff	REV
2 PL ±0.02 3 PL ±0.005			SCALE:	WEIGHT:
			SHEET 6 OF 6	