

| REVISION HISTORY |             |      |          |
|------------------|-------------|------|----------|
| REV              | DESCRIPTION | DATE | APPROVED |
|                  |             |      |          |

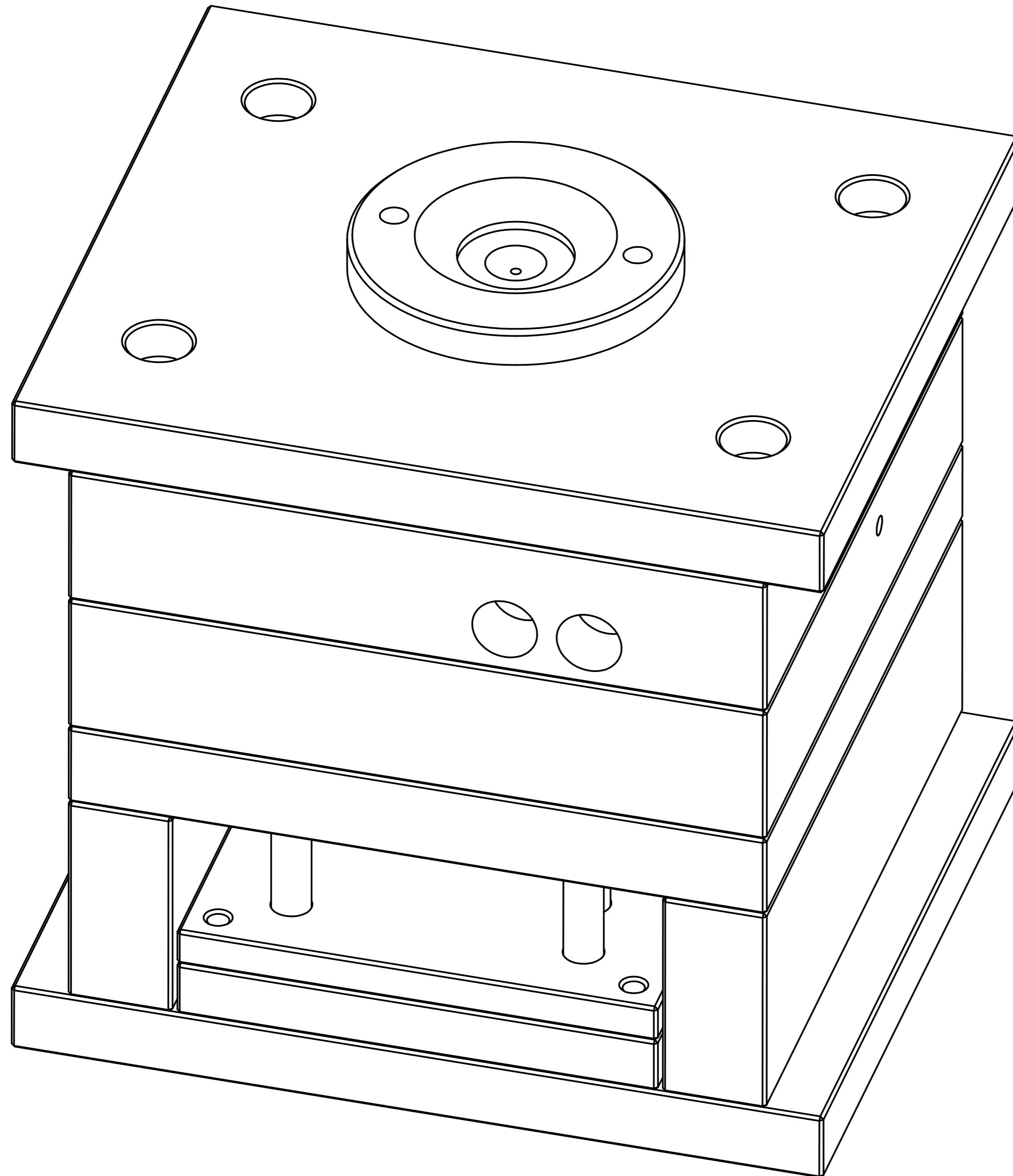

|   |      |          |                             |                      |
|---|------|----------|-----------------------------|----------------------|
|   | NAME | DATE     | <b>PREMAC</b>               |                      |
| DRAWN   | Dan  | 09/03/21 |                             |                      |
| APPROVED  |      |          | TITLE                       |                      |
| MATERIAL  |      |          |                             |                      |
| TREATMENT   |      |          |                             |                      |
| UNLESS OTHERWISE SPECIFIED<br>DIMENSIONS ARE IN MILLIMETERS |      |          | SIZE<br>A4                  | DWG NO               |
| 1st ANGLE<br>ANGLES ±0.1°                                   |      |          | FILE NAME: Family Mould.dft |                      |
| 2 PL ±0.02 3 PL ±0.005                                      |      |          | SCALE:                      | WEIGHT: SHEET 1 OF 5 |

| REVISION HISTORY |             |      |          |
|------------------|-------------|------|----------|
| REV              | DESCRIPTION | DATE | APPROVED |
|                  |             |      |          |

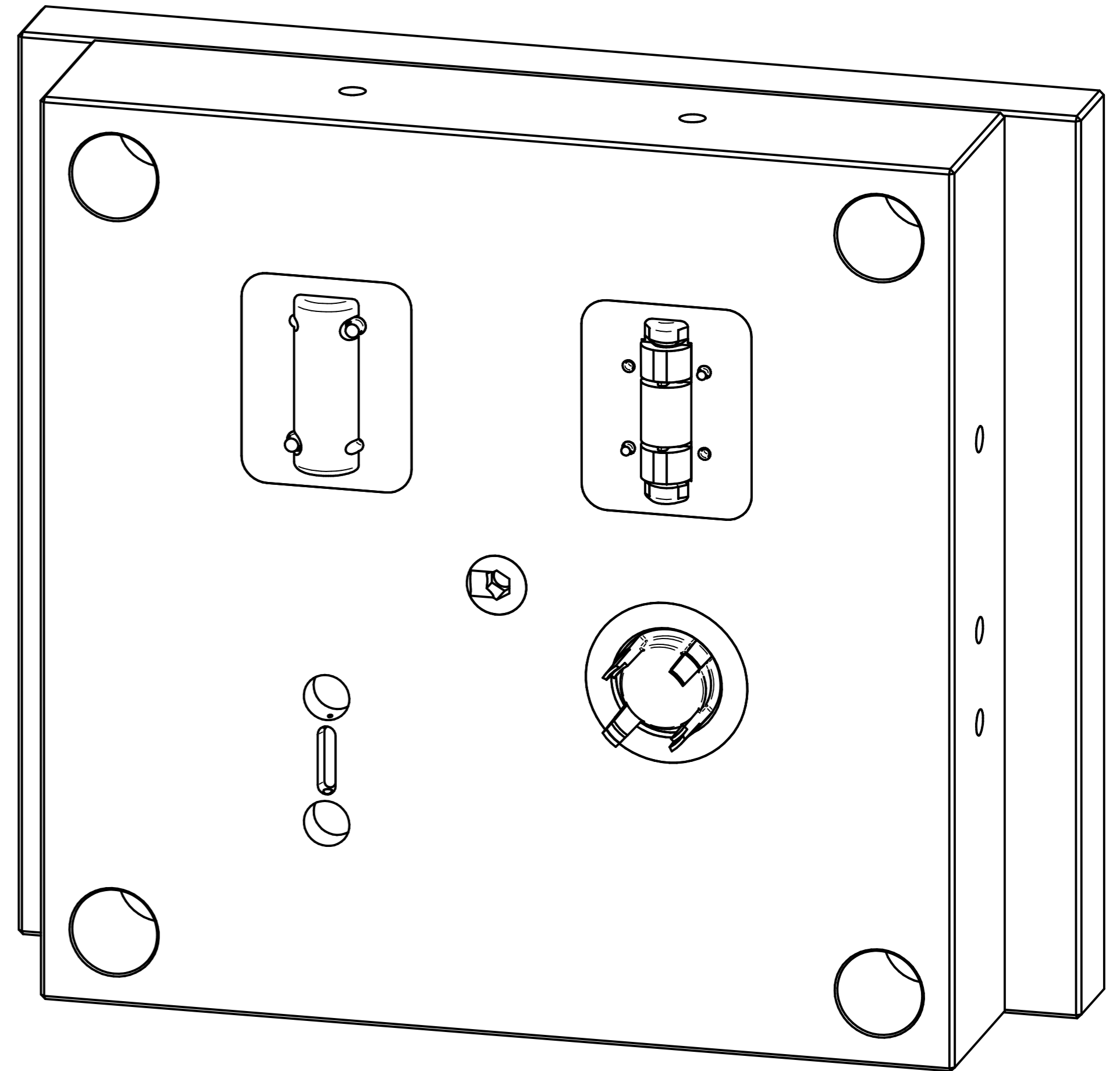
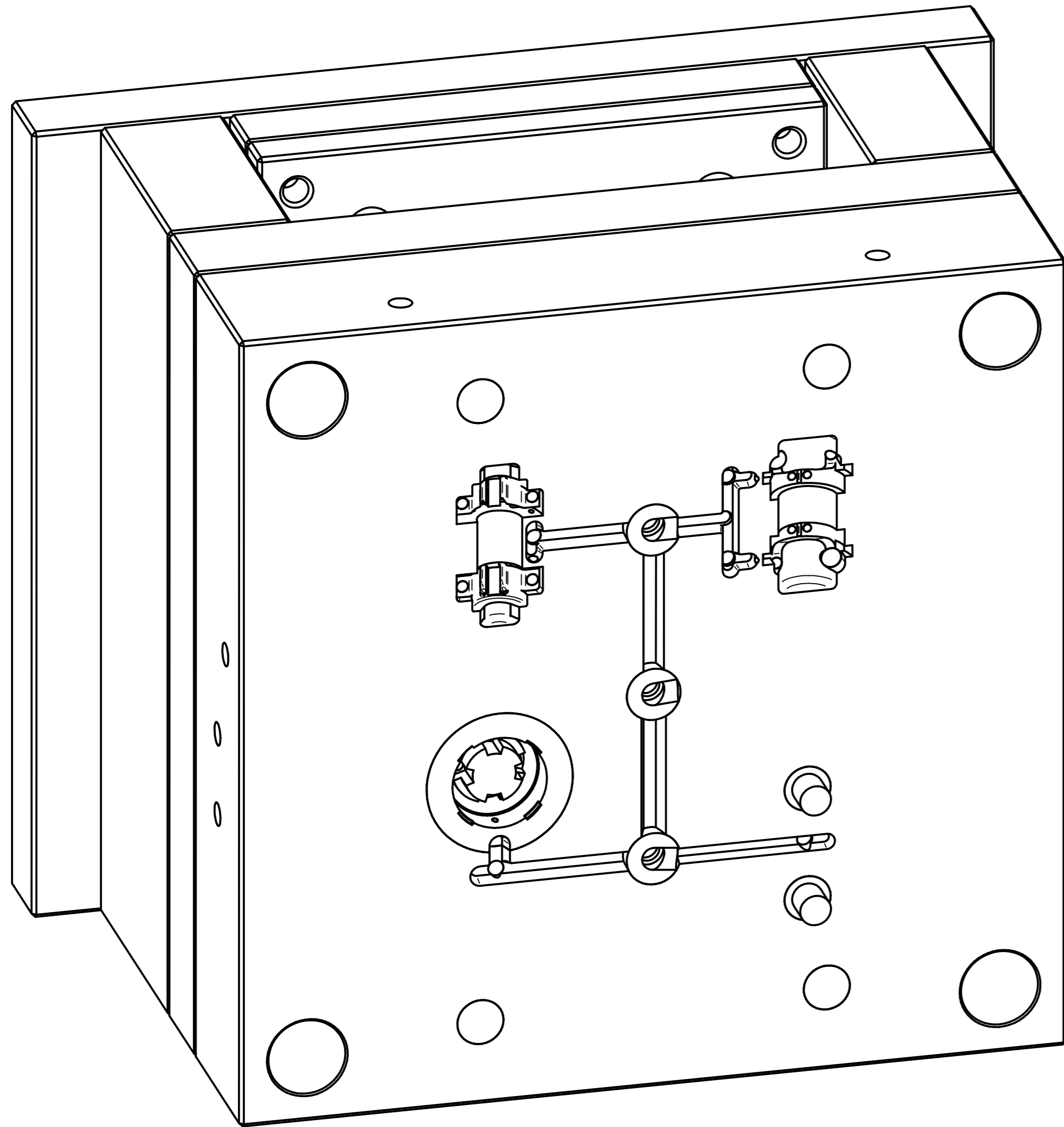

|   |      |          |                             |         |              |
|---|------|----------|-----------------------------|---------|--------------|
|   | NAME | DATE     | <b>PREMAC</b>               |         |              |
| DRAWN   | Dan  | 09/03/21 |                             |         |              |
| APPROVED  |      |          |                             |         |              |
| MATERIAL  |      |          |                             |         |              |
| TREATMENT   |      |          | TITLE                       |         |              |
| UNLESS OTHERWISE SPECIFIED<br>DIMENSIONS ARE IN MILLIMETERS<br>ANGLES ±0.1° |      |          | SIZE<br>A4                  | DWG NO  | REV          |
| 1st ANGLE<br>2 PL ±0.02 3 PL ±0.005   |      |          | FILE NAME: Family Mould.dft |         |              |
|   |      |          | SCALE:                      | WEIGHT: | SHEET 2 OF 5 |

| REVISION HISTORY |             |      |          |
|------------------|-------------|------|----------|
| REV              | DESCRIPTION | DATE | APPROVED |
|                  |             |      |          |

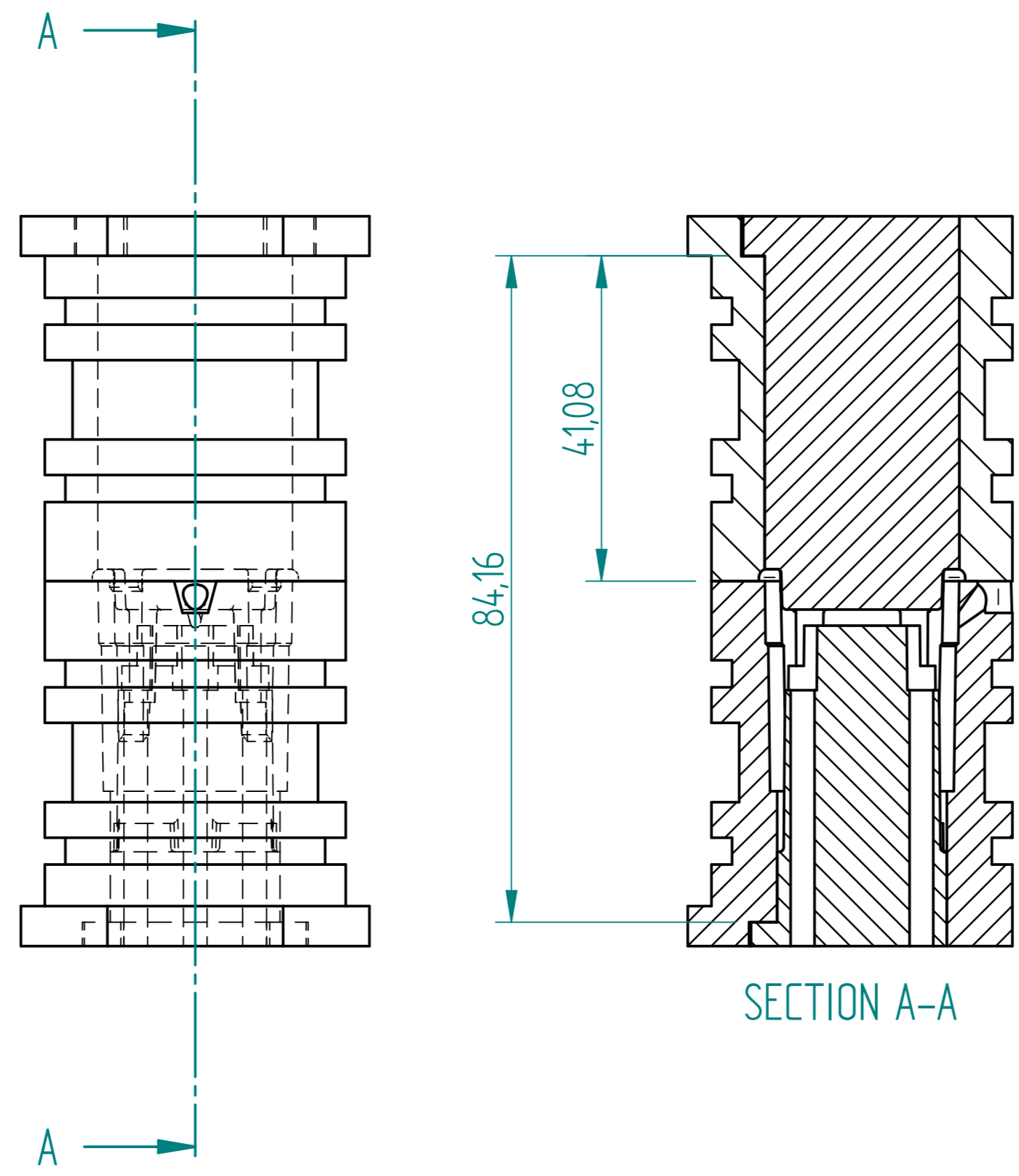

SECTION A-A

|   |      |          |                             |         |              |
|---|------|----------|-----------------------------|---------|--------------|
|   | NAME | DATE     | <b>PREMAC</b>               |         |              |
| DRAWN   | Dan  | 09/03/21 |                             |         |              |
| APPROVED  |      |          | TITLE                       |         |              |
| MATERIAL  |      |          |                             |         |              |
| TREATMENT   |      |          | SIZE                        | DWG NO  | REV          |
| UNLESS OTHERWISE SPECIFIED<br>DIMENSIONS ARE IN MILLIMETERS |      |          | A4                          |         |              |
| 1 <sup>ST</sup> ANGLE<br>ANGLES ±0.1°                       |      |          | FILE NAME: Family Mould.dft |         |              |
| 2 PL ±0.02 3 PL ±0.005                                      |      |          | SCALE:                      | WEIGHT: | SHEET 3 OF 5 |



| REVISION HISTORY |             |      |          |
|------------------|-------------|------|----------|
| REV              | DESCRIPTION | DATE | APPROVED |
|                  |             |      |          |

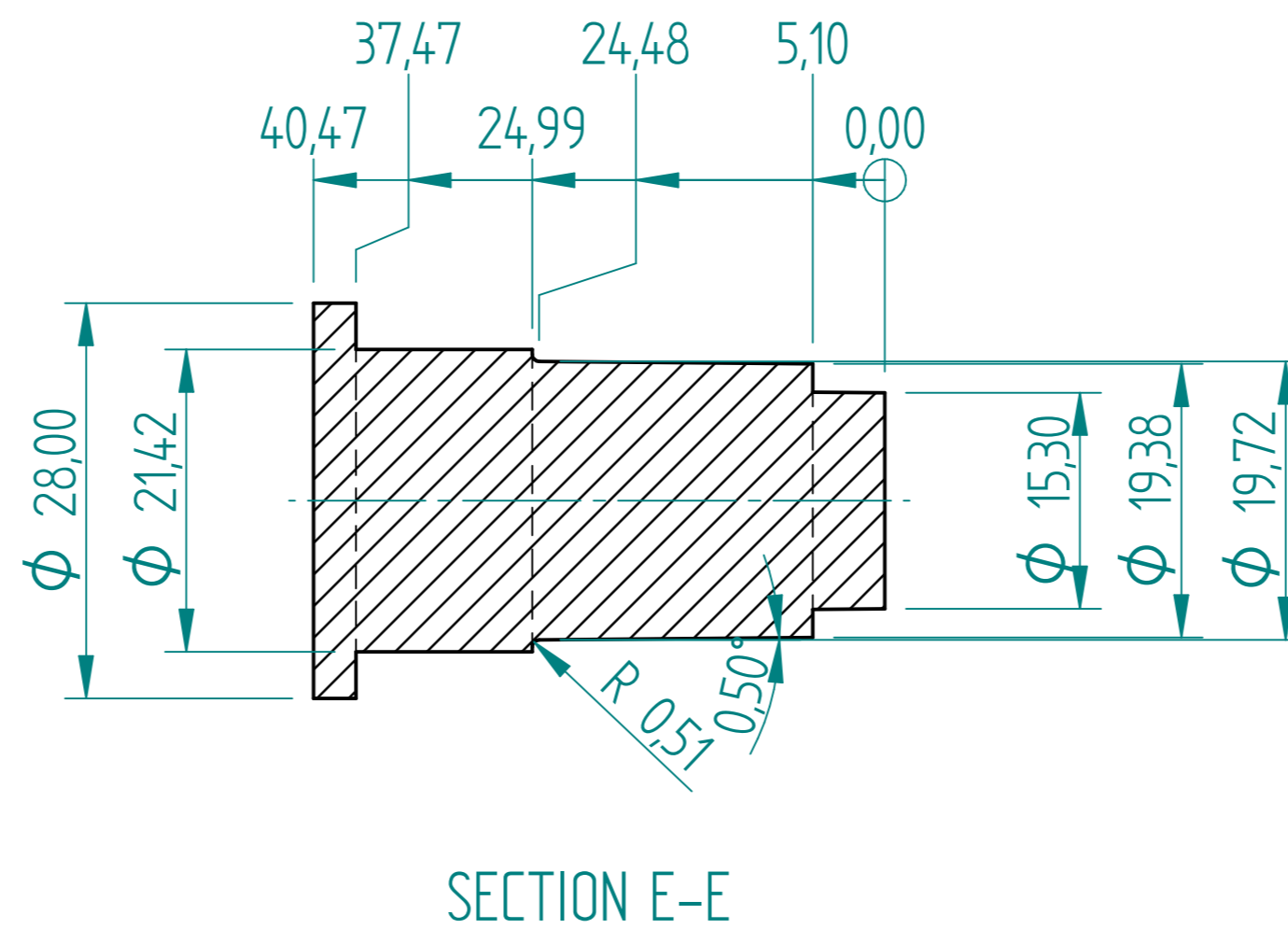
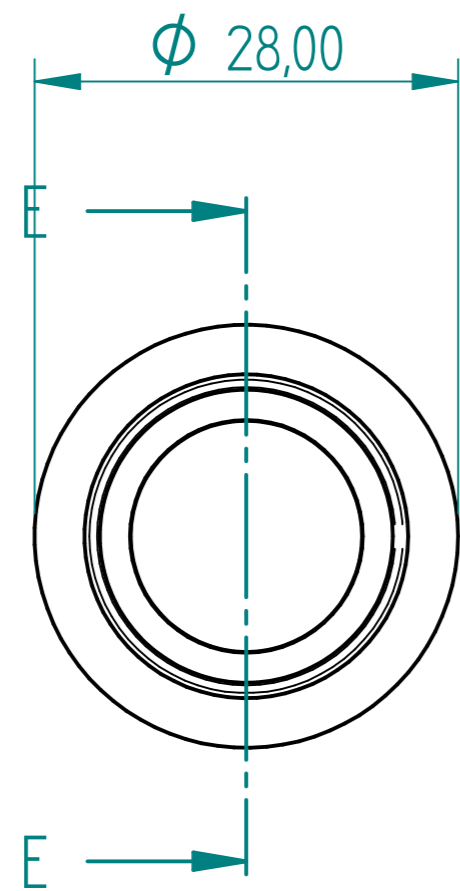
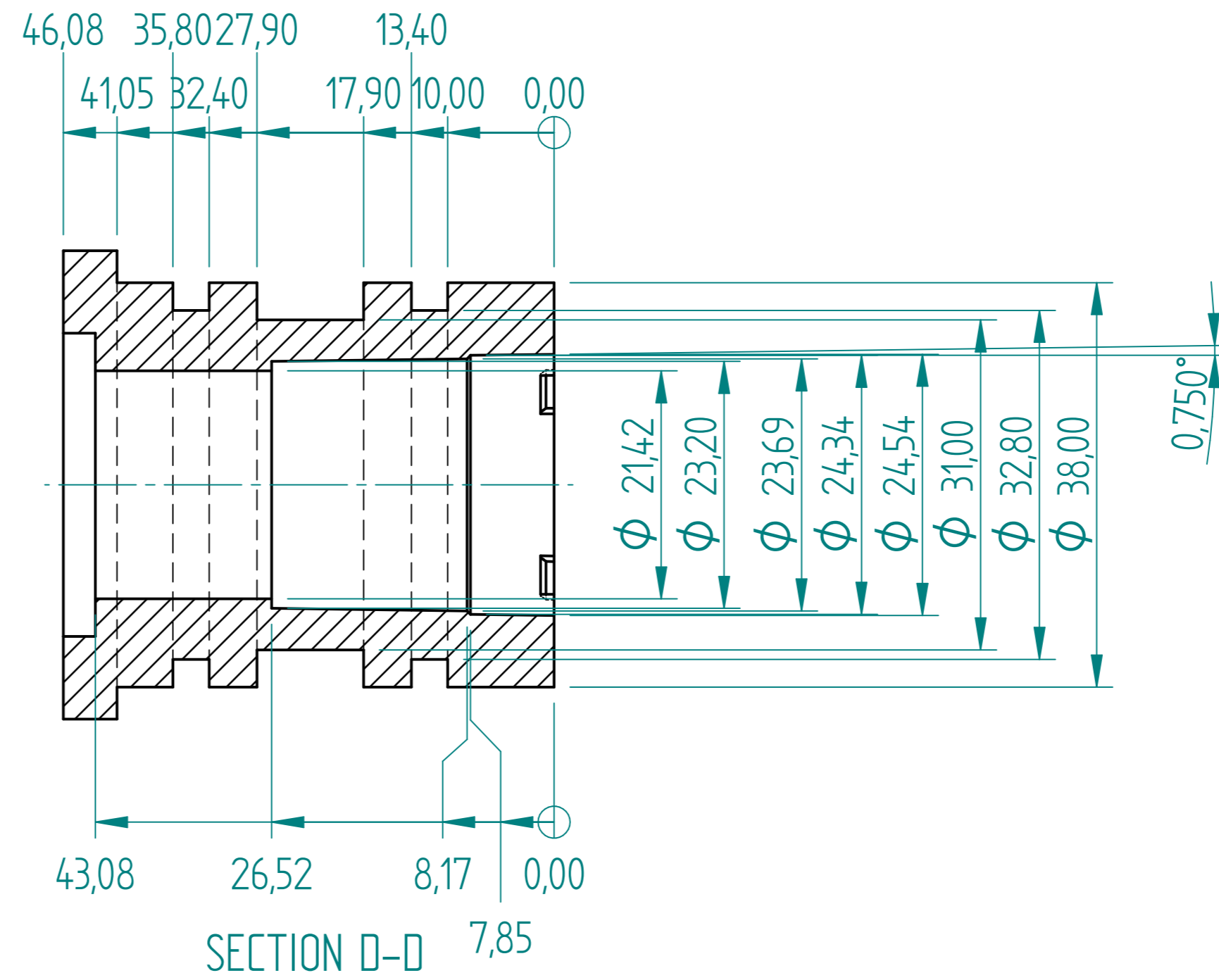
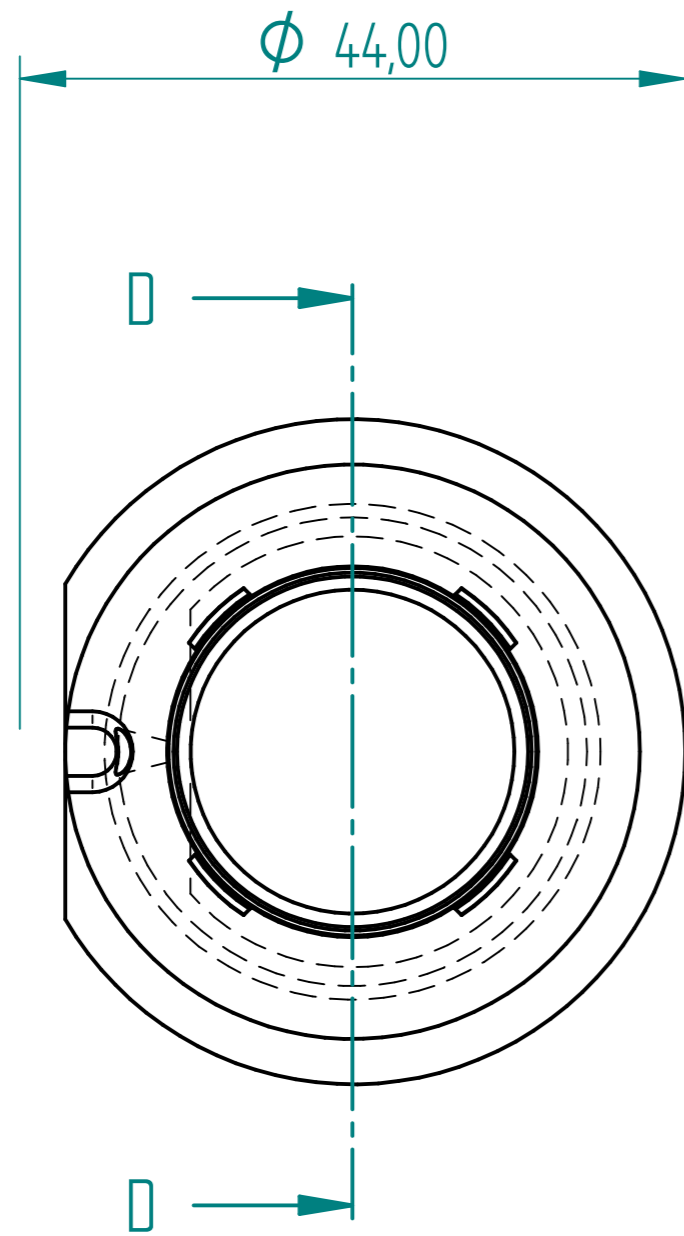

|   |      |          |                             |         |
|---|------|----------|-----------------------------|---------|
|   | NAME | DATE     | <b>PREMAC</b>               |         |
| DRAWN   | Dan  | 09/03/21 |                             |         |
| APPROVED  |      |          |                             |         |
| MATERIAL  |      |          |                             |         |
| TREATMENT   |      |          | TITLE                       |         |
| UNLESS OTHERWISE SPECIFIED<br>DIMENSIONS ARE IN MILLIMETERS |      |          | SIZE<br>A4                  | DWG NO  |
| 1 <sup>ST</sup> ANGLE<br>2 PL ±0.02 3 PL ±0.005             |      |          | FILE NAME: Family Mould.dft | REV     |
|   |      |          | SCALE:                      | WEIGHT: |
|   |      |          | SHEET 5 OF 5                |         |