

Series	HG Series
Block Type	Flange Type
Model Size	20
Load Type	Heavy Load
Block Mounting	Mounting from Top
Block	Standard Block
No. of Blocks per Rail	2
Rail Mounting Type	Mounting From Top
Rail Length	1000
Rail	Standard Rail
Preload Class	Light Preload (0 ~ 0.02C)
Precision Code	C
No. of Rails per Axis Set	1
Dust Protection	Standard protection (End seal and bottom seal)
Reinforced Cap	No

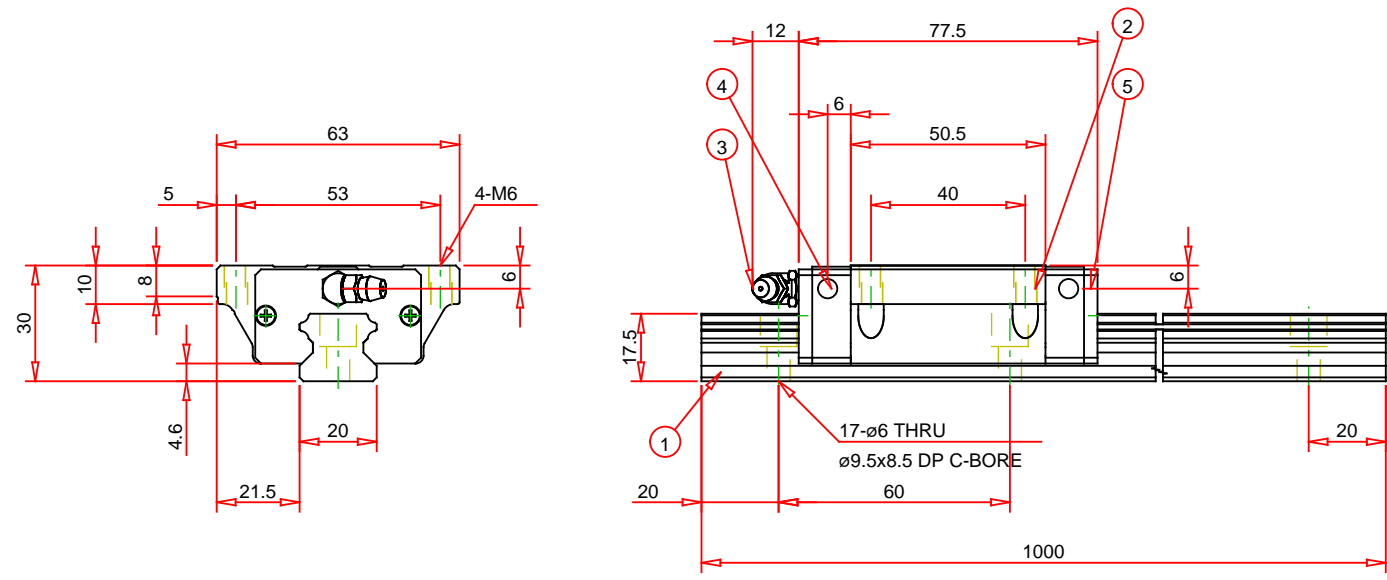

5	End Seal	4
4	End Cap	4
3	Grease Nipple	2
2	Block	2
1	Rail	1
No.	Part Name	Qty

Notes : - Drawing not to scale
 - Dimensions subject to change without notice

Part No. :
 HGW20CA2R1000Z0C

Description :
 HG Series - Non-interchangeable Type



HIWIN
 Motion Control and System Technology

Hiwin Technologies Corp.

Taiwan:
 Address : No. 7, Jingke Road
 Taichung Precision Machinery Park
 Taichung 40852, Taiwan
 Tel. : +886-4-23594510
 Email : business@hiwin.tw
 Web : www.hiwin.tw

Hiwin Corp.

USA:
 Address : 12455 Jim Dhamer Dr
 Huntley, IL 60142
 Tel. : +1-847-827-2270
 Email : info@hiwin.com
 Web : www.hiwin.com