

Series	HG Series
Block Type	Flange Type
Model Size	15
Load Type	Heavy Load
Block Mounting	Mounting from Top
Block	Standard Block
No. of Blocks per Rail	1
Rail Mounting Type	Mounting From Top
Rail Length	1000
Rail	Standard Rail
Preload Class	Light Preload (0 ~ 0.02C)
Precision Code	C
No. of Rails per Axis Set	1
Dust Protection	Standard protection (End seal and bottom seal)
Reinforced Cap	No

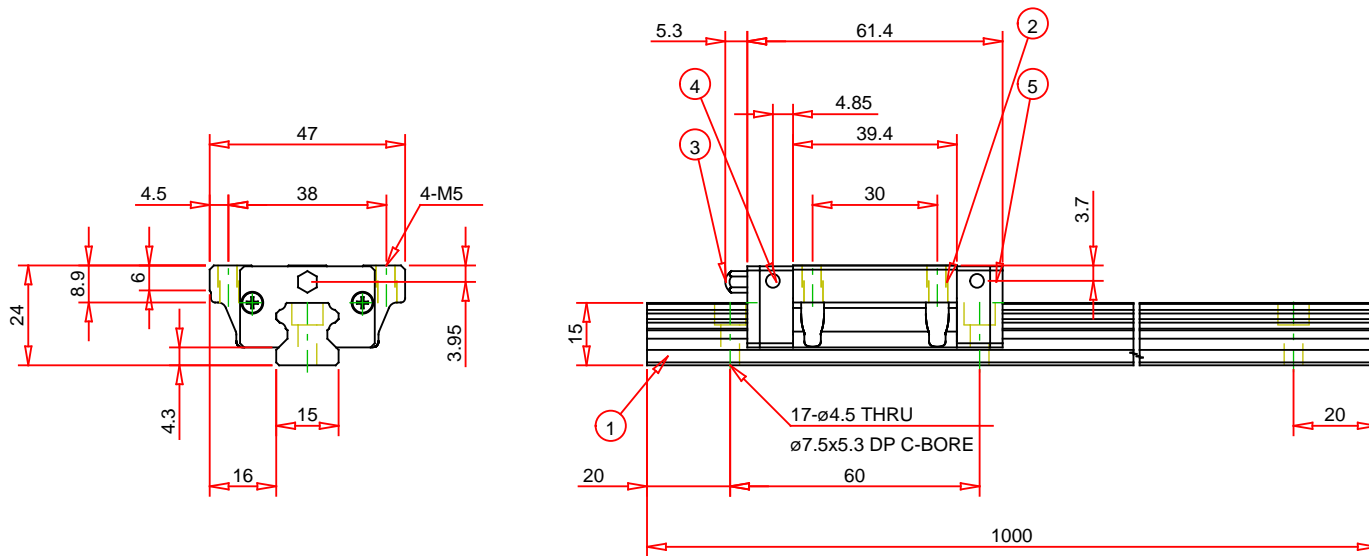

5	End Seal	2
4	End Cap	2
3	Grease Nipple	1
2	Block	1
1	Rail	1
No.	Part Name	Qty

Notes : - Drawing not to scale
- Dimensions subject to change without notice

Part No. :

HGW15CA1R1000Z0C

Description :

HG Series - Non-interchangeable Type

HIWIN
Motion Control and System Technology

Hiwin Technologies Corp.

Taiwan:
Address : No. 7, Jingke Road
Taichung Precision Machinery Park
Taichung 40852, Taiwan
Tel. : +886-4-23594510
Email : business@hiwin.tw
Web : www.hiwin.tw

Hiwin Corp.

USA:
Address : 12455 Jim Dhamer Dr
Huntley, IL 60142
Tel. : +1-847-827-2270
Email : info@hiwin.com
Web : www.hiwin.com