

REVISION HISTORY			
REV	DESCRIPTION	DATE	APPROVED

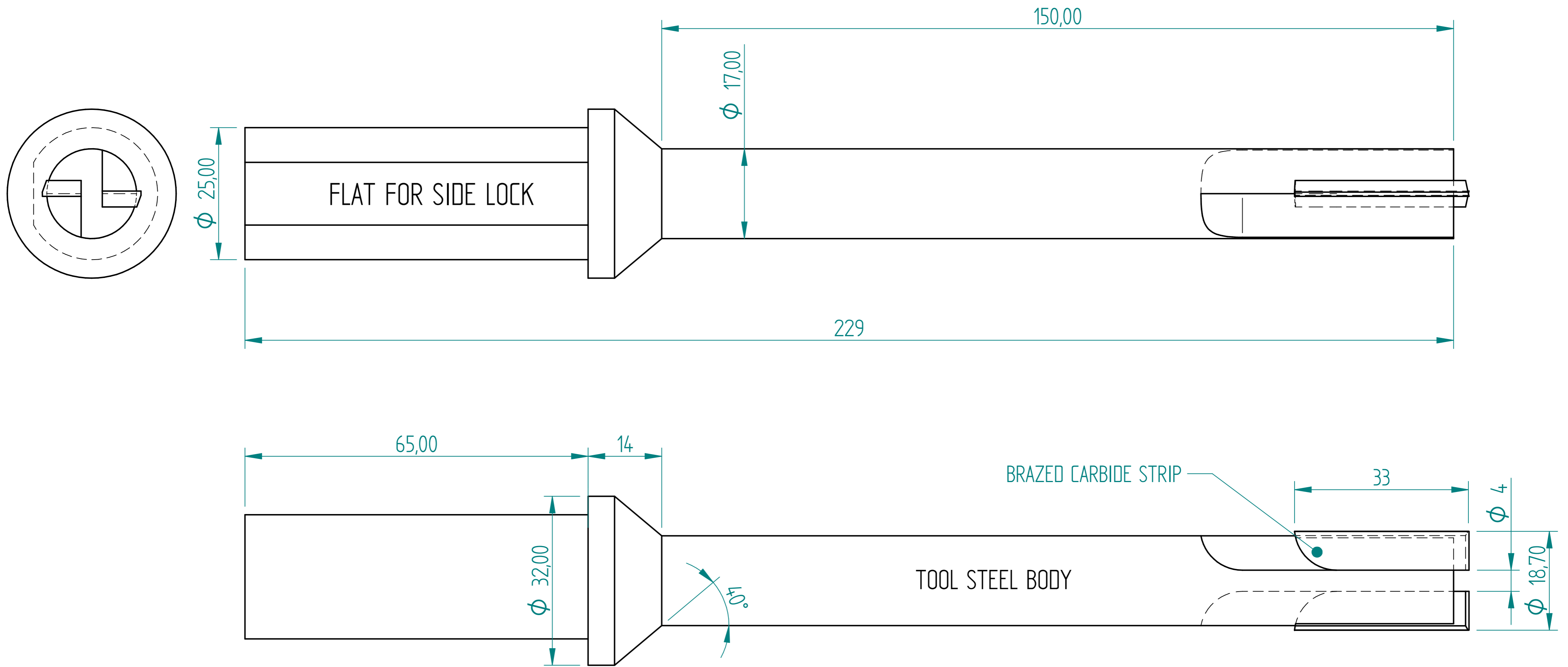

TO CUT DIA18.7 - 150mm IN CAST IRON  
 2 OR 3 BRAZED CARBIDE STRIPS  
 3 IS BETTER IF POSSIBLE

Spool Bar Dia 18.7

	NAME	DATE	<b>PREMAC</b>	
DRAWN	Dan	06/20/19		
APPROVED			TITLE	
MATERIAL				
TREATMENT				
UNLESS OTHERWISE SPECIFIED DIMENSIONS ARE IN MILLIMETERS			SIZE A4	DWG NO
1 <sup>ST</sup> ANGLE ANGLES ±0.1°			FILE NAME: Spool Bar Dia 18.8.dft	
2 PL ±0.02 3 PL ±0.005			SCALE:	WEIGHT: SHEET 1 OF 2

REVISION HISTORY			
REV	DESCRIPTION	DATE	APPROVED

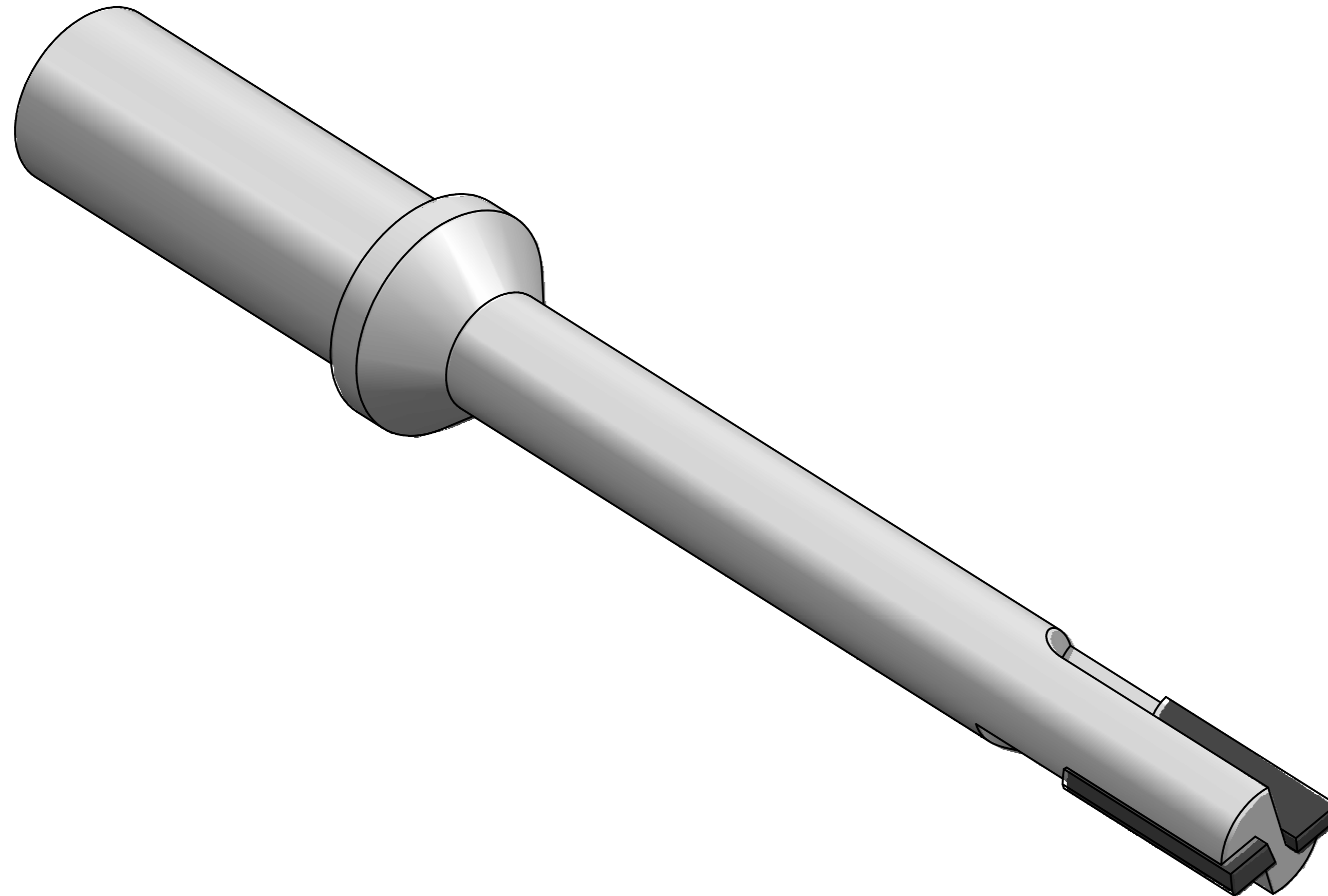

Spool Bar Dia 18.7

	NAME	DATE	<b>PREMAC</b>	
DRAWN	Dan	06/20/19		
APPROVED				
MATERIAL				
TREATMENT			TITLE	
UNLESS OTHERWISE SPECIFIED DIMENSIONS ARE IN MILLIMETERS			SIZE A4	DWG NO
1 <sup>ST</sup> ANGLE  2 PL ±0.02 3 PL ±0.005			FILE NAME: Spool Bar Dia 18.8.dft	REV
			SCALE:	WEIGHT:
			SHEET 2 OF 2	