

REVISION HISTORY			
REV	DESCRIPTION	DATE	APPROVED

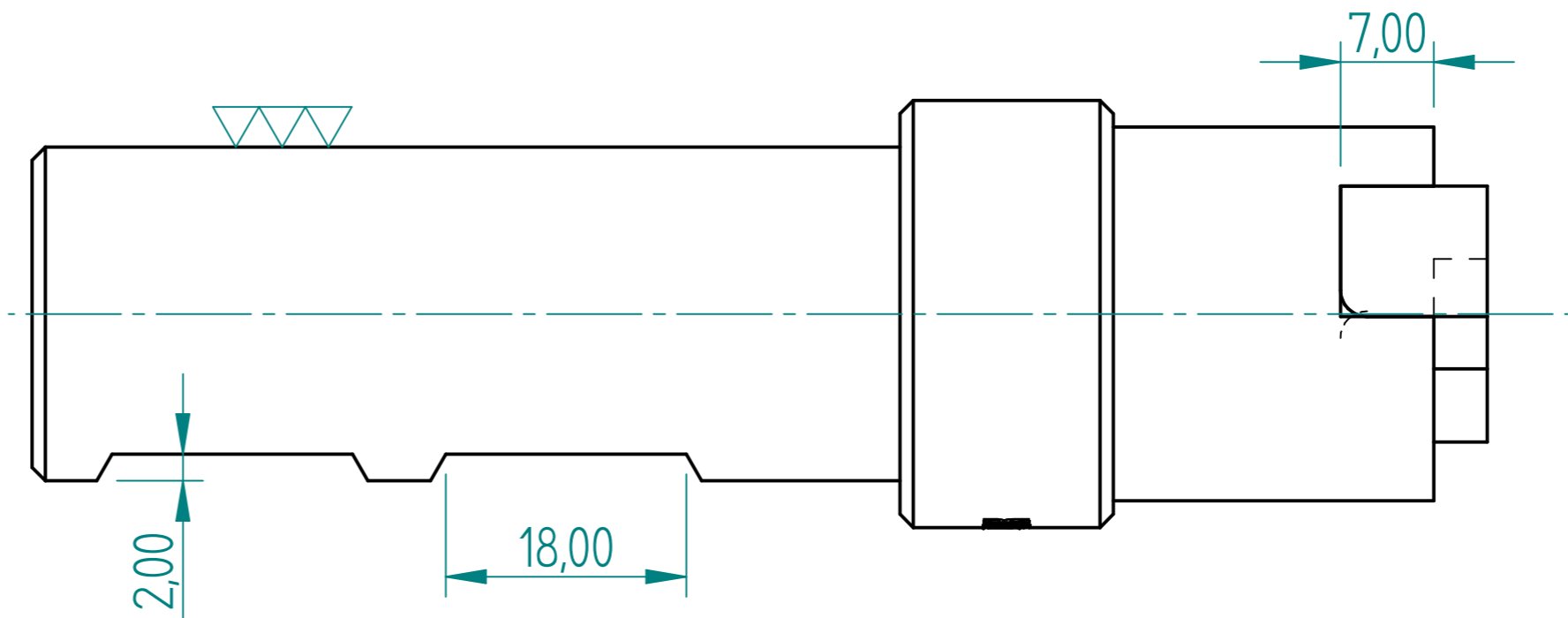

D28 O Ring Groove Bar FOR MACHINING O-RING GROOVE ON FLAT FACE IN CAST IRON

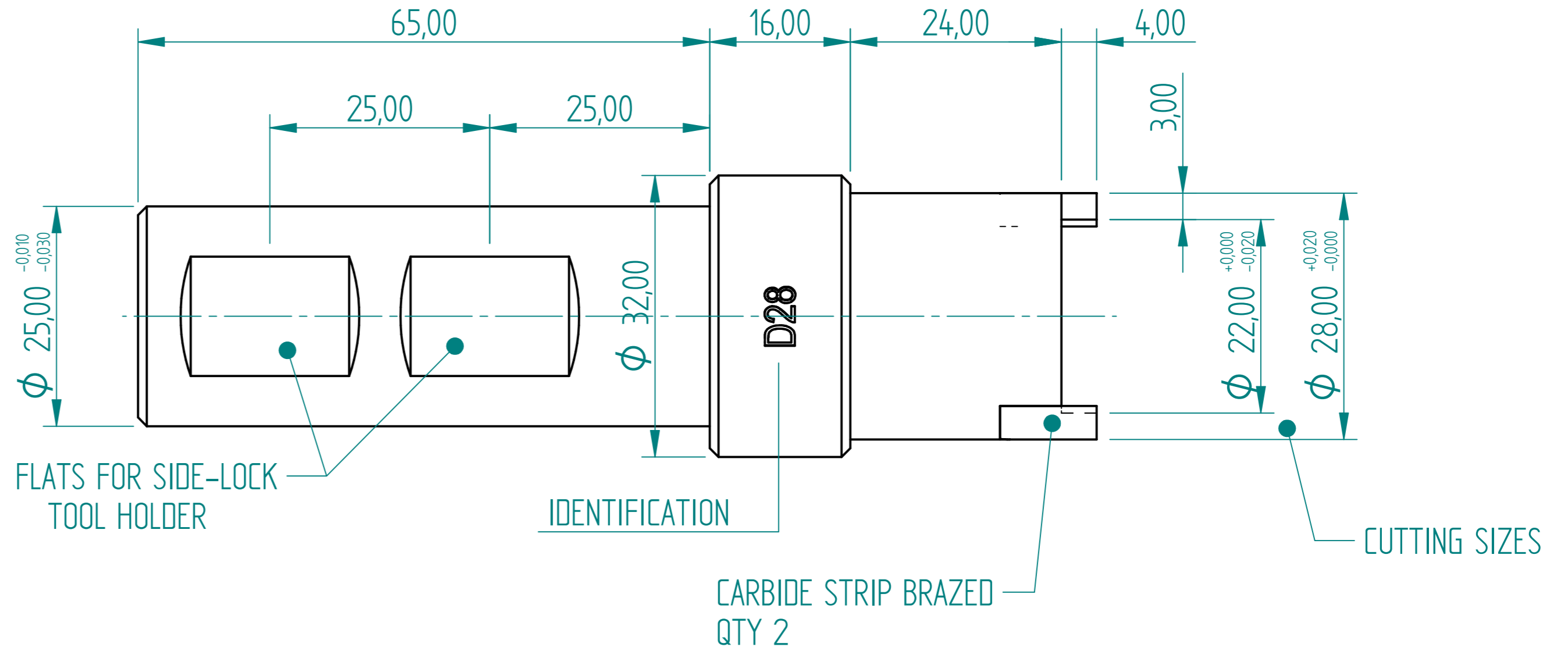
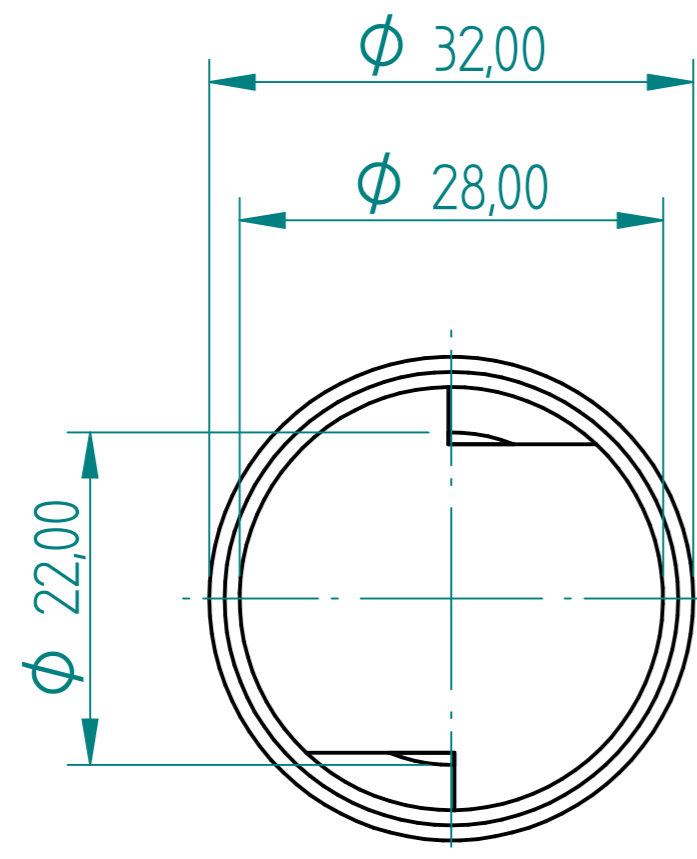
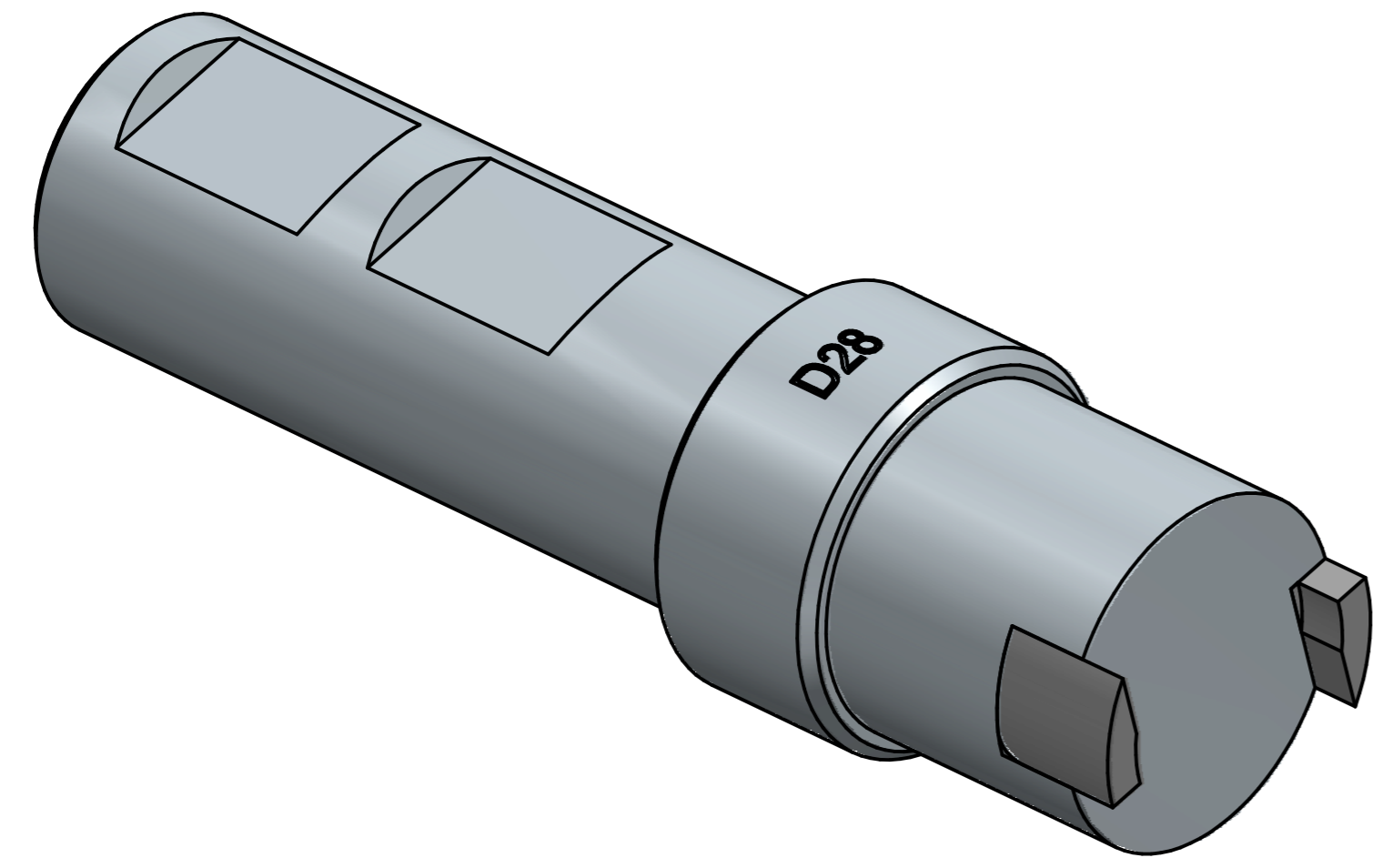

	NAME	DATE	PREMAC		
DRAWN	Dan	09/04/23			
APPROVED			TITLE D28 O Ring Groove Bar		
MATERIAL					
TREATMENT			SIZE A4	DWG NO	REV
UNLESS OTHERWISE SPECIFIED DIMENSIONS ARE IN MILLIMETERS ANGLES $\pm 0.1^\circ$			FILE NAME: D28 O Ring.dft		
1st ANGLE 2 PL ± 0.02 3 PL ± 0.005			SCALE:	WEIGHT:	SHEET 1 OF 1