

REVISION HISTORY			
REV	DESCRIPTION	DATE	APPROVED

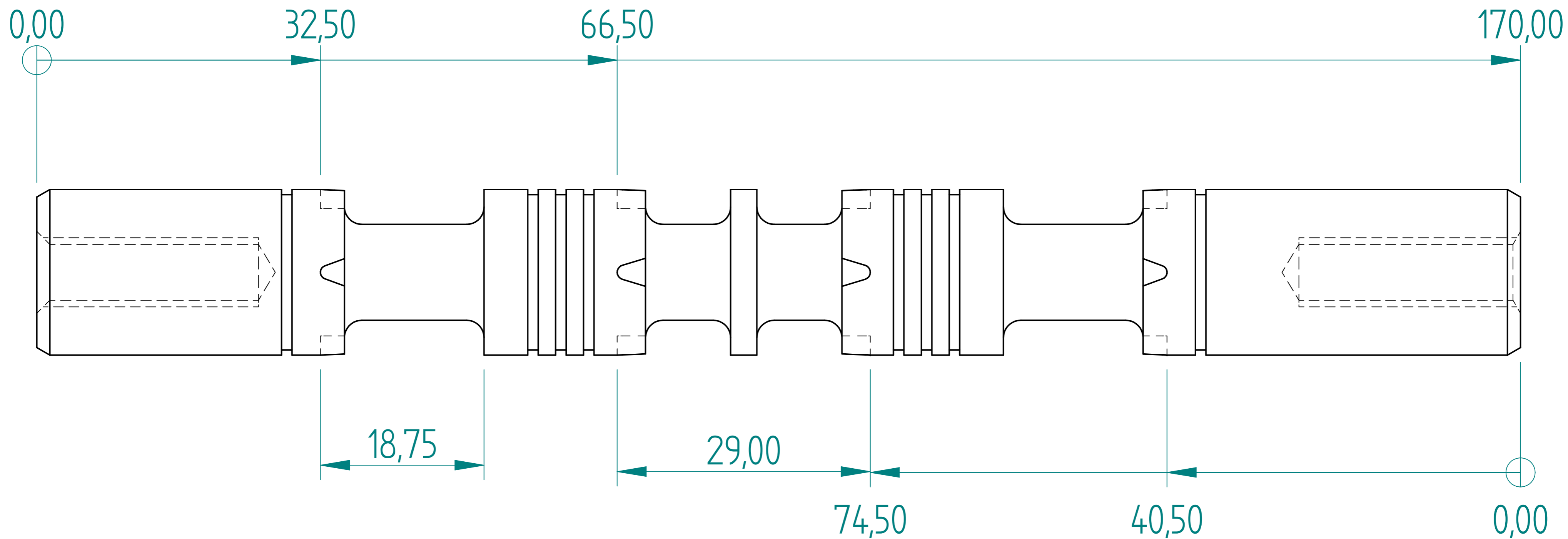

	NAME	DATE	PREMAC	
DRAWN	Dan	09/04/23	PRECISION MACHINE MANUFACTURERS (PTY)LTD.	
APPROVED			TITLE	
MATERIAL				
TREATMENT				
UNLESS OTHERWISE SPECIFIED DIMENSIONS ARE IN MILLIMETERS			SIZE A2	DWG NO
1 ST ANGLE ANGLES ±0.1°			FILE NAME: Spool Std.dft	REV
2 PL ±0.02 3 PL ±0.005			SCALE:	WEIGHT:
			SHEET 1 OF 2	

REVISION HISTORY			
REV	DESCRIPTION	DATE	APPROVED

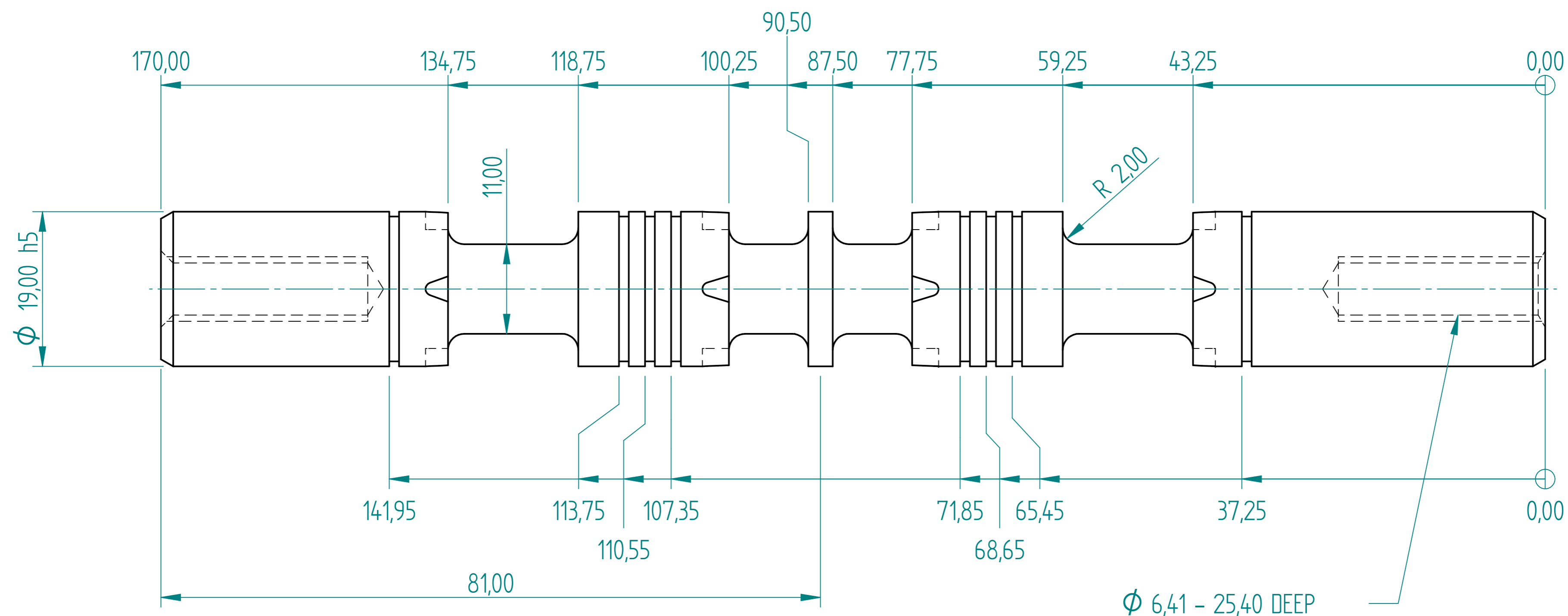

MACHINE DIA 19.1
 PRE-GRIND DIA 18.9
 HARD CHROME TO DIA 19.3
 FINAL GRIND DIA 19.0

Φ 6,41 - 25,40 DEEP
 C'SINK Φ 9,40 X 120,0°
 5/16-18 UNC - 25,40 DEEP

	NAME	DATE	PREMAC	
DRAWN	Dan	09/04/23	PRECISION MACHINE MANUFACTURERS (PTY)LTD.	
APPROVED			TITLE	
MATERIAL			SIZE	DWG NO
TREATMENT			A2	
UNLESS OTHERWISE SPECIFIED DIMENSIONS ARE IN MILLIMETERS			FILE NAME: Spool Std.dft	REV
1st ANGLE			SCALE:	WEIGHT:
2 PL ±0.02 3 PL ±0.005				SHEET 2 OF 2