

REVISION HISTORY			
REV	DESCRIPTION	DATE	APPROVED

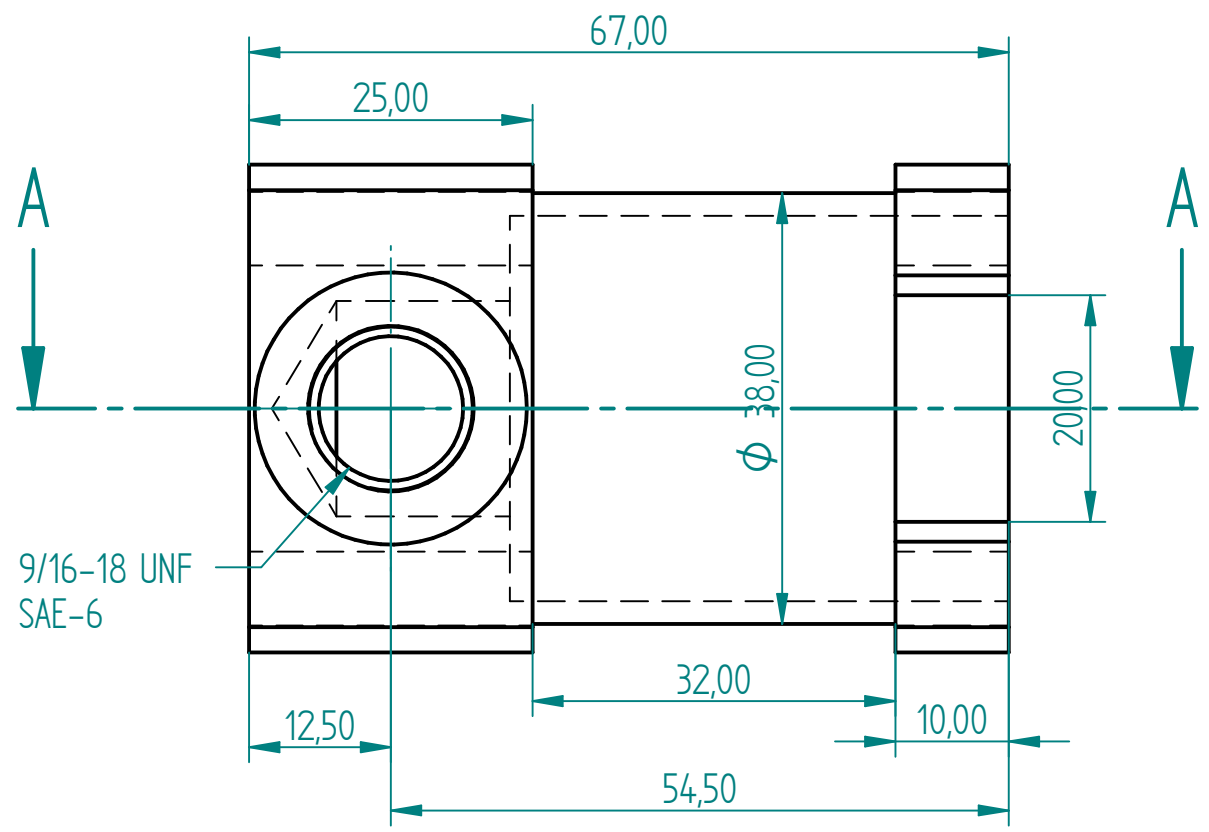

9/16-18 UNF  
SAE-6

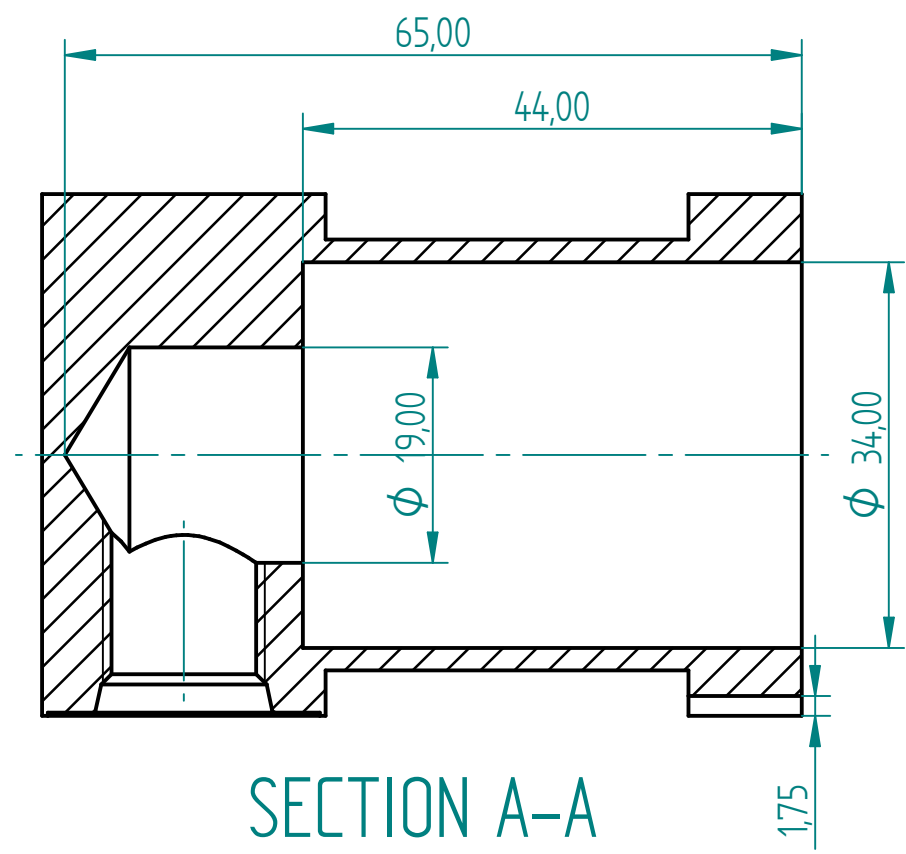
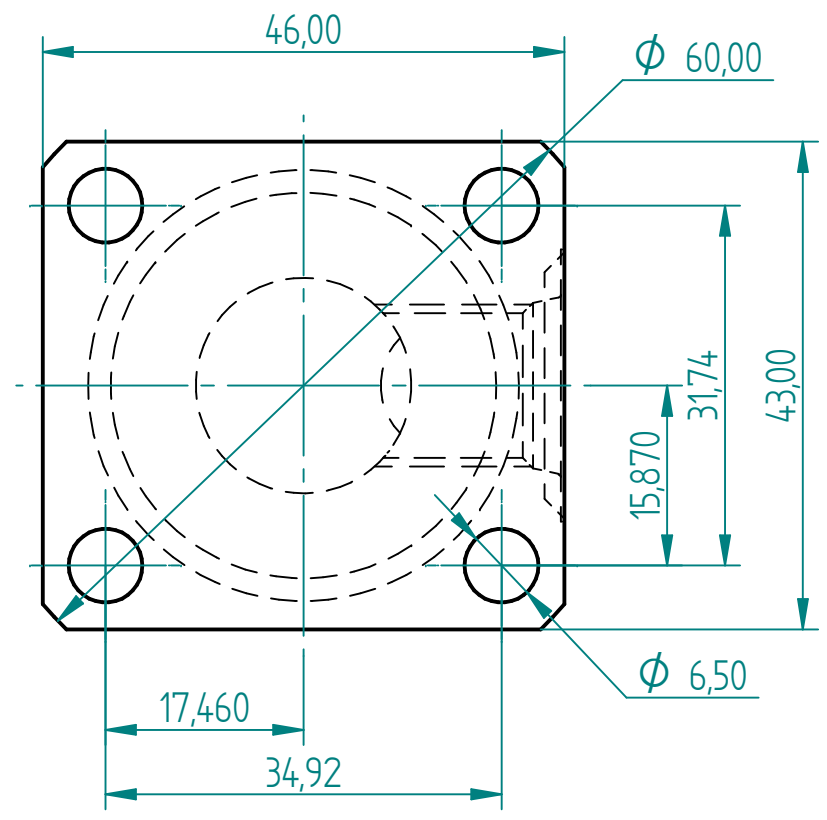

SECTION A-A

DRAWN		NAME	DATE	PREMAC PRECISION MACHINE MANUFACTURERS (PTY)LTD.	
APPROVED		D.L.G.	09/04/23		
MATERIAL		Mild Steel	0.418kg	TITLE V75 STD HYD REM BONNET	
TREATMENT		Zink Plate		SIZE A3	DWG NO V75-
UNLESS OTHERWISE SPECIFIED DIMENSIONS ARE IN MILLIMETERS ANGLES ±0.1° 1st ANGLE		2 PL ±0.02 3 PL ±0.005		FILE NAME: Std Hyd Rem Bonnet Steel.dft	REV
		SCALE:	WEIGHT:	SHEET 1 OF 1	