

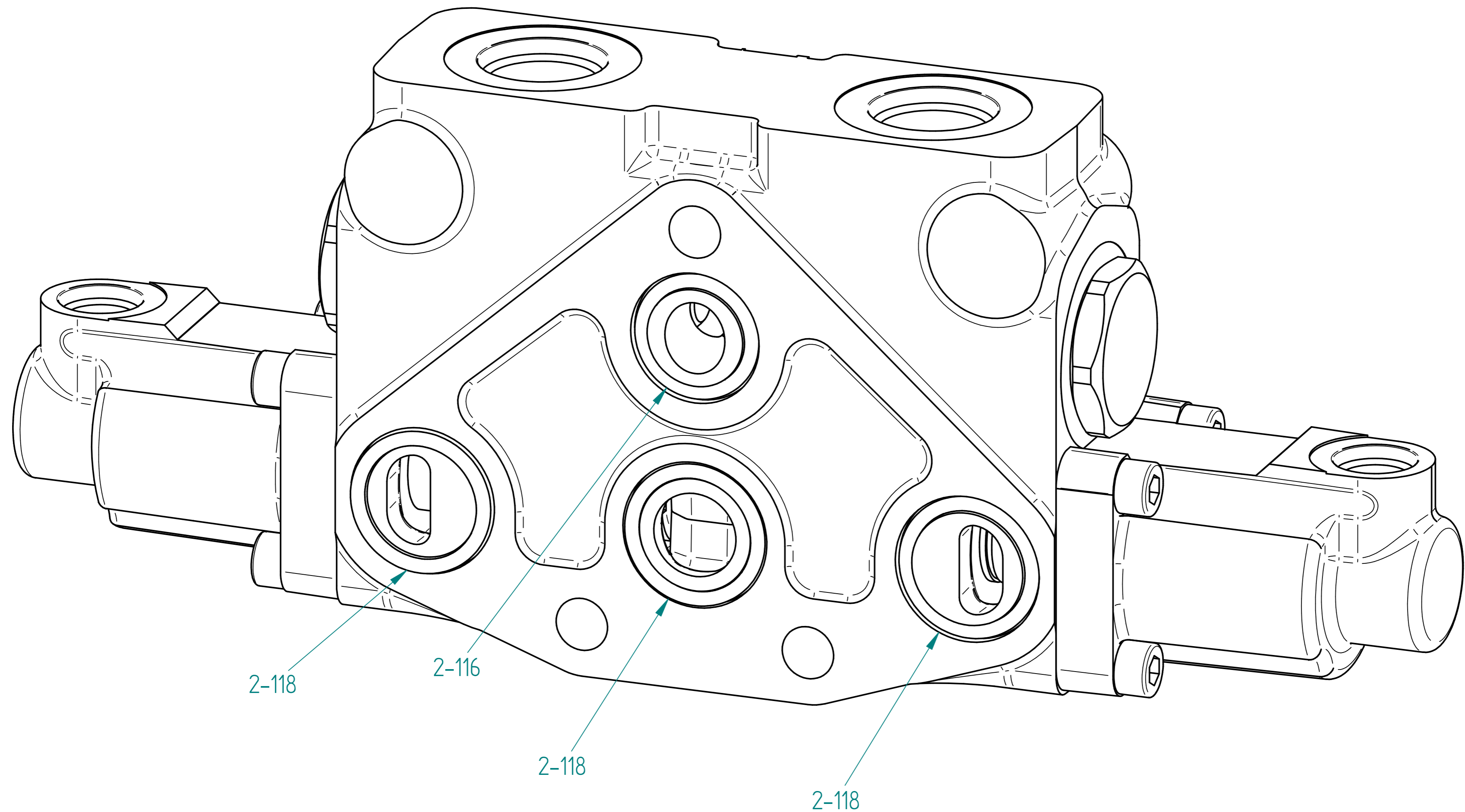

REVISION HISTORY			
REV	DESCRIPTION	DATE	APPROVED



# V75 STD HYDRAULIC REMOTE

	NAME	DATE	PREMAC	
DRAWN	Dan	09/04/23	PRECISION MACHINE MANUFACTURERS (PTY)LTD.	
APPROVED			TITLE	V75 Std Hydraulic Remote
MATERIAL			SIZE	DWG NO
TREATMENT			A2	V75-
UNLESS OTHERWISE SPECIFIED DIMENSIONS ARE IN MILLIMETERS			FILE NAME:	Std Hydraulic Remote.dft
1 <sup>ST</sup> ANGLE 			SCALE:	WEIGHT:
2 PL ±0.02 3 PL ±0.005				SHEET 1 OF 6

Item Number	Document Number	Title	Quantity	Item Number	Document Number	Title	Quantity
1			1	10	P75-0087	H R Positioner Sleeve	1
2	M6-20	Cap Screw	8	11	P75-0088	H R Spring Outer	1
3	P1.3 x 32.7	O-Ring	2	12	P75-0089	H R Spring Inner	1
4	P2-023	O-Ring	2	13	P75-0092	H R Spring Cup	1
5	P2-210	O-Ring	2	14	P75-0093	H R SPOOL SEALING WASHER	2
6	P75-0020	Spool Std	1	15	P75-0094	H R Spool Positioner	1
7*	P75-0045	Spool Clevis	1	16	P75-0097	H R Positioner Washer	1
8*	P75-0050	Spool Sealing Washer	2	17*	PWS-08	Spring Washer	1
9	P75-0085	H R BONNET	2	18	V75-RP	Port Relief Plug Ass	2

REVISION HISTORY			
REV	DESCRIPTION	DATE	APPROVED

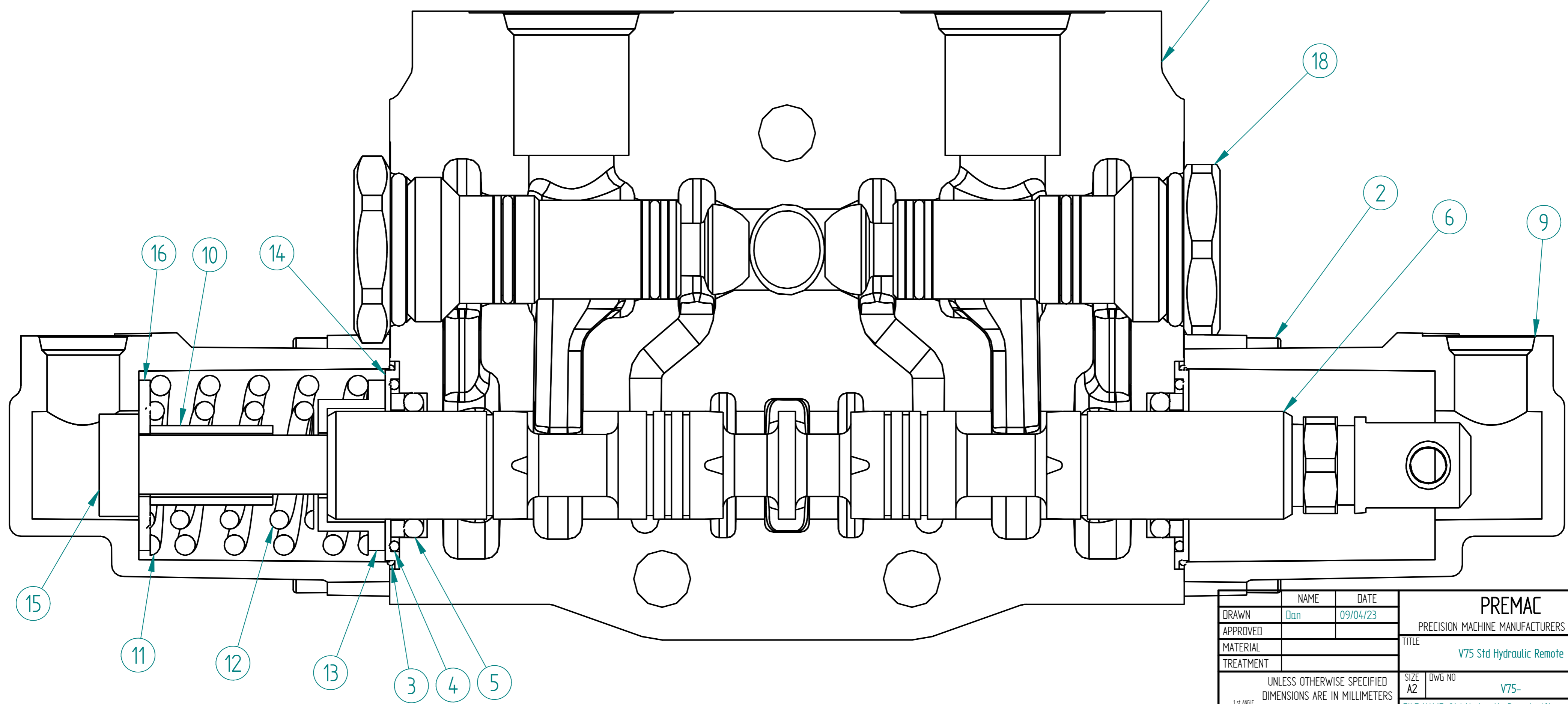

DRAWN	NAME	DATE	PREMAC	
APPROVED	Dan	09/04/23	PRECISION MACHINE MANUFACTURERS (PTY)LTD.	
MATERIAL			TITLE	
TREATMENT			V75 Std Hydraulic Remote	
UNLESS OTHERWISE SPECIFIED DIMENSIONS ARE IN MILLIMETERS ANGLES ±0.1°			SIZE A2	DWG NO V75-
1st ANGLE SCALE: 2 PL ±0.02 3 PL ±0.005			FILE NAME: Std Hydraulic Remote.dft	REV
			SCALE:	WEIGHT:
			SHEET 2 OF 6	

REVISION HISTORY			
REV	DESCRIPTION	DATE	APPROVED

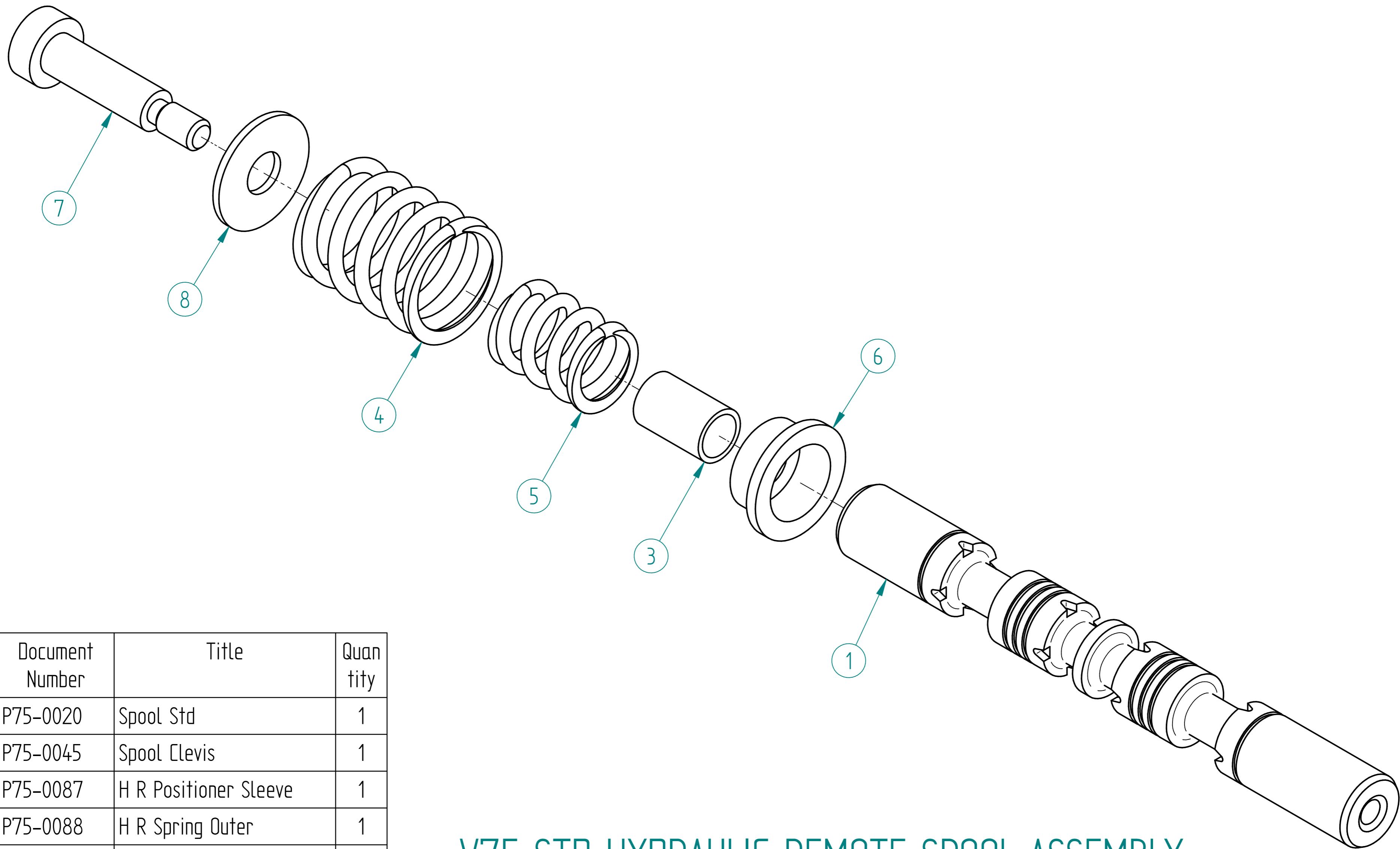

## V75 STD HYDRAULIC REMOTE SPOOL ASSEMBLY

Item Number	Document Number	Title	Quantity
1	P75-0020	Spool Std	1
2*	P75-0045	Spool Clevis	1
3	P75-0087	H R Positioner Sleeve	1
4	P75-0088	H R Spring Outer	1
5	P75-0089	H R Spring Inner	1
6	P75-0092	H R Spring Cup	1
7	P75-0094	H R Spool Positioner	1
8	P75-0097	H R Positioner Washer	1
9*	PWS-08	Spring Washer	1

	NAME	DATE	PREMAC	
DRAWN	Dan	09/04/23	PRECISION MACHINE MANUFACTURERS (PTY)LTD.	
APPROVED			TITLE	
MATERIAL			V75 Std Hydraulic Remote	
TREATMENT			SIZE	DWG NO
UNLESS OTHERWISE SPECIFIED DIMENSIONS ARE IN MILLIMETERS ANGLES ±0.1° 1 <sup>ST</sup> ANGLE			A2	V75-
			SCALE:	WEIGHT:
2 PL ±0.02 3 PL ±0.005			REV	SHEET 3 OF 6

REVISION HISTORY			
REV	DESCRIPTION	DATE	APPROVED

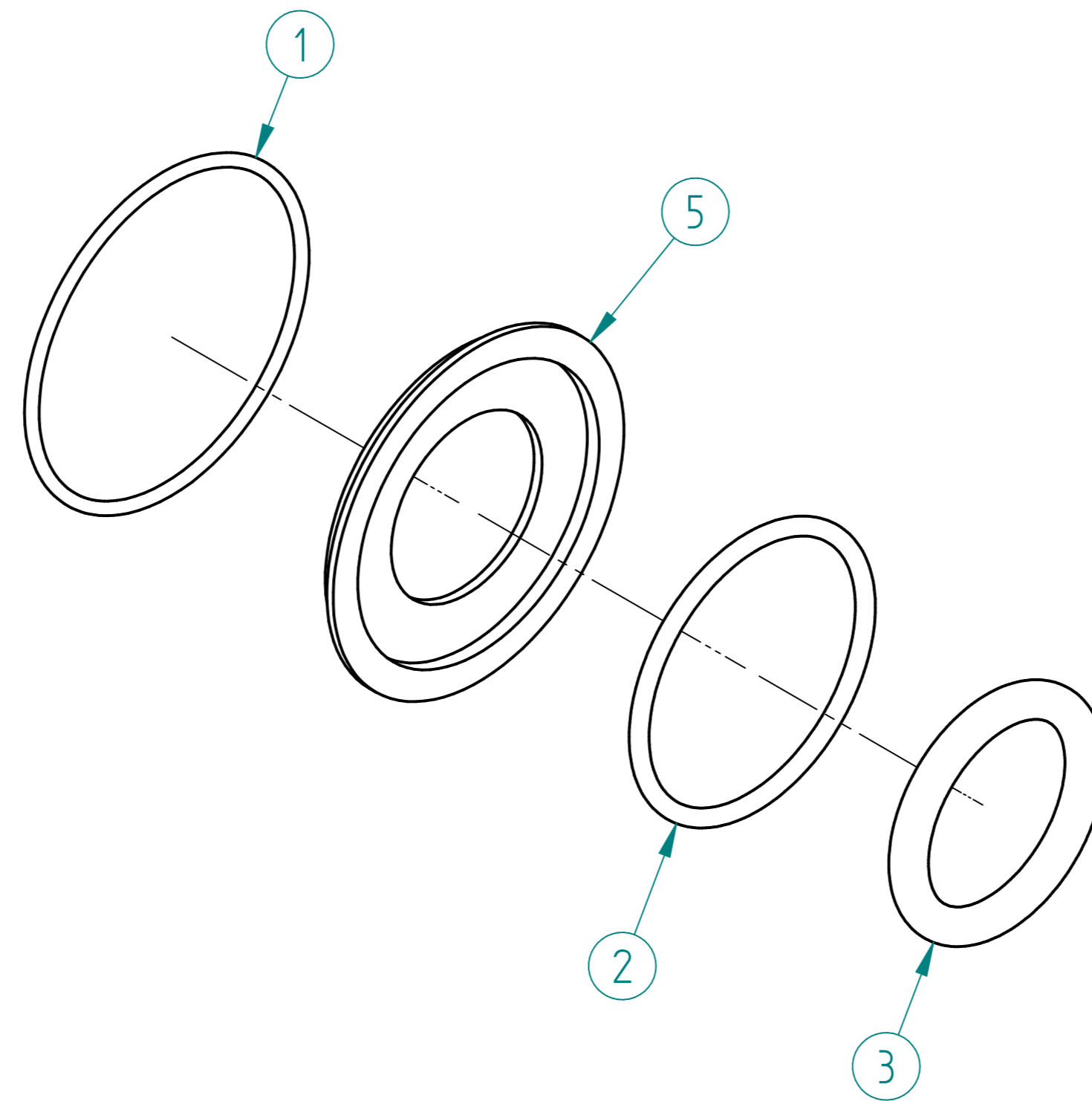

Item Number	Document Number	Title	Quantity
1	P1.3 x 32.7	O-Ring	1
2	P2-023	O-Ring	1
3	P2-210	O-Ring	1
4*	P75-0050	Spool Sealing Washer	1
5	P75-0093	H R SPOOL SEALING WASHER	1

## V75 HYD REMOTE SPOOL SEALING ASSEMBLY

	NAME	DATE	PREMAC	
DRAWN	Dan	09/04/23	PRECISION MACHINE MANUFACTURERS (PTY)LTD.	
APPROVED			TITLE	
MATERIAL			V75 Std Hydraulic Remote	
TREATMENT			SIZE	DWG NO
UNLESS OTHERWISE SPECIFIED DIMENSIONS ARE IN MILLIMETERS ANGLES ±0.1° 1 <sup>ST</sup> ANGLE			A2	V75-
			SCALE:	WEIGHT:
2 PL ±0.02 3 PL ±0.005			REV	SHEET 4 OF 6

REVISION HISTORY			
REV	DESCRIPTION	DATE	APPROVED

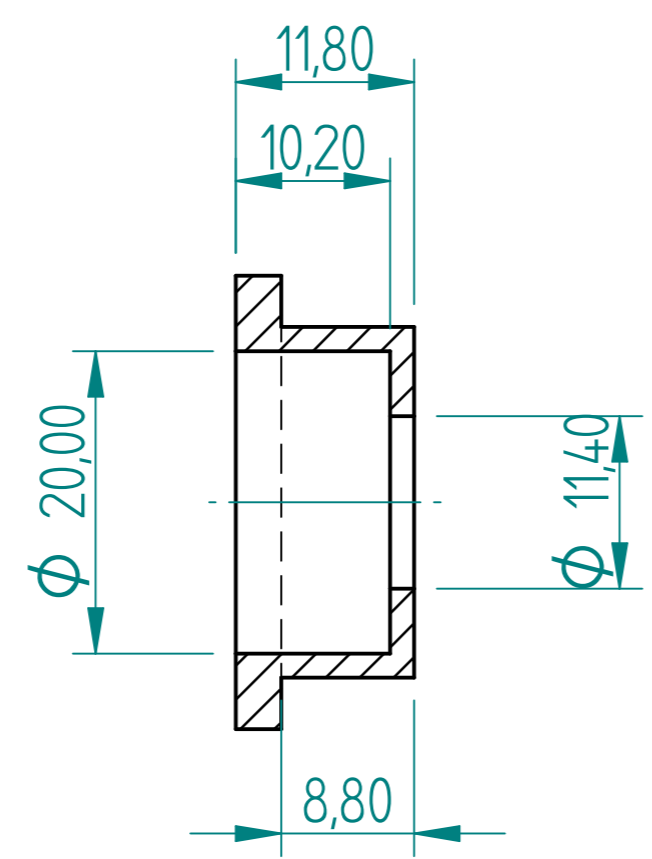
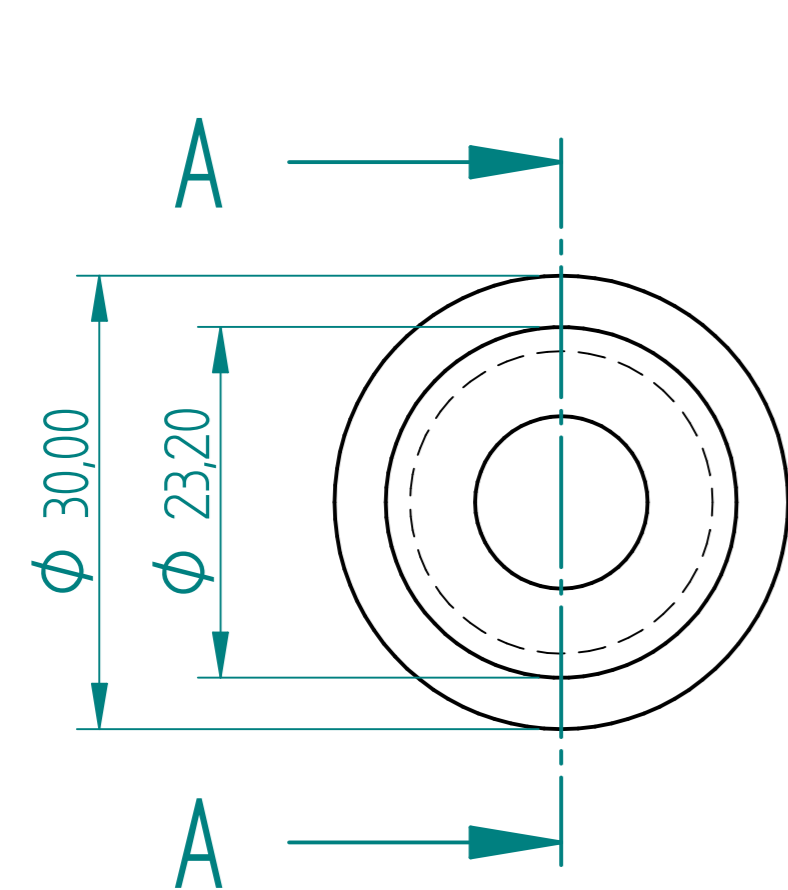
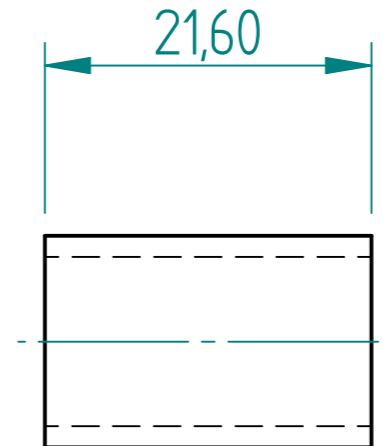
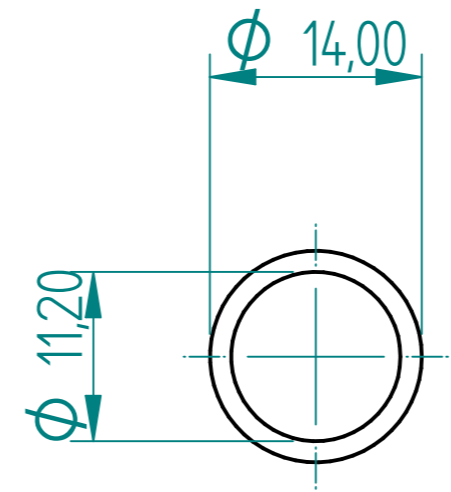
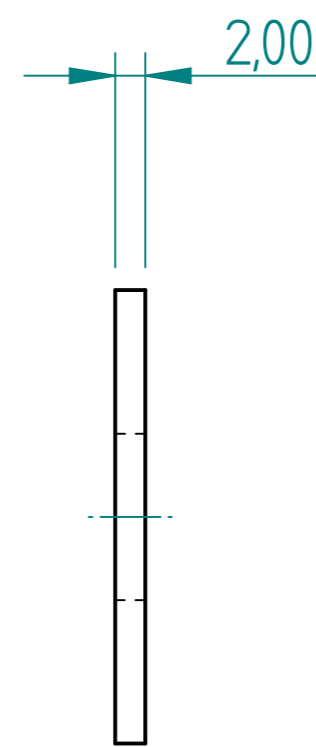
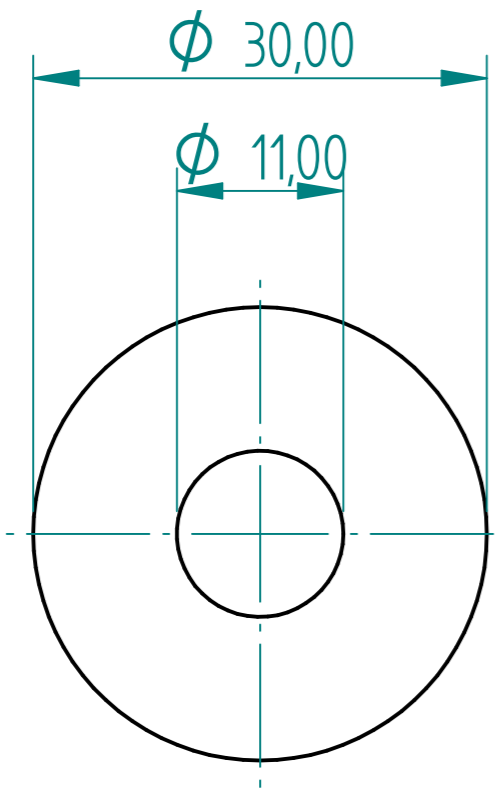

SECTION A-A

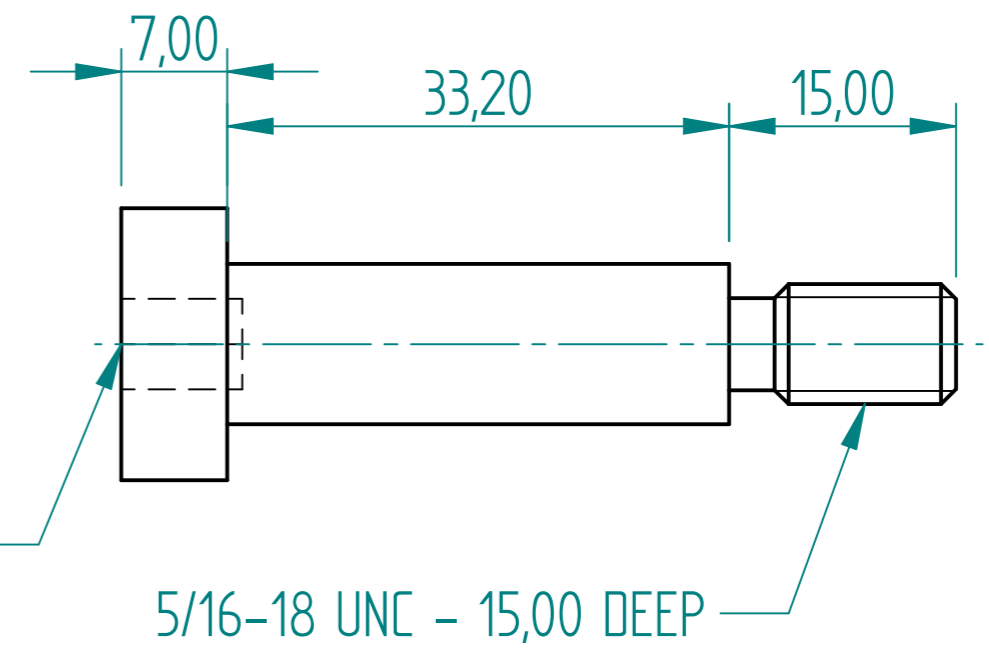
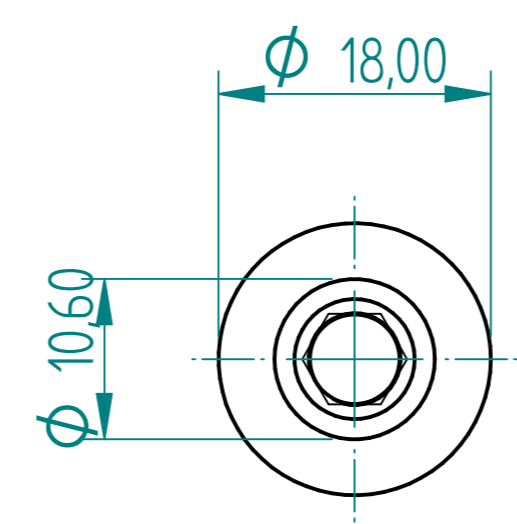

	NAME	DATE	PREMAC	
DRAWN	Dan	09/04/23	PRECISION MACHINE MANUFACTURERS (PTY)LTD.	
APPROVED			TITLE	
MATERIAL			V75 Std Hydraulic Remote	
TREATMENT			SIZE	DWG NO
UNLESS OTHERWISE SPECIFIED DIMENSIONS ARE IN MILLIMETERS ANGLES ±0.1° 1st ANGLE			A2	V75-
			FILE NAME: Std Hydraulic Remote.dft	REV
2 PL ±0.02 3 PL ±0.005			SCALE:	WEIGHT:
			SHEET 5 OF 6	

REVISION HISTORY			
REV	DESCRIPTION	DATE	APPROVED

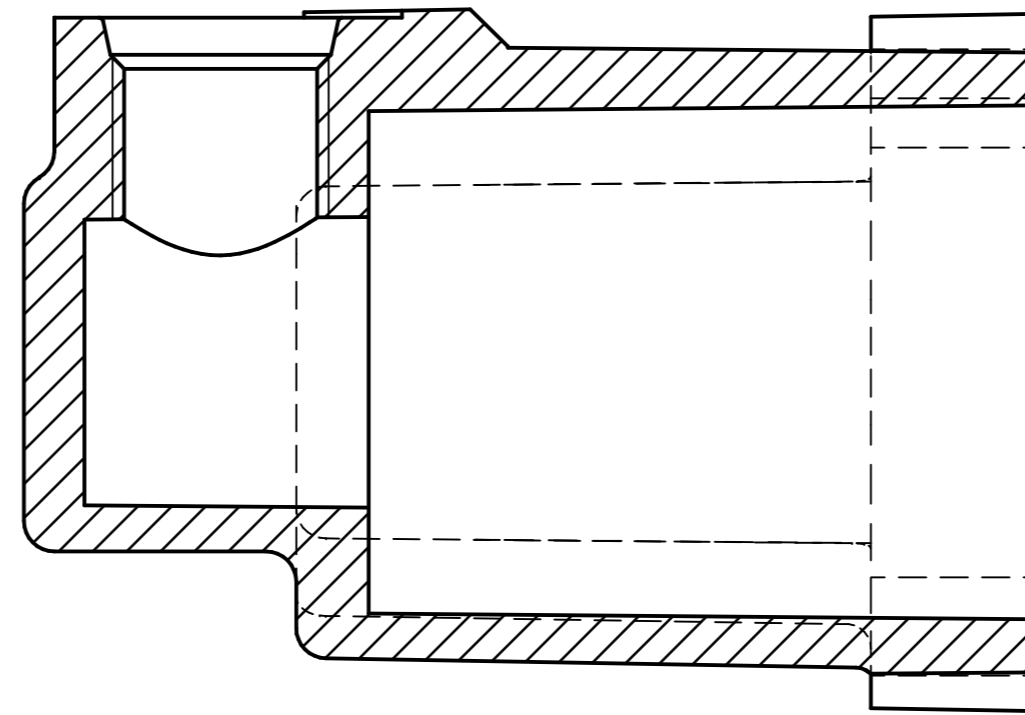
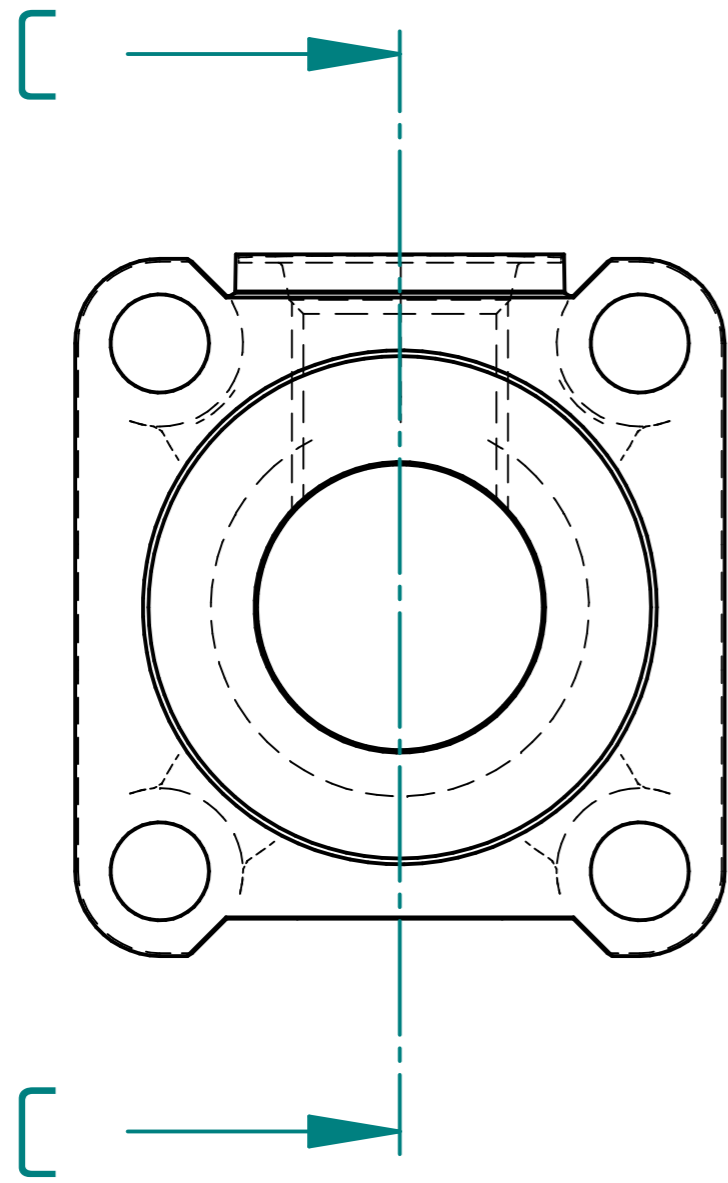

SECTION C-C

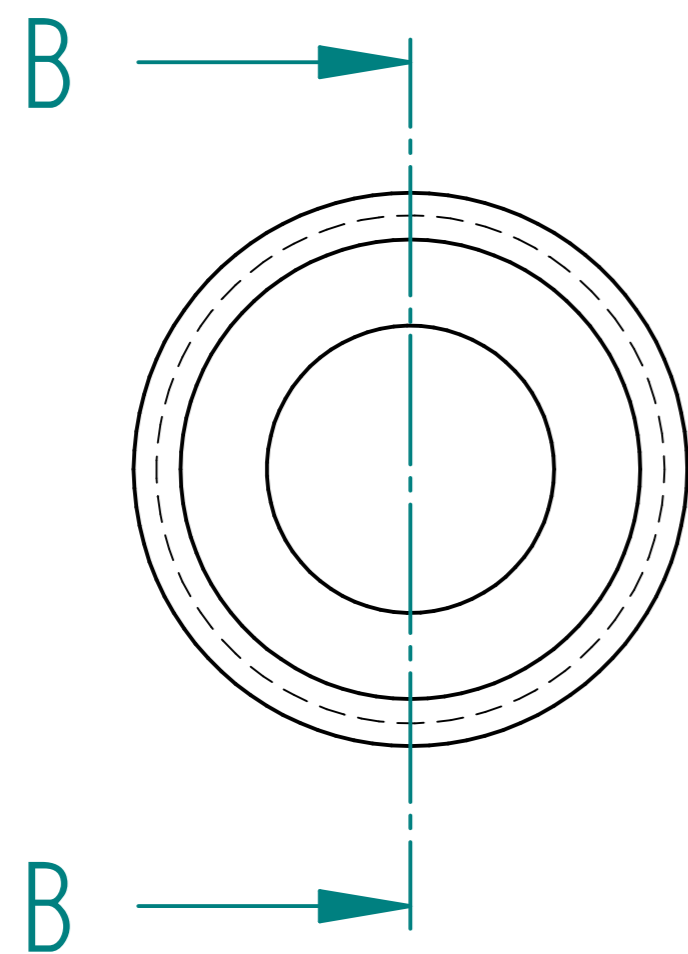

SECTION B-B

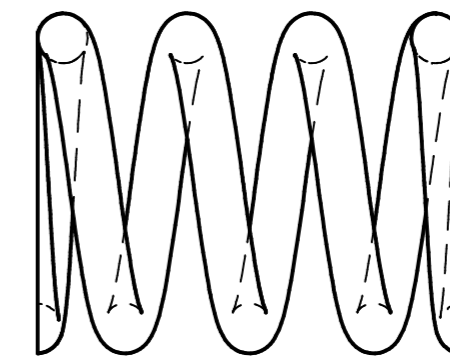
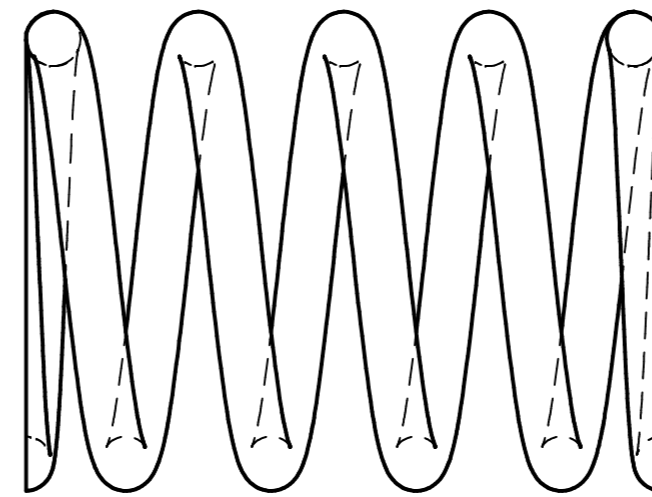

	NAME	DATE	PREMAC	
DRAWN	Dan	09/04/23	PRECISION MACHINE MANUFACTURERS (PTY)LTD.	
APPROVED			TITLE	
MATERIAL			V75 Std Hydraulic Remote	
TREATMENT			SIZE	DWG NO
UNLESS OTHERWISE SPECIFIED DIMENSIONS ARE IN MILLIMETERS ANGLES ±0.1° 1st ANGLE			A2	V75-
			SCALE:	WEIGHT:
2 PL ±0.02 3 PL ±0.005			FILE NAME: Std Hydraulic Remote.dft	REV
			SHEET 6 OF 6	