

REVISION HISTORY			
REV	DESCRIPTION	DATE	APPROVED

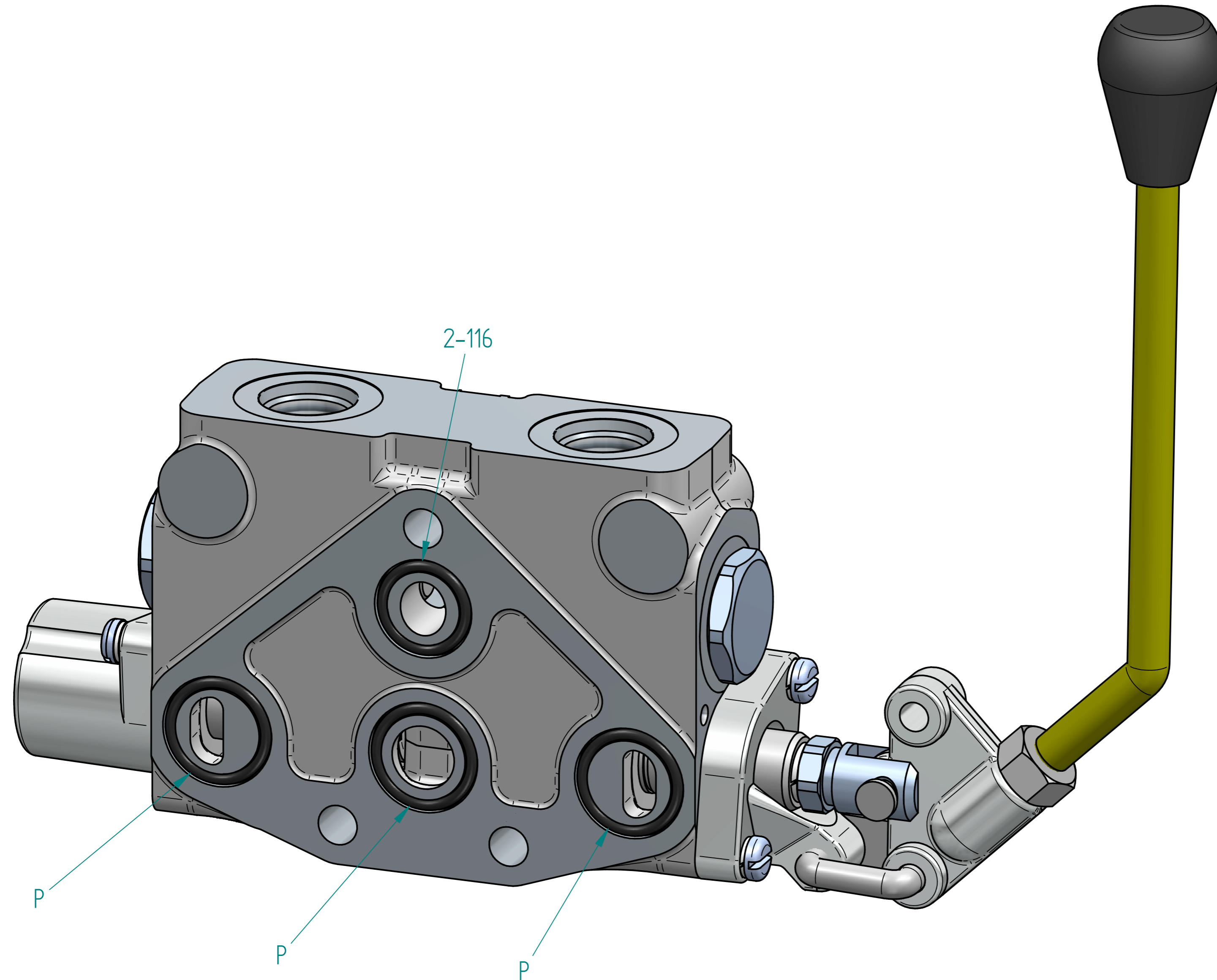

V75 STD CENTRE SECTION

	NAME	DATE	PREMAC	
DRAWN	Dan	09/04/23	PRECISION MACHINE MANUFACTURERS (PTY)LTD.	
APPROVED			TITLE	V75 Std 4 Way
MATERIAL			SIZE	DWG NO
TREATMENT			A2	V75-CS-4WAY
UNLESS OTHERWISE SPECIFIED DIMENSIONS ARE IN MILLIMETERS			FILE NAME: Std 4 Way.dft	REV
1st ANGLE ANGLES ±0.1°			SCALE:	WEIGHT:
2 PL ±0.02 3 PL ±0.005				SHEET 1 OF 7

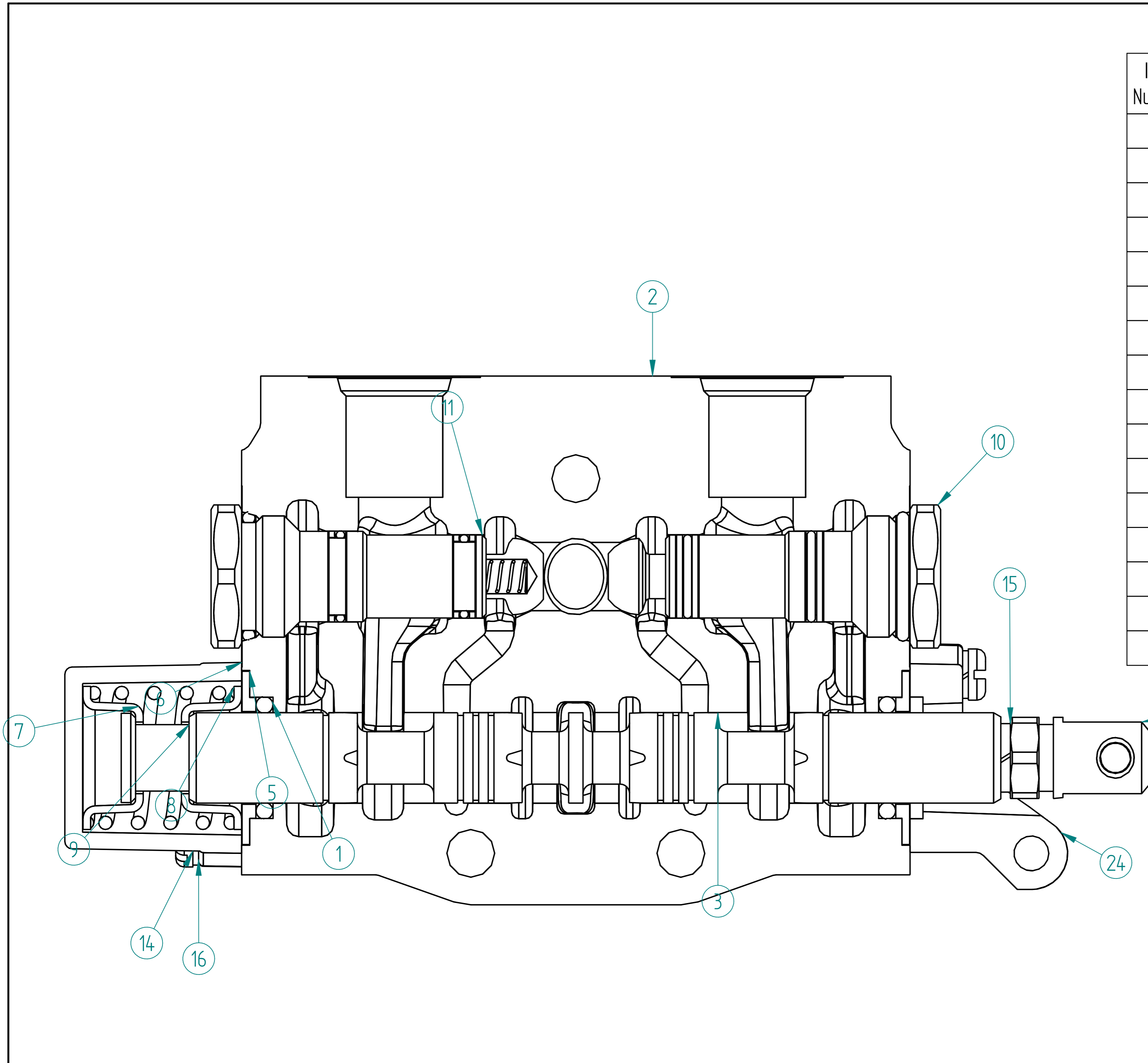

REVISION HISTORY			
REV	DESCRIPTION	DATE	APPROVED

Item Number	Document Number	Title	Quantity
1	P2-210	O-Ring	1
2	P75-0010	Std Center Section	1
3	P75-0020	Spool Std	1
4	P75-0045	Spool Clevis	1
5	P75-0050	Spool Sealing Washer	1
6	P75-0055	Std Bonnet	1
7	P75-0056	Spring Cup	1
8	P75-0057	Std Spool Spring	1
9	P75-0058	Spool Positioner	1
10	P75-0125	Port Relief Plug	1
11	P75-0130	Port Relief Housing	1
12	P75-0150	V75 Handle Bracket	1
13	P75-0151	Spool Boot	1
14	PSM6-25	Screw C H	1
15	PWS-08	Spring Washer	1
16	PWS-6	Spring Washer	1

	NAME	DATE	PREMAC	
DRAWN	Dan	09/04/23	PRECISION MACHINE MANUFACTURERS (PTY)LTD.	
APPROVED			TITLE	
MATERIAL			V75 Std 4 Way	
TREATMENT			SIZE	DWG NO
UNLESS OTHERWISE SPECIFIED DIMENSIONS ARE IN MILLIMETERS ANGLES ±0.1° 1 ST ANGLE			A2	V75-CS-4WAY
			FILE NAME: Std 4 Way.dft	REV
SCALE: 2 PL ±0.02 3 PL ±0.005			WEIGHT:	SHEET 2 OF 7

REVISION HISTORY			
REV	DESCRIPTION	DATE	APPROVED

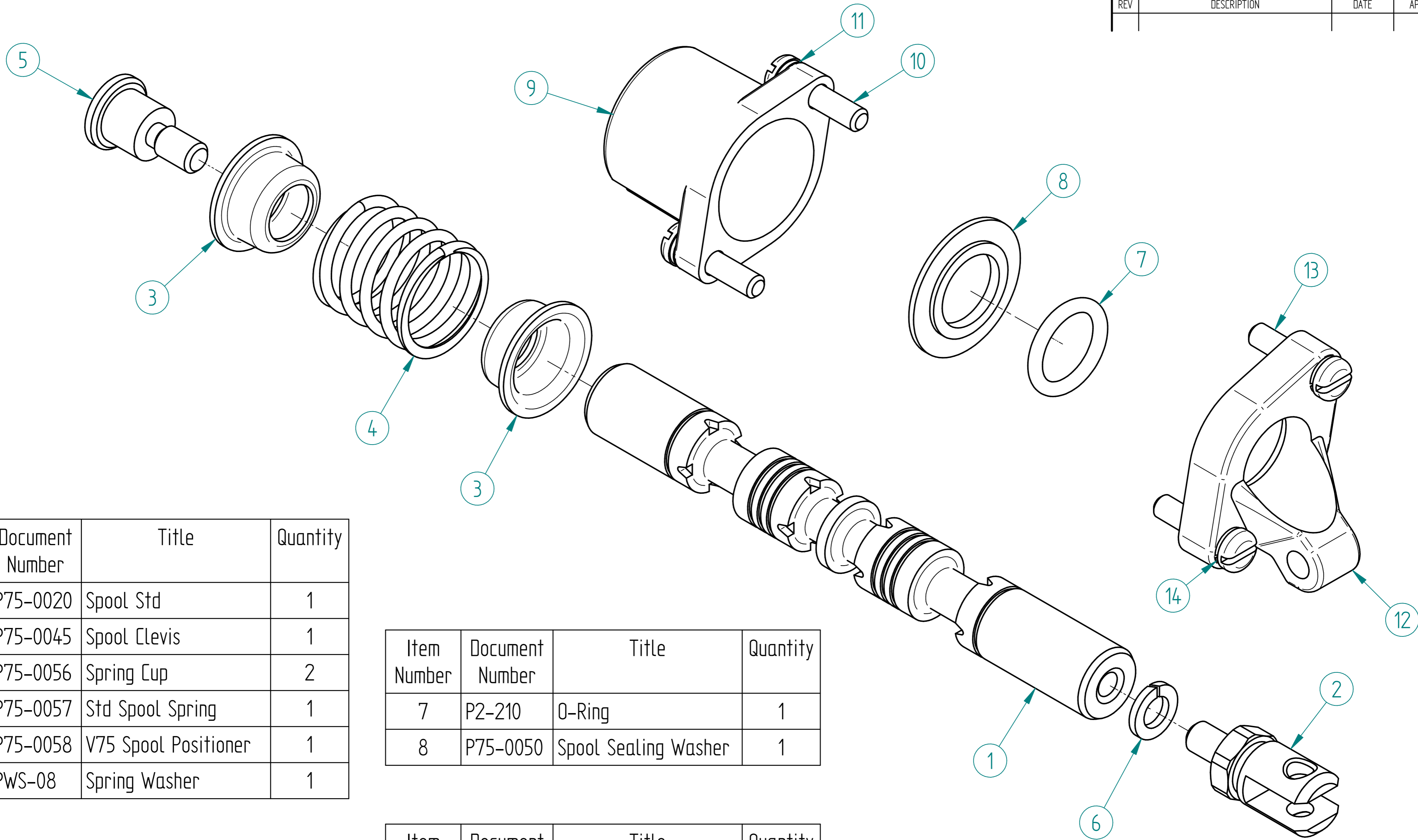

Item Number	Document Number	Title	Quantity
1	P75-0020	Spool Std	1
2	P75-0045	Spool Clevis	1
3	P75-0056	Spring Cup	2
4	P75-0057	Std Spool Spring	1
5	P75-0058	V75 Spool Positioner	1
6	PWS-08	Spring Washer	1

Item Number	Document Number	Title	Quantity
7	P2-210	O-Ring	1
8	P75-0050	Spool Sealing Washer	1

Item Number	Document Number	Title	Quantity
12	P75-0150	V75 Handle Bracket	1
13	PSM6-25	Screw C H	2
14	PWS-6	Spring Washer	2

Item Number	Document Number	Title	Quantity
9	P75-0055	Std Bonnet	1
10	PSM6-25	Screw C H	2
11	PWS-6	Spring Washer	2

NAME	DATE	PREMAC	
DRAWN: Dan	09/04/23	PRECISION MACHINE MANUFACTURERS (PTY)LTD.	
APPROVED		TITLE: V75 Std 4 Way	
MATERIAL		SIZE: A2	DWG NO: V75-CS-4WAY
TREATMENT		FILE NAME: Std 4 Way.dft	
UNLESS OTHERWISE SPECIFIED DIMENSIONS ARE IN MILLIMETERS		SCALE:	WEIGHT:
1 ST ANGLE		SHEET 3 OF 7	
2 PL ±0.02 3 PL ±0.005			

Item Number	Document Number	Title	Quantity	Item Number	Document Number	Title	Quantity
1	3-910	O-Ring	1	8	P2-016	O-Ring	1
2	P	O-Ring	1	9	P75-0121	Load Holding Spring	1
3	P150-0131	Relief Cap	1	10	P75-0122	Load Holding Check	1
4	P150-0132	Relief Poppet	1	11	P75-0130	Port Relief Housing	1
5	P150-0133	PTFE Seal	1	12	P8-015	Back Up	2
6	P150-0136	Relief Spring	1	13	P8-016	Back Up	1
7	P2-015	O-Ring	1				

REVISION HISTORY			
REV	DESCRIPTION	DATE	APPROVED

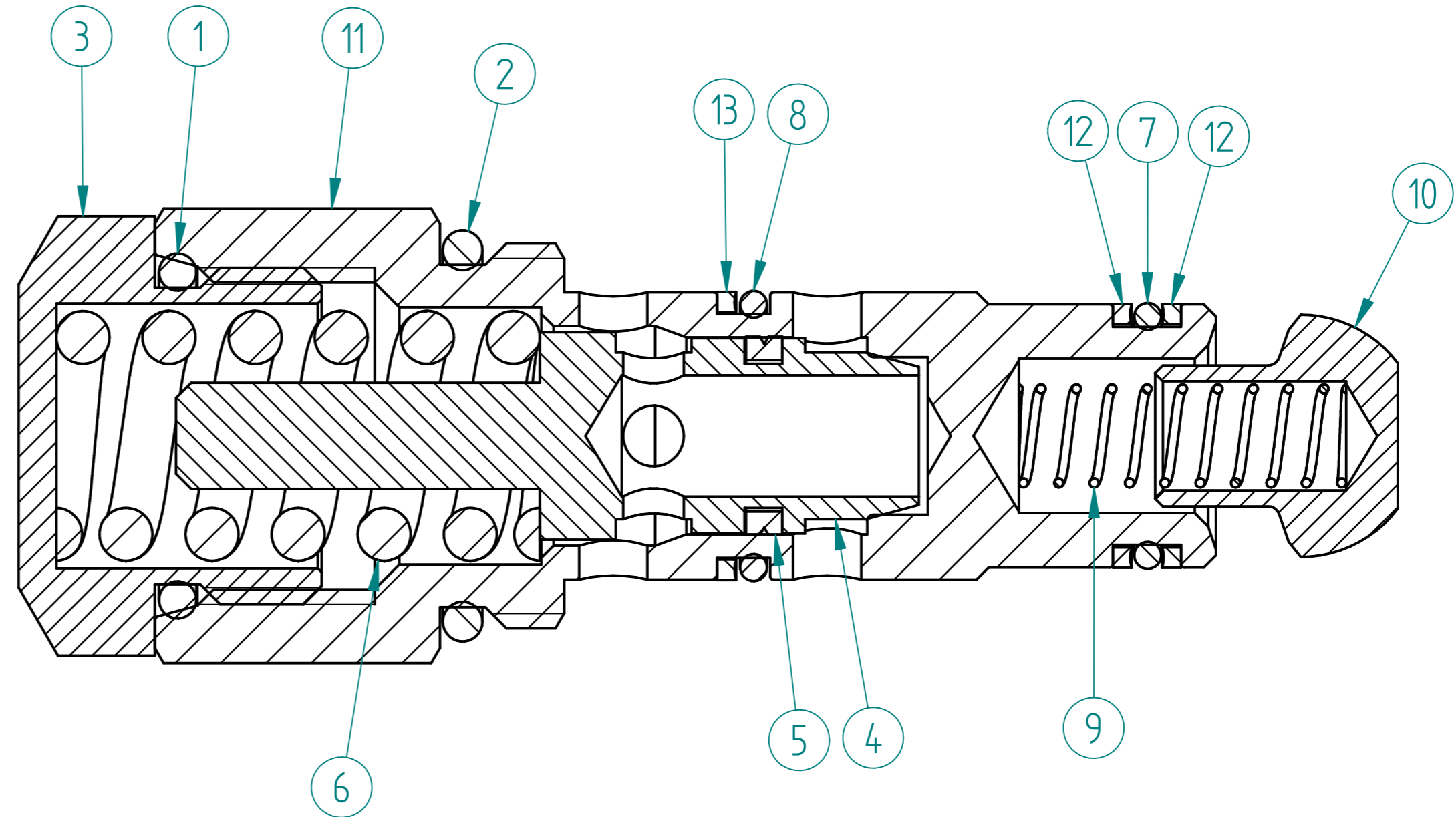
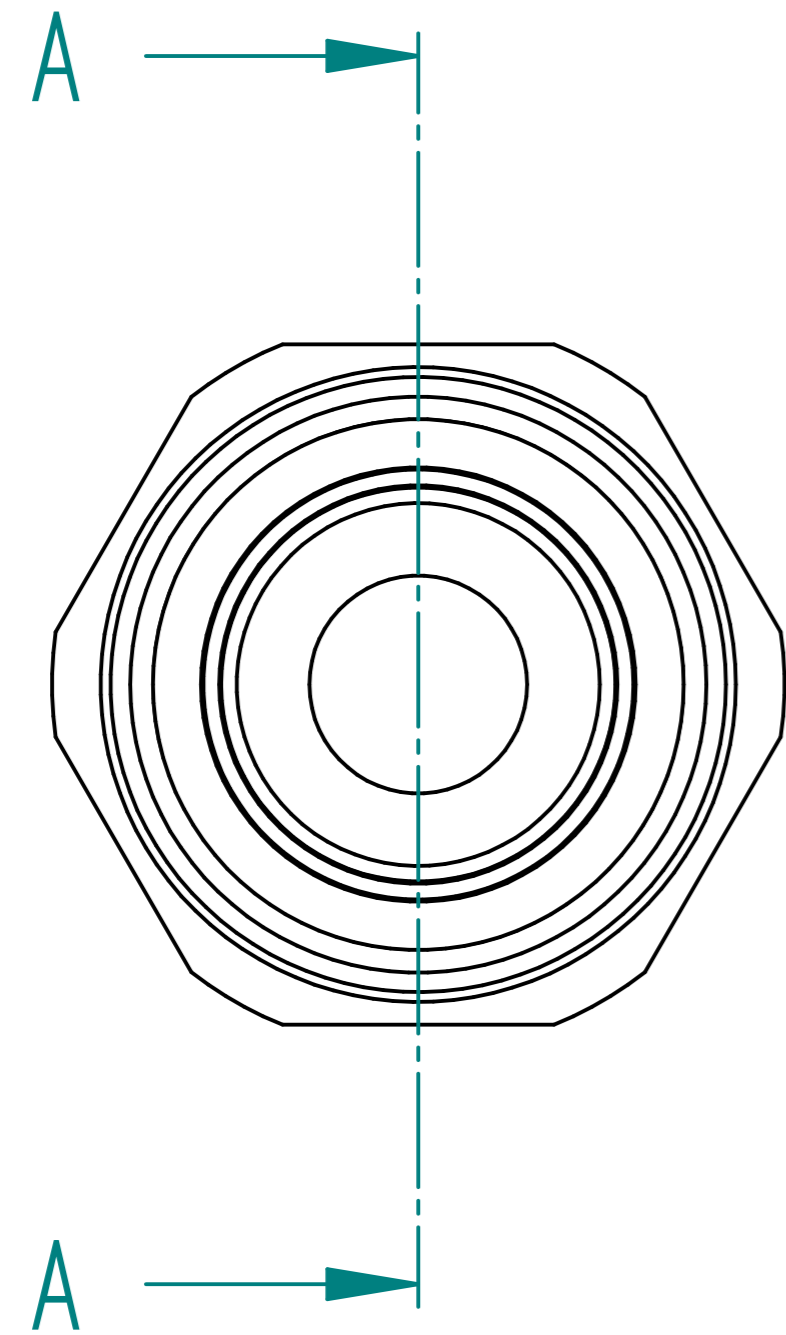

SECTION A-A

NAME	DATE	PREMAC	
DRAWN: Dan	09/04/23	PRECISION MACHINE MANUFACTURERS (PTY)LTD.	
APPROVED		TITLE: V75 Std 4 Way	
MATERIAL		SIZE: A2	DWG NO: V75-CS-4WAY
TREATMENT		FILE NAME: Std 4 Way.dft	REV
UNLESS OTHERWISE SPECIFIED DIMENSIONS ARE IN MILLIMETERS		SCALE:	WEIGHT:
ANGLES ±0.1°		SHEET 4 OF 7	
2 PL ±0.02 3 PL ±0.005			

Item Number	Document Number	Title	Quantity
1	P	O-Ring	1
2	P2-015	O-Ring	1
3	P2-016	O-Ring	1
4	P75-0121	Load Holding Spring	1
5	P75-0122	Load Holding Check	1
6	P75-0125	Port Relief Plug	1
7	P8-015	Back Up	2
8	P8-016	Back Up	1

REVISION HISTORY			
REV	DESCRIPTION	DATE	APPROVED

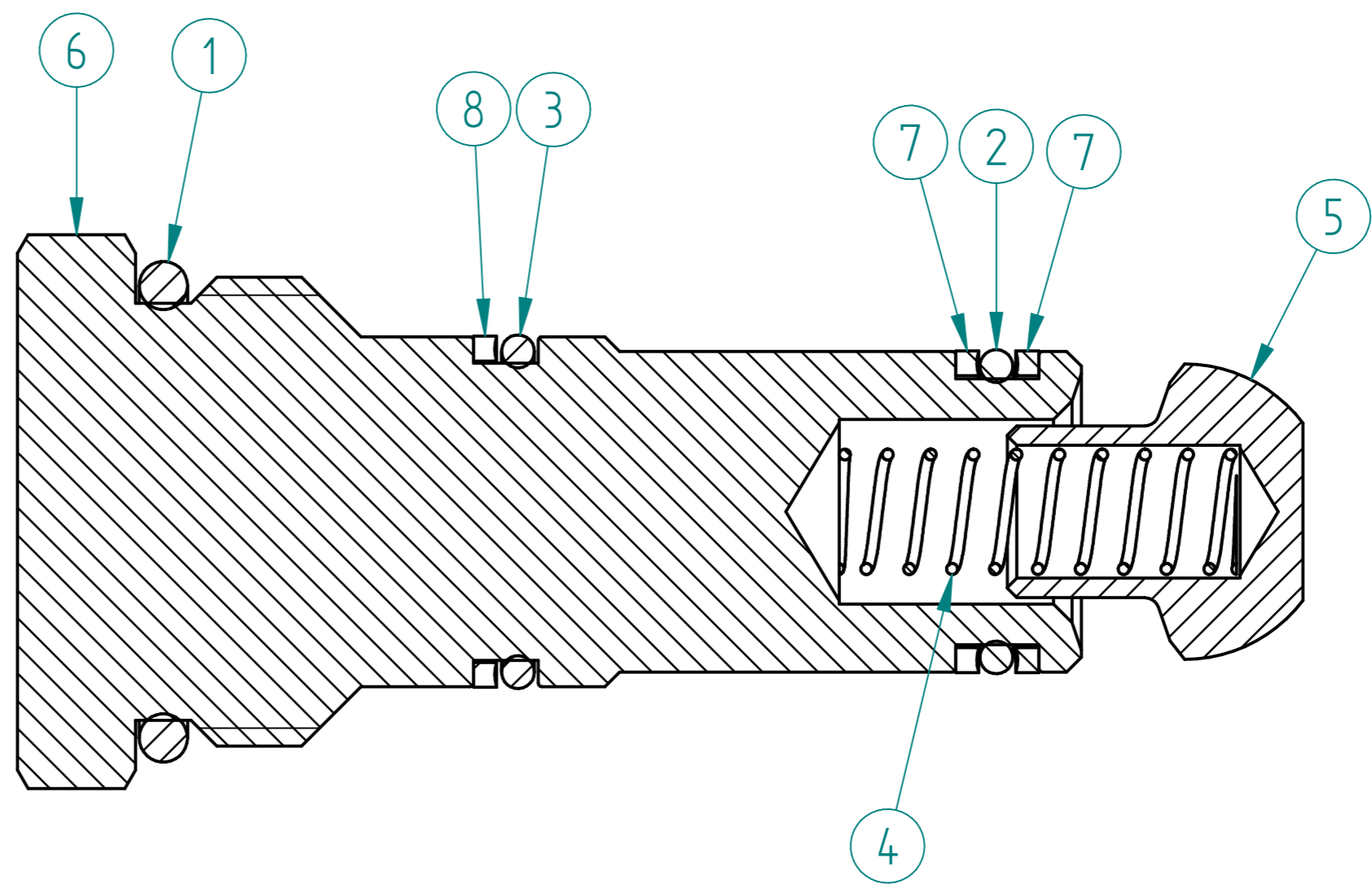
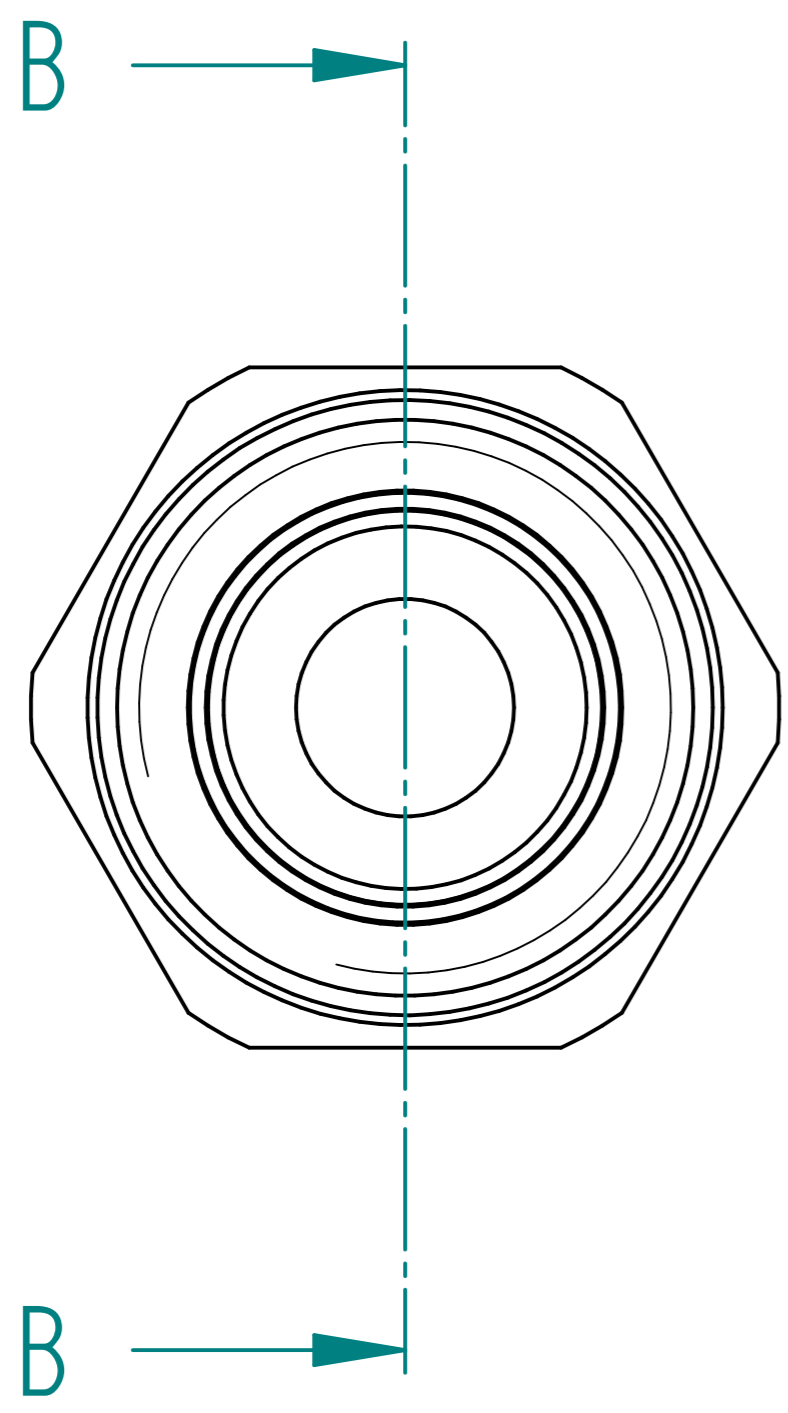

SECTION B-B

NAME	DATE	PREMAC	
DRAWN: Dan	09/04/23	PRECISION MACHINE MANUFACTURERS (PTY)LTD.	
APPROVED		TITLE: V75 Std 4 Way	
MATERIAL		SIZE: A2	DWG NO: V75-CS-4WAY
TREATMENT		FILE NAME: Std 4 Way.dft	REV
UNLESS OTHERWISE SPECIFIED DIMENSIONS ARE IN MILLIMETERS		SCALE:	WEIGHT:
1st ANGLE		2 PL ±0.02	3 PL ±0.005
ANGLES ±0.1°		SHEET 5 OF 7	

REVISION HISTORY			
REV	DESCRIPTION	DATE	APPROVED

Item Number	Document Number	Title	Quantity
1*			1
2	M10	Nut	1
3	P150-0154	Handle Shaft	1
4	P150-0155	Handle knob	1
5*	P150-0156	Clevice Pin	1
6	P75-0153	V75 Handle Base	1

Item Number	Document Number	Title	Quantity
7*			2
8	P150-0157	U Link	1
9	P150-0158	U Link Plate	1

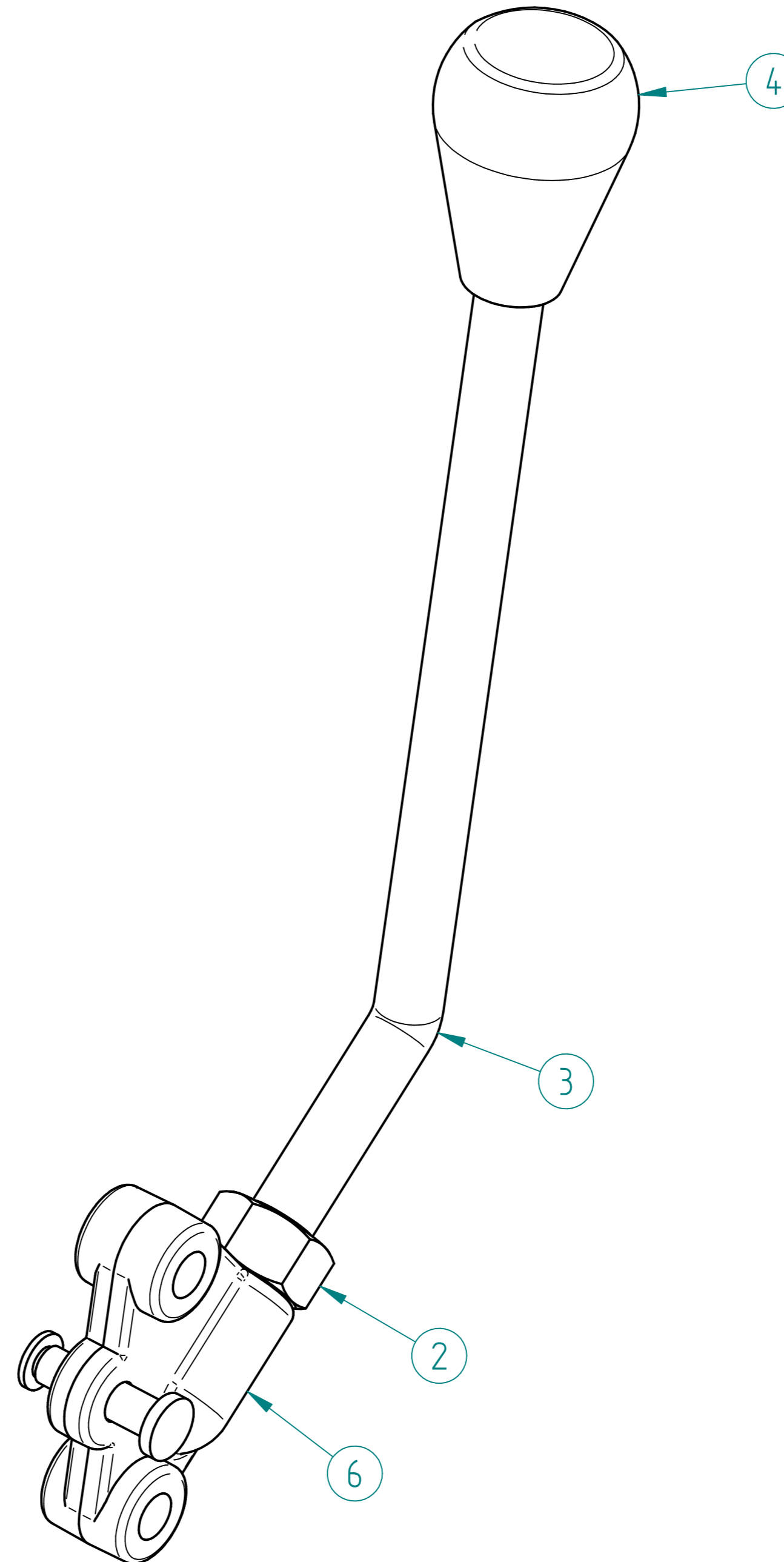
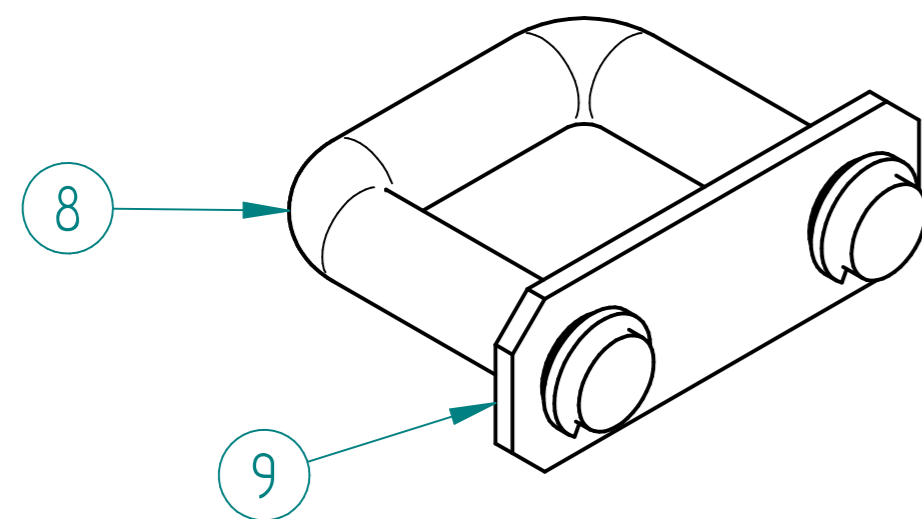

	NAME	DATE	PREMAC	
DRAWN	Dan	09/04/23	PRECISION MACHINE MANUFACTURERS (PTY)LTD.	
APPROVED			TITLE	
MATERIAL			V75 Std 4 Way	
TREATMENT			SIZE	DWG NO
UNLESS OTHERWISE SPECIFIED DIMENSIONS ARE IN MILLIMETERS ANGLES ±0.1°			A2	V75-CS-4WAY
			SCALE:	WEIGHT:
1st ANGLE 			FILE NAME: Std 4 Way.dft	REV
2 PL ±0.02 3 PL ±0.005			SCALE:	SHEET 6 OF 7

Item Number	Document Number	Title	Quantity	Item Number	Document Number	Title	Quantity
1			1	20	P75-0058	V75 Spool Positioner	1
2			3	21	P75-0121	Load Holding Spring	2
3	2-116	O-Ring	1	22	P75-0122	Load Holding Check	2
4	M10	Nut	1	23	P75-0125	Port Relief Plug	2
5	P	O-Ring	5	24	P75-0150	V75 Handle Bracket	1
6	P150-0154	Handle Shaft	1	25	P75-0153	V75 Handle Base	1
7	P150-0155	Handle knob	1	26	P8-015	Back Up	4
8	P150-0156	Clevice Pin	1	27	P8-016	Back Up	2
9	P150-0157	U Link	1	28	PSM6-25	Screw C H	4
10	P150-0158	U Link Plate	1	29	PWS-08	Spring Washer	1
11	P2-015	O-Ring	2	30	PWS-6	Spring Washer	4
12	P2-016	O-Ring	2				
13	P2-210	O-Ring	2				
14	P75-0020	Spool Std	1				
15	P75-0045	Spool Clevis	1				
16	P75-0050	Spool Sealing Washer	2				
17	P75-0055	Std Bonnet	1				
18	P75-0056	Spring Cup	2				
19	P75-0057	Std Spool Spring	1				

REVISION HISTORY			
REV	DESCRIPTION	DATE	APPROVED

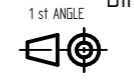
DRAWN	Dan	09/04/23	PREMAC PRECISION MACHINE MANUFACTURERS (PTY)LTD.	
APPROVED				
MATERIAL			TITLE V75 Std 4 Way	
TREATMENT			SIZE A2	DWG NO V75-CS-4WAY
UNLESS OTHERWISE SPECIFIED DIMENSIONS ARE IN MILLIMETERS ANGLES ±0.1°			FILE NAME: Std 4 Way.dft	REV
1st ANGLE 			SCALE:	WEIGHT:
2 PL ±0.02 3 PL ±0.005			SHEET 7 OF 7	