

REVISION HISTORY			
REV	DESCRIPTION	DATE	APPROVED

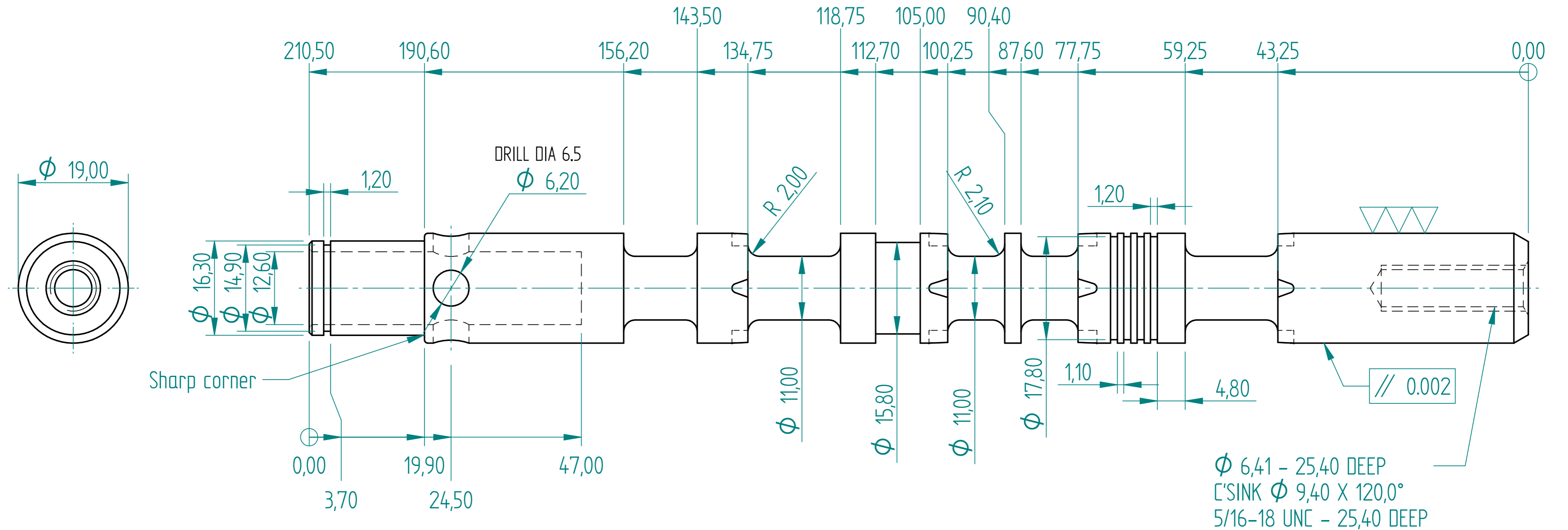

PRE-TURN TO DIA 19.1  
 PRE-GRIND TO DIA 18.9  
 HARD CHROME TO DIA 19.2  
 FINAL GRIND TO DIA 19.00

	NAME	DATE	PREMAC	
DRAWN	Dan	09/04/23	PRECISION MACHINE MANUFACTURERS (PTY)LTD.	
APPROVED			TITLE	
MATERIAL	EN-1A		Float Spool	
TREATMENT	Hard Chrome		SIZE	DWG NO
UNLESS OTHERWISE SPECIFIED DIMENSIONS ARE IN MILLIMETERS			A2	
1 <sup>ST</sup> ANGLE			FILE NAME: Float Spool.dft	REV
2 PL $\pm 0.02$ 3 PL $\pm 0.005$			SCALE:	WEIGHT:
				SHEET 1 OF 2

REVISION HISTORY			
REV	DESCRIPTION	DATE	APPROVED

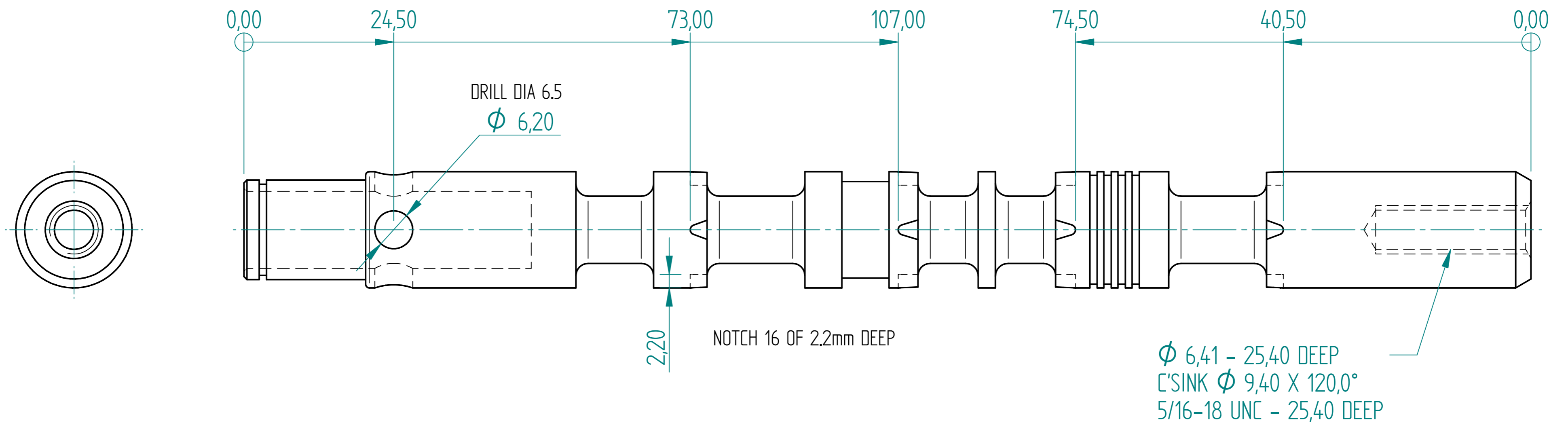

PRE-TURN TO DIA 19.1  
 PRE-GRIND TO DIA 18.9  
 HARD CHROME TO DIA 19.2  
 FINAL GRIND TO DIA 19.00

	NAME	DATE	PREMAC	
DRAWN	Dan	09/04/23	PRECISION MACHINE MANUFACTURERS (PTY)LTD.	
APPROVED			TITLE	
MATERIAL			Float Spool	
TREATMENT			SIZE	DWG NO
UNLESS OTHERWISE SPECIFIED DIMENSIONS ARE IN MILLIMETERS			A2	REV
1 <sup>ST</sup> ANGLE			FILE NAME: Float Spool.dft	
2 PL ±0.02 3 PL ±0.005			SCALE:	WEIGHT: SHEET 2 OF 2