

REVISION HISTORY			
REV	DESCRIPTION	DATE	APPROVED

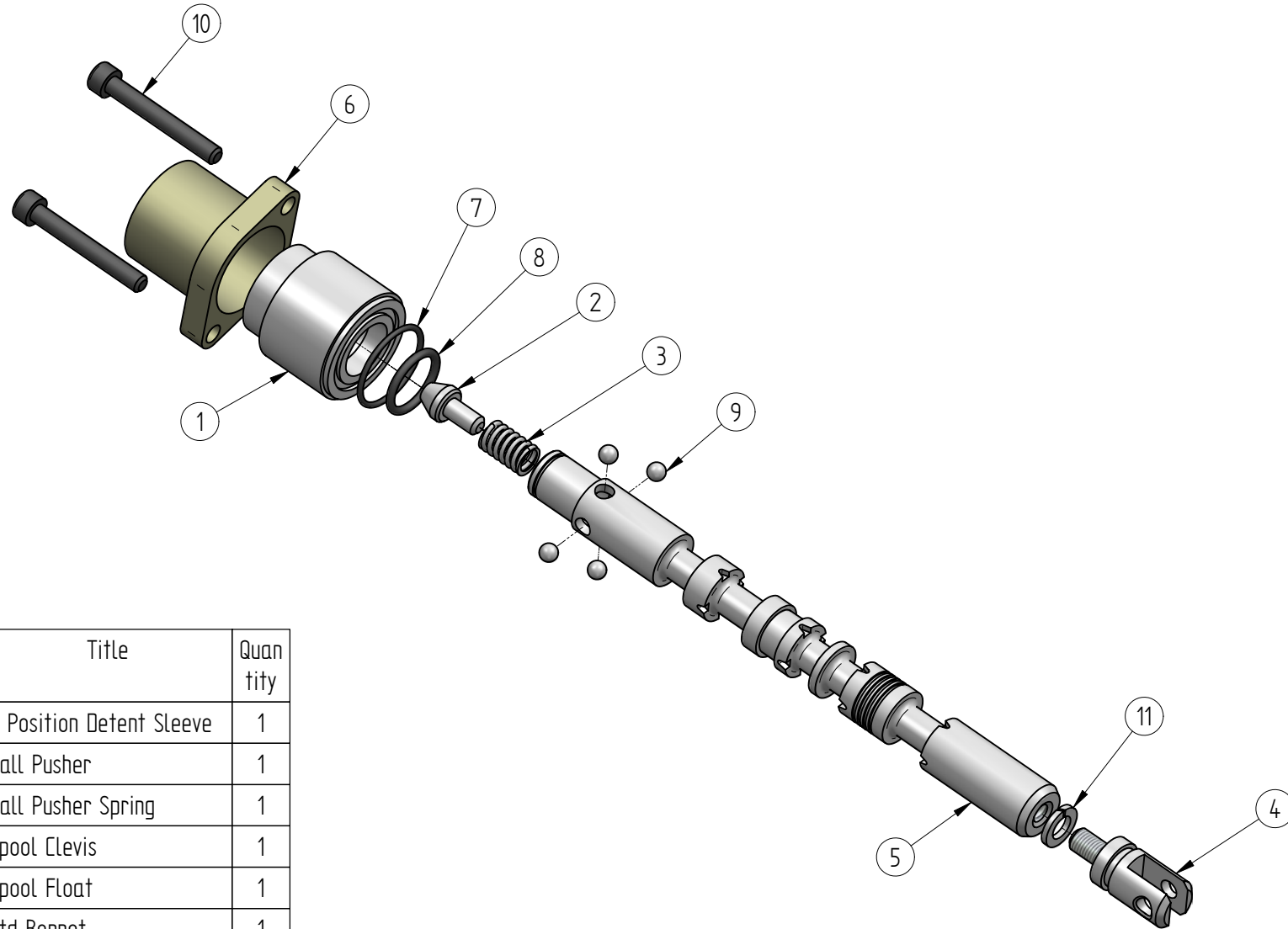

Item Number	Document Number	Title	Quantity
1		4 Position Detent Sleeve	1
2		Ball Pusher	1
3		Ball Pusher Spring	1
4		Spool Clevis	1
5		Spool Float	1
6		Std Bonnet	1
7	2-023	O-Ring	1
8	2-116	O-Ring	1
9	Dia 6	Ball	4
10	M6-45	Cap Screw	2
11	M8	Spring Washer	1

NAME	DATE	PREMAC	
DRAWN Dan	06/20/05	PRECISION MACHINE MANUFACTURERS (PTY)LTD.	
APPROVED		TITLE Float Spool 4 Position Detent Sleeve	
MATERIAL		FILE NAME: Float Spool 4 Position Detent.dft	
TREATMENT		SIZE A2	DWG NO
UNLESS OTHERWISE SPECIFIED DIMENSIONS ARE IN MILLIMETERS ANGLES ±0.1°		SCALE:	WEIGHT:
2 PL ±0.02 3 PL ±0.005		SHEET 2 OF 4	