

REVISION HISTORY			
REV	DESCRIPTION	DATE	APPROVED

INLET PORT, FROM PUMP

OUTLET PORT, TO TANK

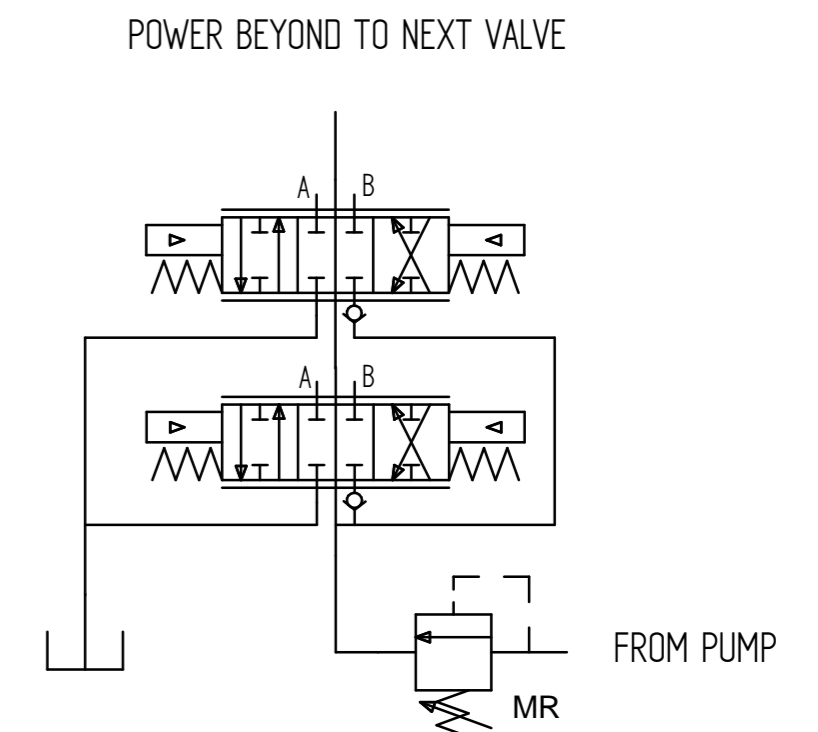
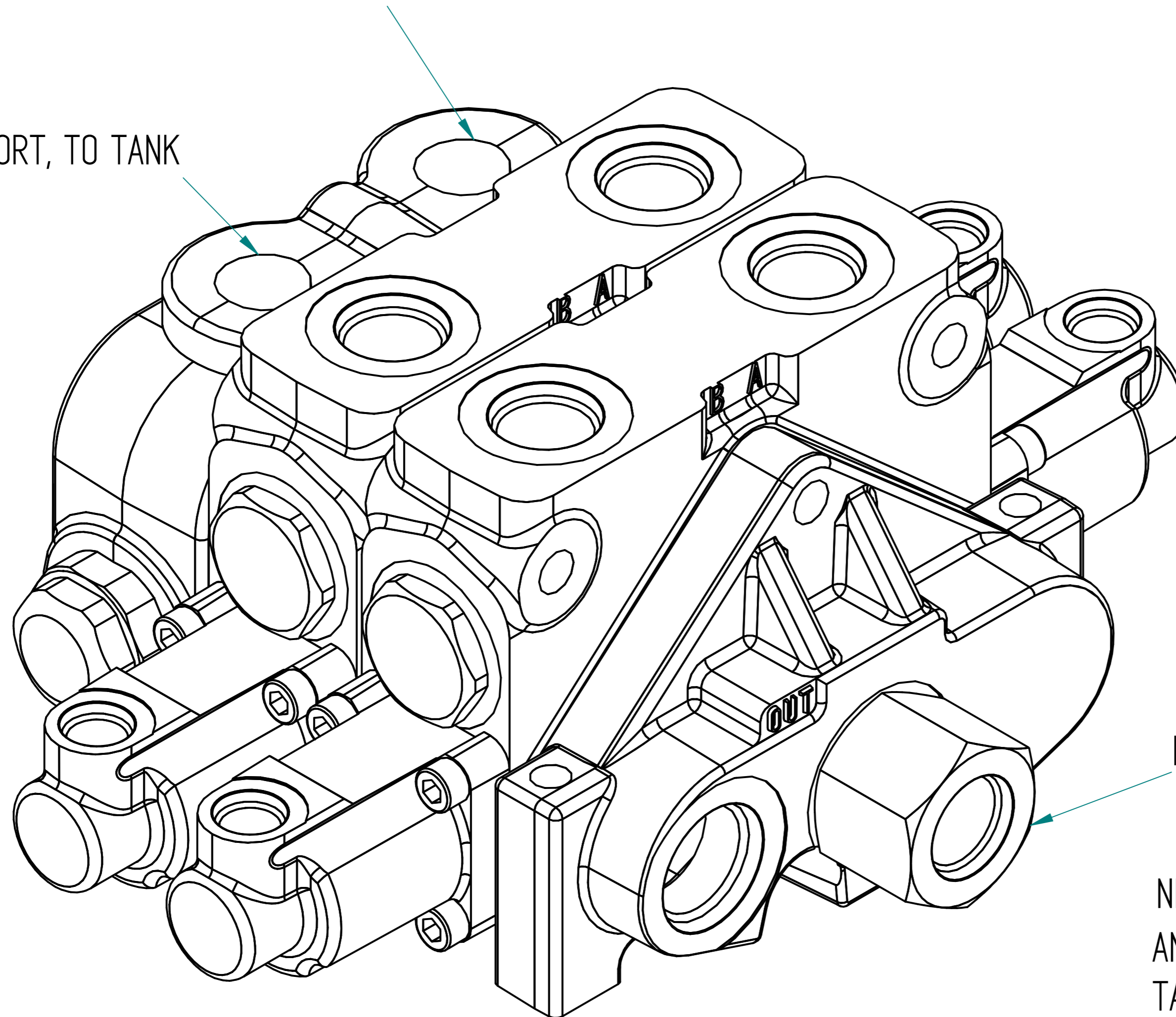

POWER BEYOND, TO NEXT VALVE

NB THIS SLEEVE MUST NOT BE REMOVED
AND THIS VALVE MUST HAVE ITS OWN
TANK RETURN LINE AS INDICATED

	NAME	DATE	PREMAC	
DRAWN	Dan	09/04/23	PRECISION MACHINE MANUFACTURERS (PTY)LTD.	
APPROVED			TITLE	V75- 2HRTY
MATERIAL			SIZE	A2
TREATMENT			DWG NO	
UNLESS OTHERWISE SPECIFIED DIMENSIONS ARE IN MILLIMETERS			FILE NAME:	2 Bank HR Y.dft
ANGLES ±0.1°			SCALE:	
2 PL ±0.02 3 PL ±0.005			WEIGHT:	
1st ANGLE			SHEET 1 OF 1	