

REVISION HISTORY			
REV	DESCRIPTION	DATE	APPROVED

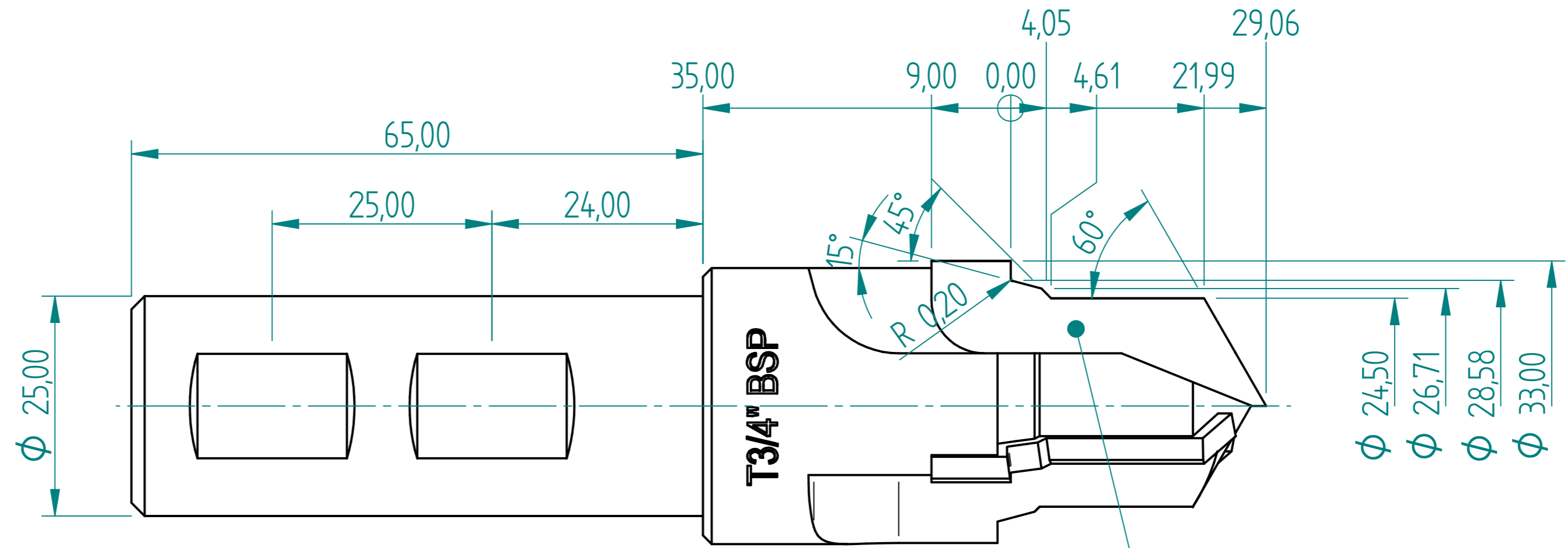

Brazed Carbide Strip 3 of 1 Strip Centre Cutting

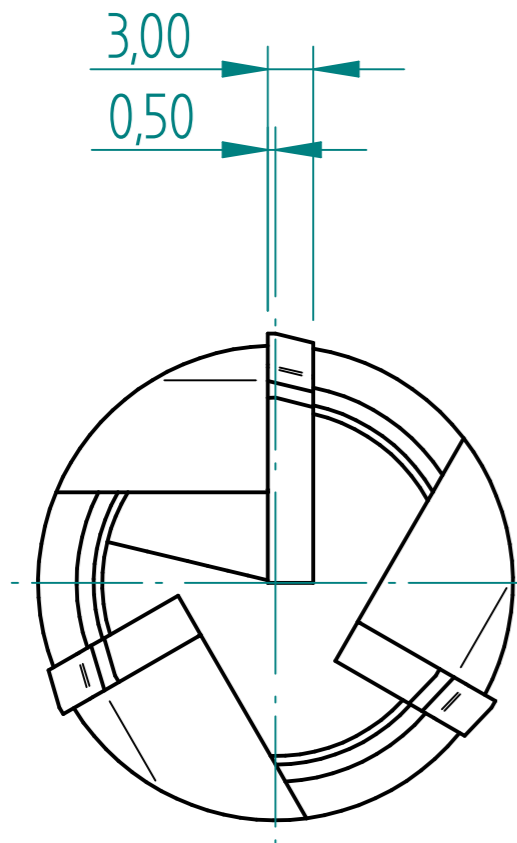
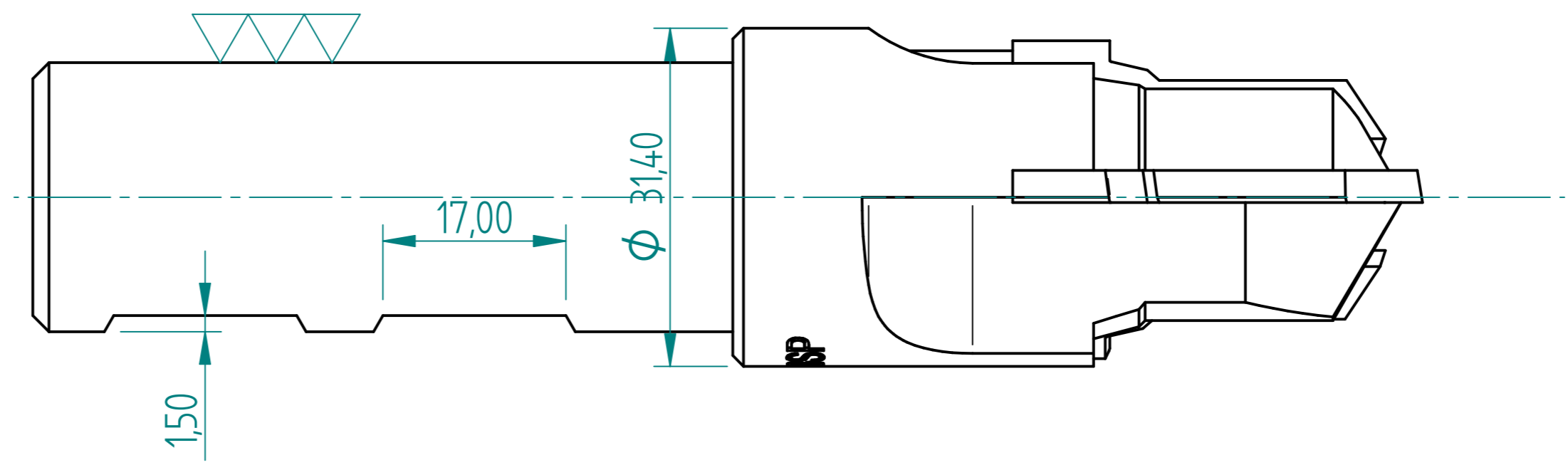

Tank 3/4" BSPP PORT BAR

	NAME	DATE	AGRIGEL		
DRAWN	Dan	05/03/25			
APPROVED			TITLE Tank 3-4 BSP Bar		
MATERIAL					
TREATMENT			SIZE A4	DWG NO	REV
UNLESS OTHERWISE SPECIFIED DIMENSIONS ARE IN MILLIMETERS			FILE NAME: Tank 3-4 BSP Bar.dft		
1 st ANGLE 2 PL ±0.02 3 PL ±0.005			SCALE:	WEIGHT:	SHEET 1 OF 2

REVISION HISTORY			
REV	DESCRIPTION	DATE	APPROVED

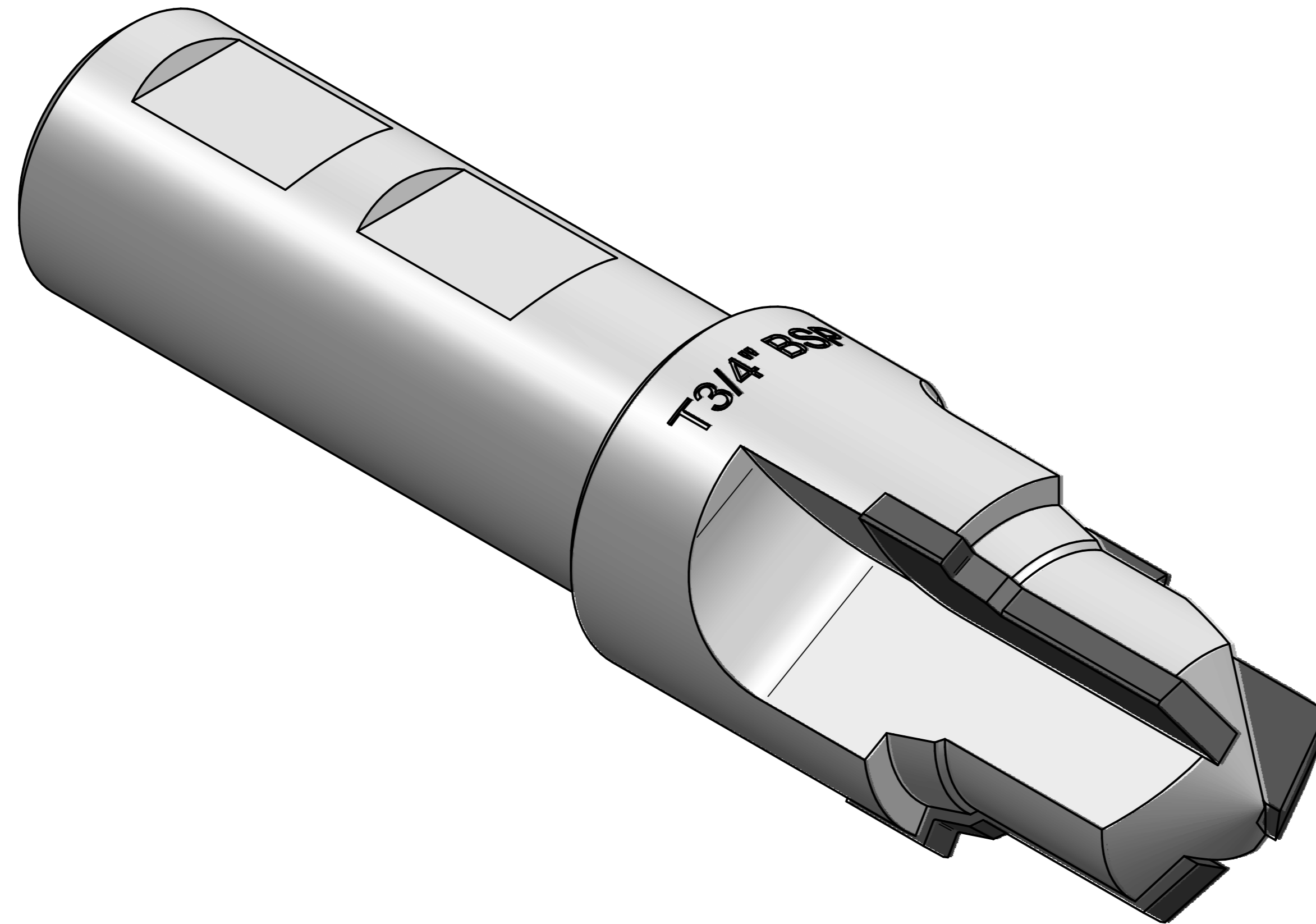

	NAME	DATE	AGRIGEL		
DRAWN	Dan	05/03/25			
APPROVED					
MATERIAL					
TREATMENT			TITLE Tank 3-4 BSP Bar		
UNLESS OTHERWISE SPECIFIED DIMENSIONS ARE IN MILLIMETERS			SIZE A4	DWG NO	REV
1 st ANGLE 2 PL ±0.02 3 PL ±0.005			FILE NAME: Tank 3-4 BSP Bar.dft		
			SCALE:	WEIGHT:	SHEET 2 OF 2