

REVISION HISTORY			
REV	DESCRIPTION	DATE	APPROVED

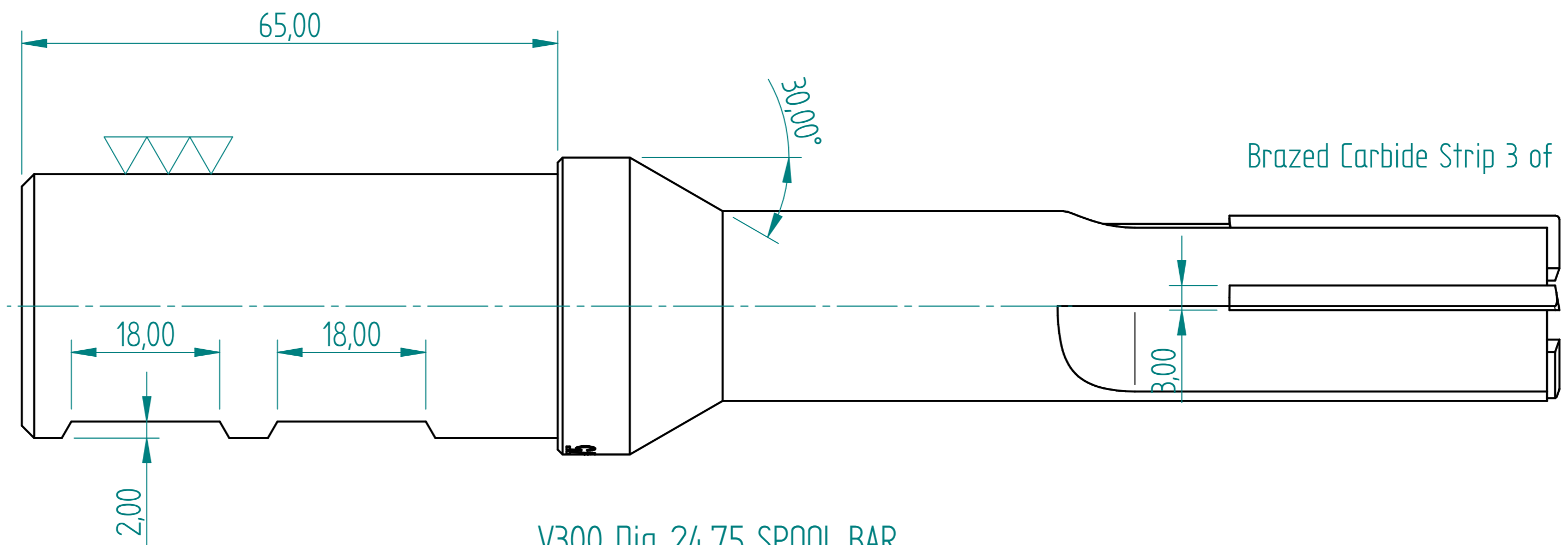
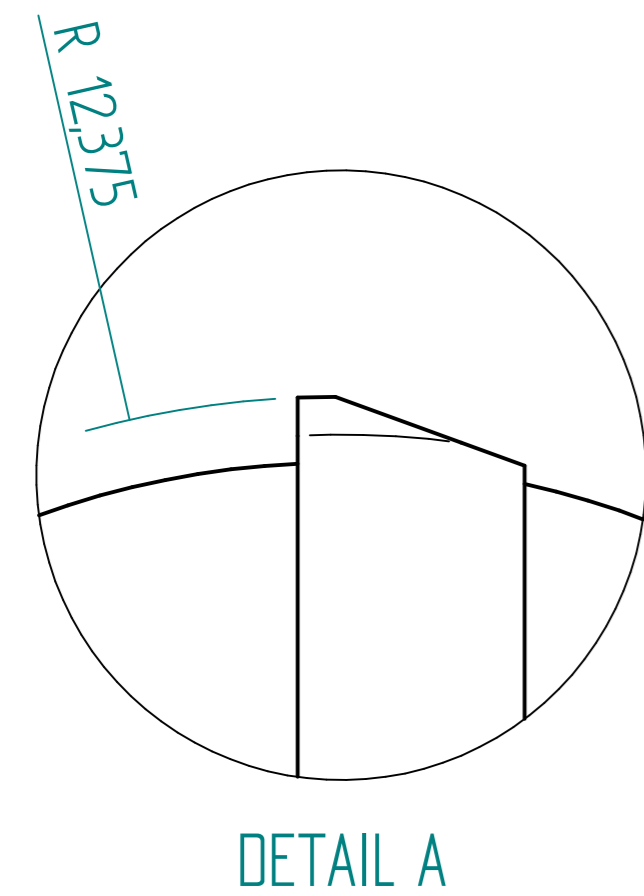
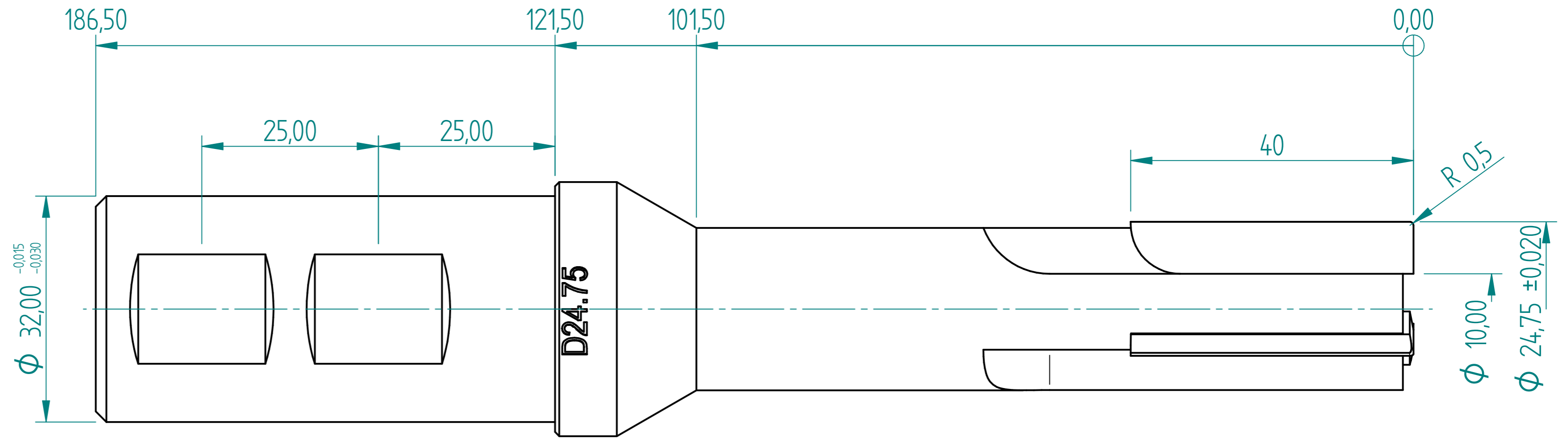
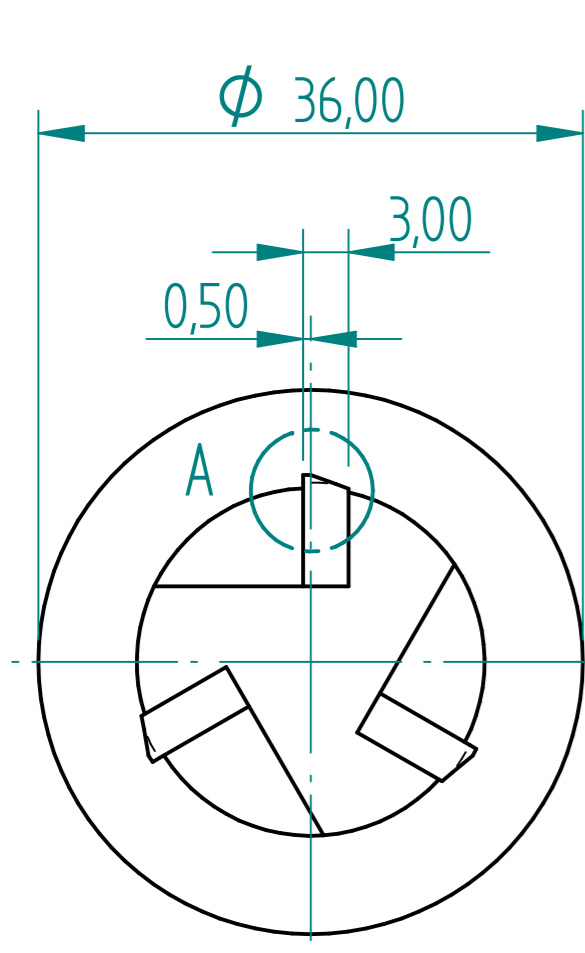

Brazed Carbide Strip 3 of

V300 Dia 24.75 SPOOL BAR
Cutting Cast Iron

	NAME	DATE	PREMAC	
DRAWN	Dan	04/23/25		
APPROVED			TITLE	
MATERIAL			V300 Dia 24.75 Spool Bar	
TREATMENT			SIZE	DWG NO
UNLESS OTHERWISE SPECIFIED DIMENSIONS ARE IN MILLIMETERS			A4	
1 ST ANGLE			FILE NAME: Dia 24.75 Spool Bar.dft	REV
2 PL ±0.02 3 PL ±0.005			SCALE:	WEIGHT:
			SHEET 1 OF 2	

REVISION HISTORY			
REV	DESCRIPTION	DATE	APPROVED

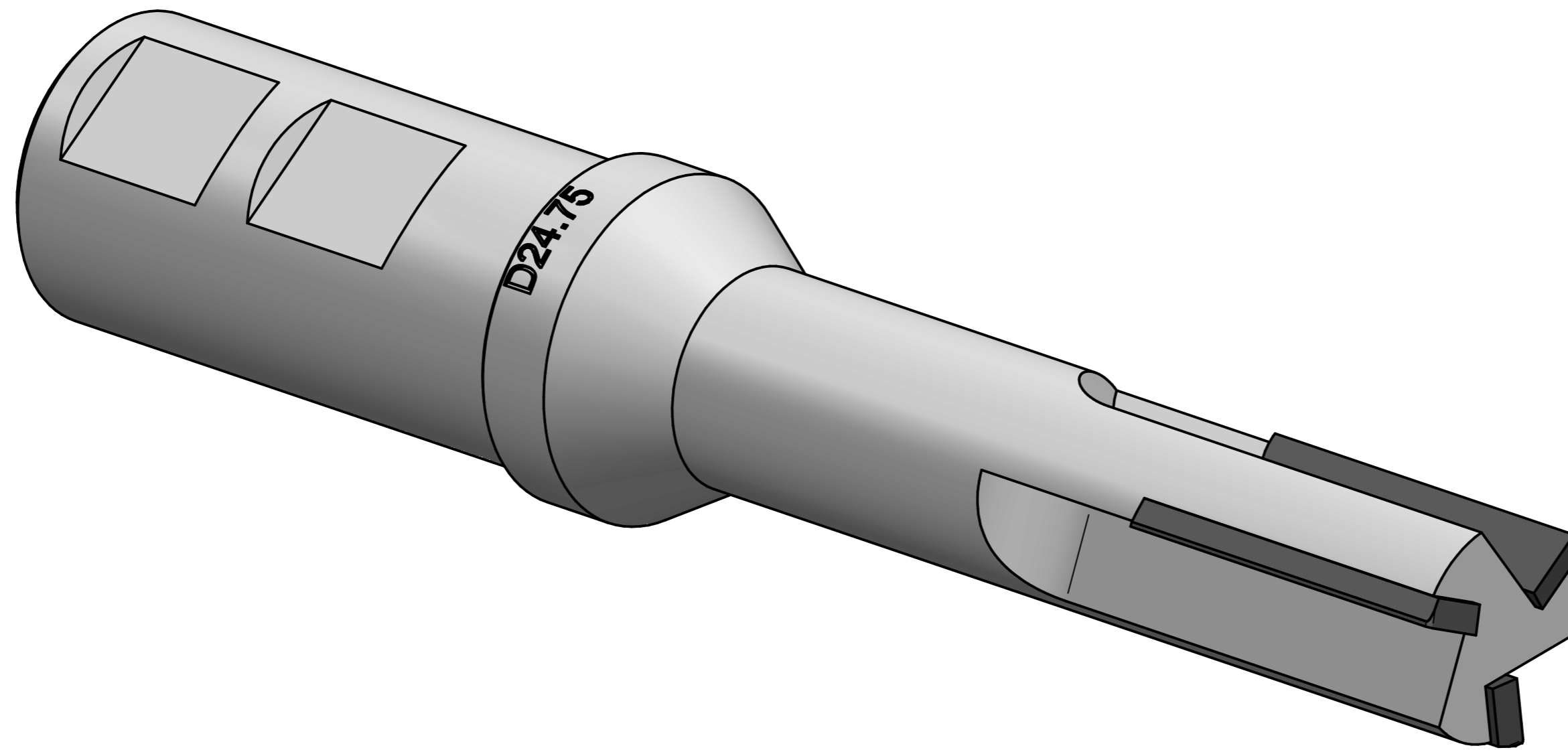

V300 Dia 24.75 SPOOL BAR

	NAME	DATE	PREMAC	
DRAWN	Dan	04/23/25		
APPROVED				
MATERIAL				
TREATMENT			TITLE	
			V300 Dia 24.75 Spool Bar	
UNLESS OTHERWISE SPECIFIED DIMENSIONS ARE IN MILLIMETERS			SIZE A4	DWG NO
1 ST ANGLE 			FILE NAME: Dia 24.75 Spool Bar.dft	REV
2 PL ±0.02 3 PL ±0.005			SCALE:	WEIGHT:
			SHEET 2 OF 2	