

REVISION HISTORY			
REV	DESCRIPTION	DATE	APPROVED

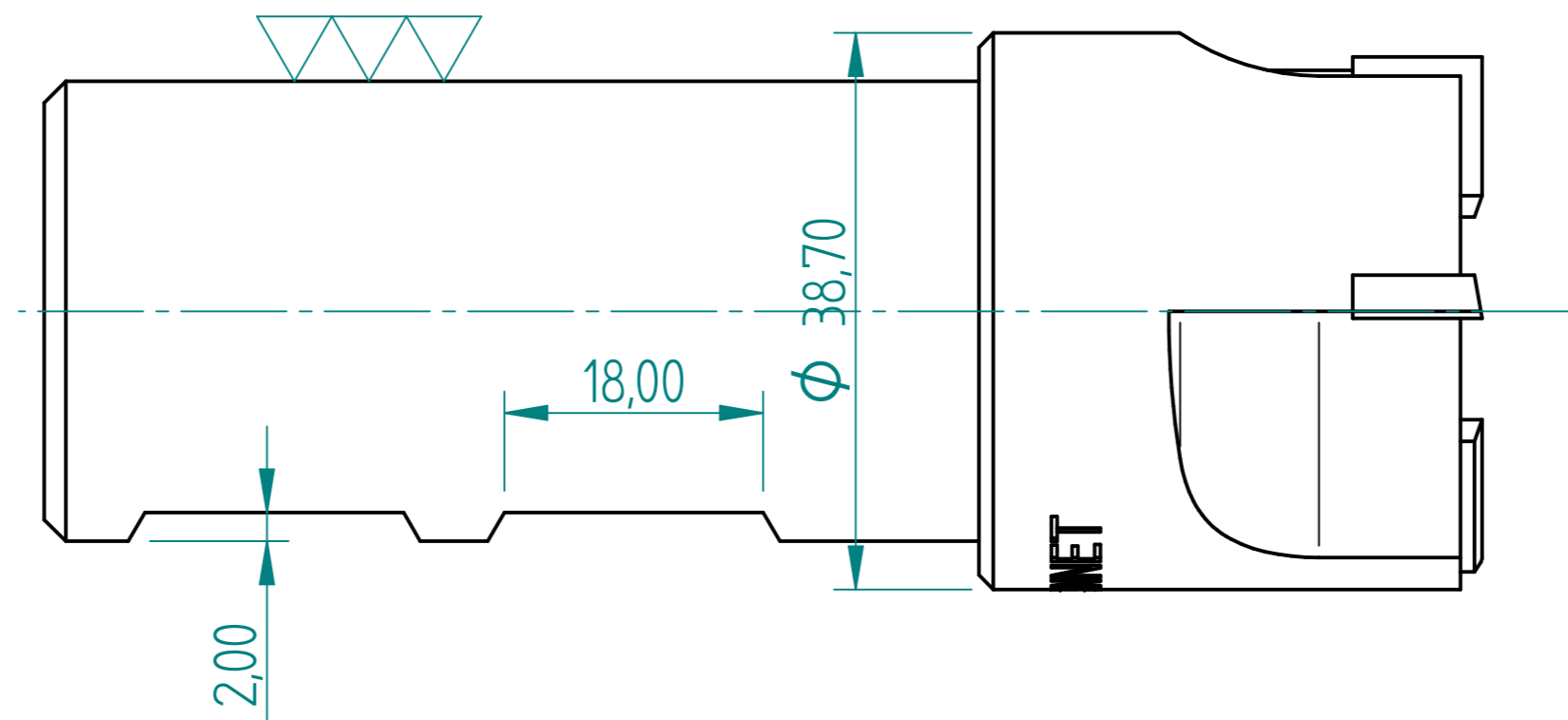
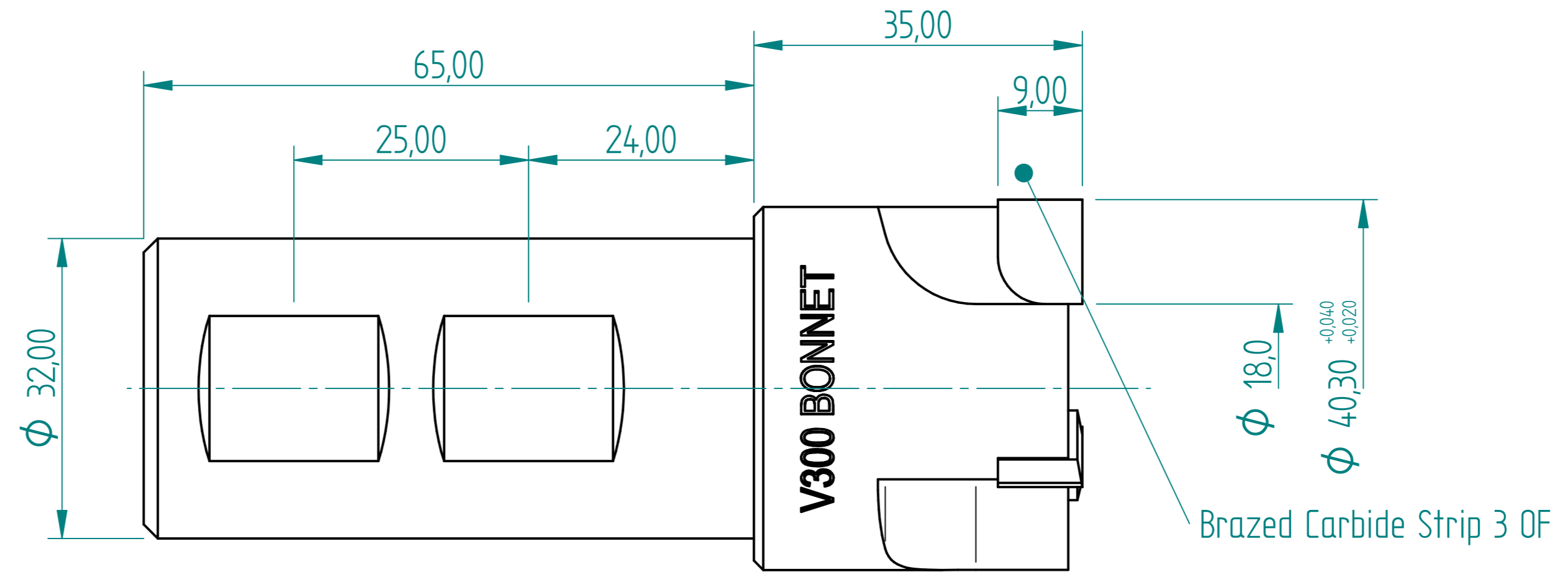
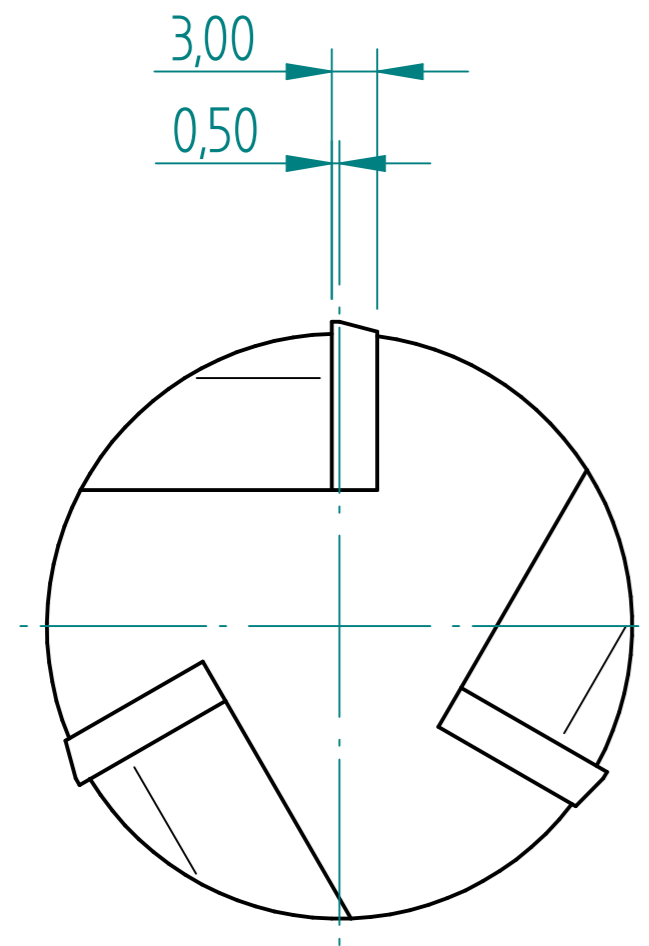

V300 SPOOL SEALING BAR

	NAME	DATE	AGRIGEL		
DRAWN	Dan	05/03/25			
APPROVED			TITLE V300 Bonnet Bar		
MATERIAL					
TREATMENT			SIZE A4	DWG NO	REV
UNLESS OTHERWISE SPECIFIED DIMENSIONS ARE IN MILLIMETERS			FILE NAME: V300 Bonnet Bar.dft		
1st ANGLE ANGLES ±0.1°			SCALE:	WEIGHT:	SHEET 1 OF 2
2 PL ±0.02 3 PL ±0.005					

REVISION HISTORY			
REV	DESCRIPTION	DATE	APPROVED

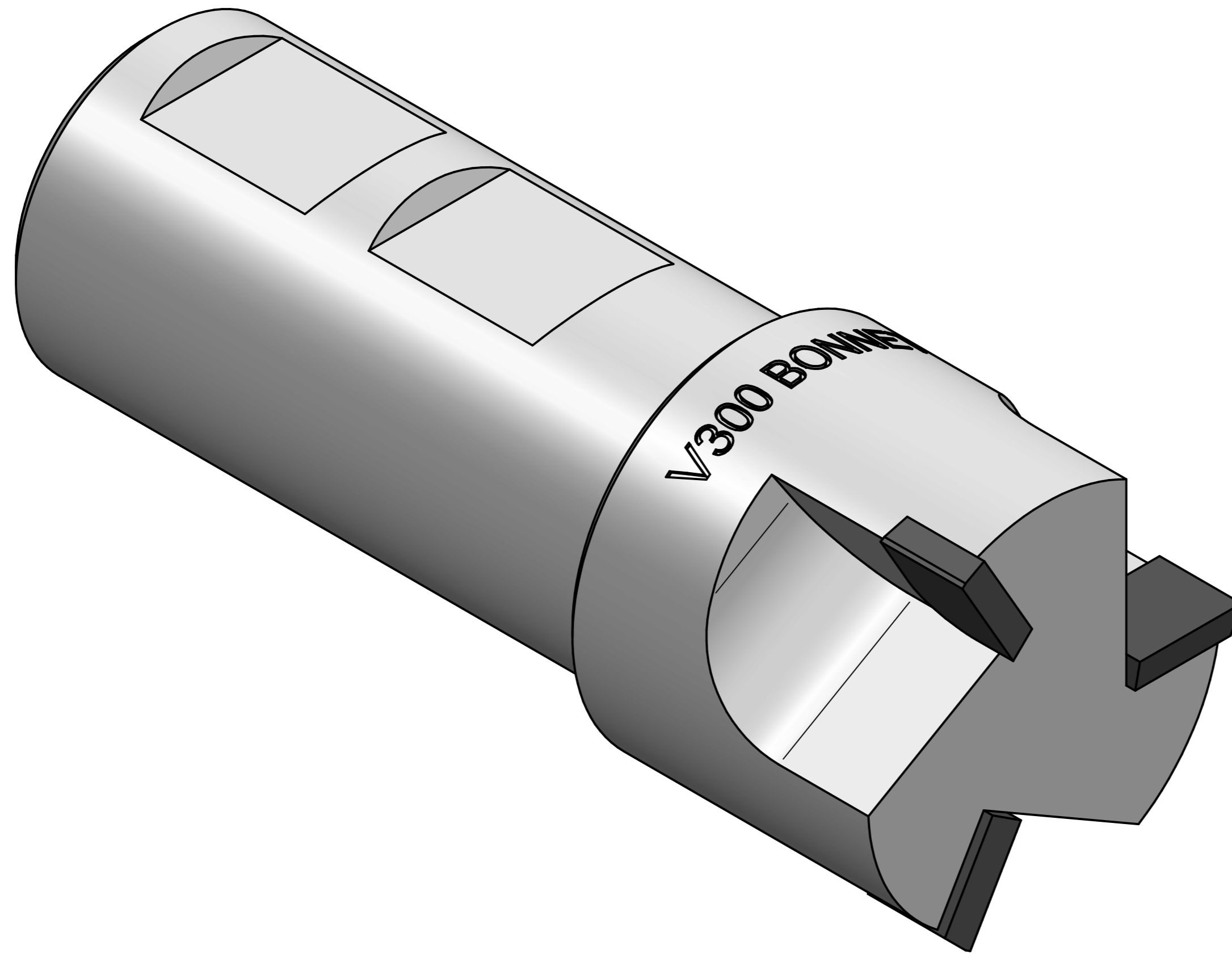

	NAME	DATE	AGRIGEL		
DRAWN	Dan	05/03/25			
APPROVED					
MATERIAL					
TREATMENT			TITLE V300 Bonnet Bar		
UNLESS OTHERWISE SPECIFIED DIMENSIONS ARE IN MILLIMETERS			SIZE A4	DWG NO	REV
1 st ANGLE  2 PL ±0.02 3 PL ±0.005			FILE NAME: V300 Bonnet Bar.dft		
			SCALE:	WEIGHT:	SHEET 2 OF 2