

REVISION HISTORY			
REV	DESCRIPTION	DATE	APPROVED

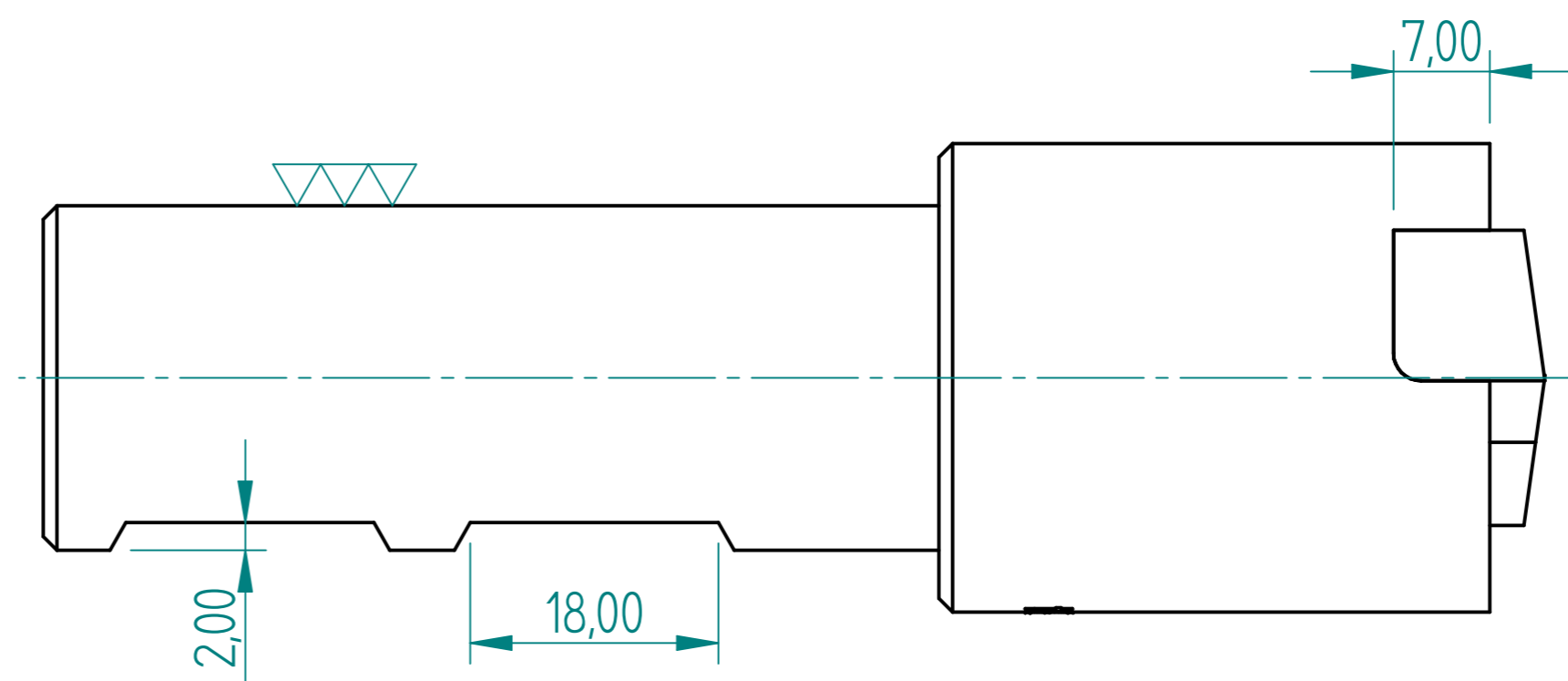
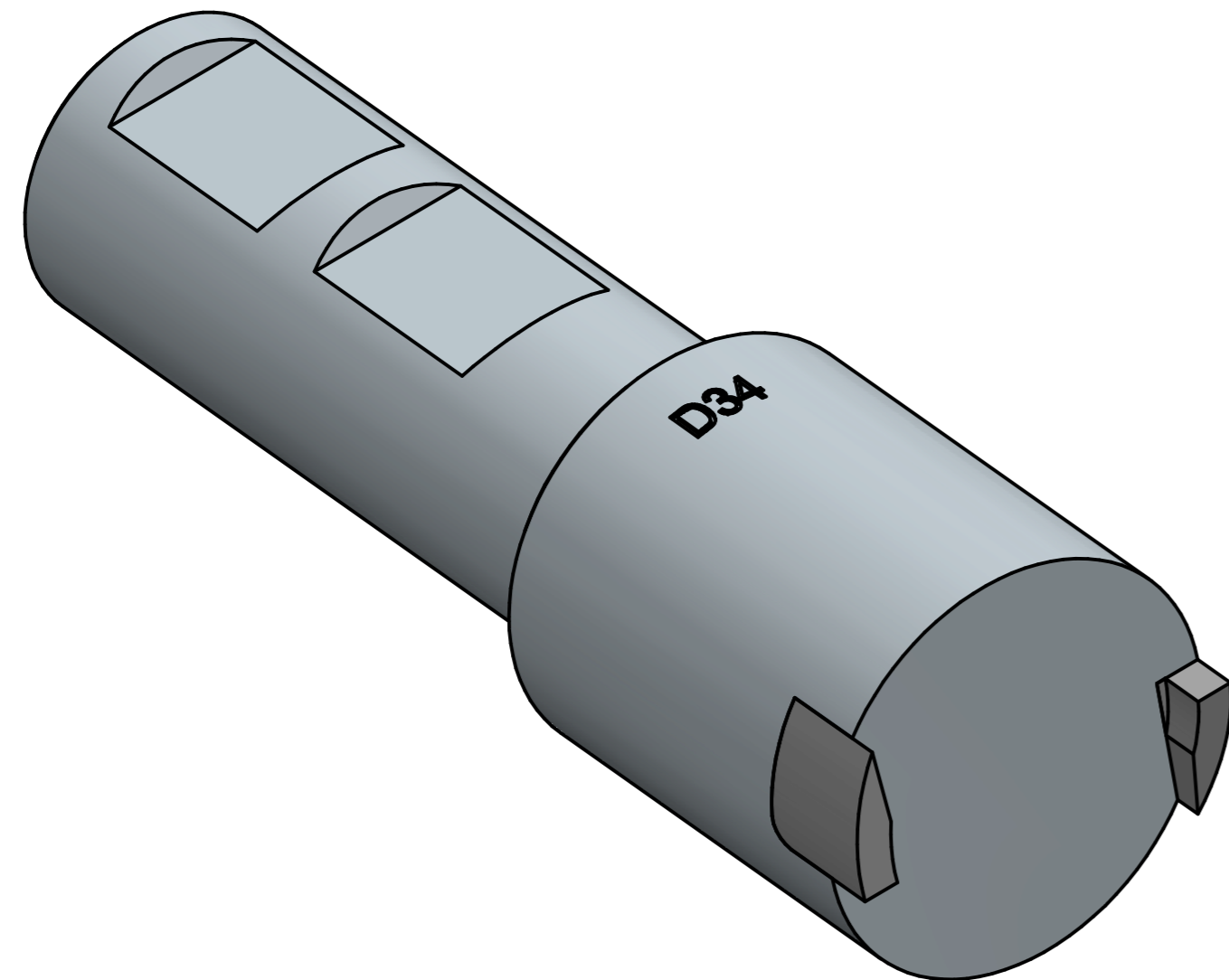
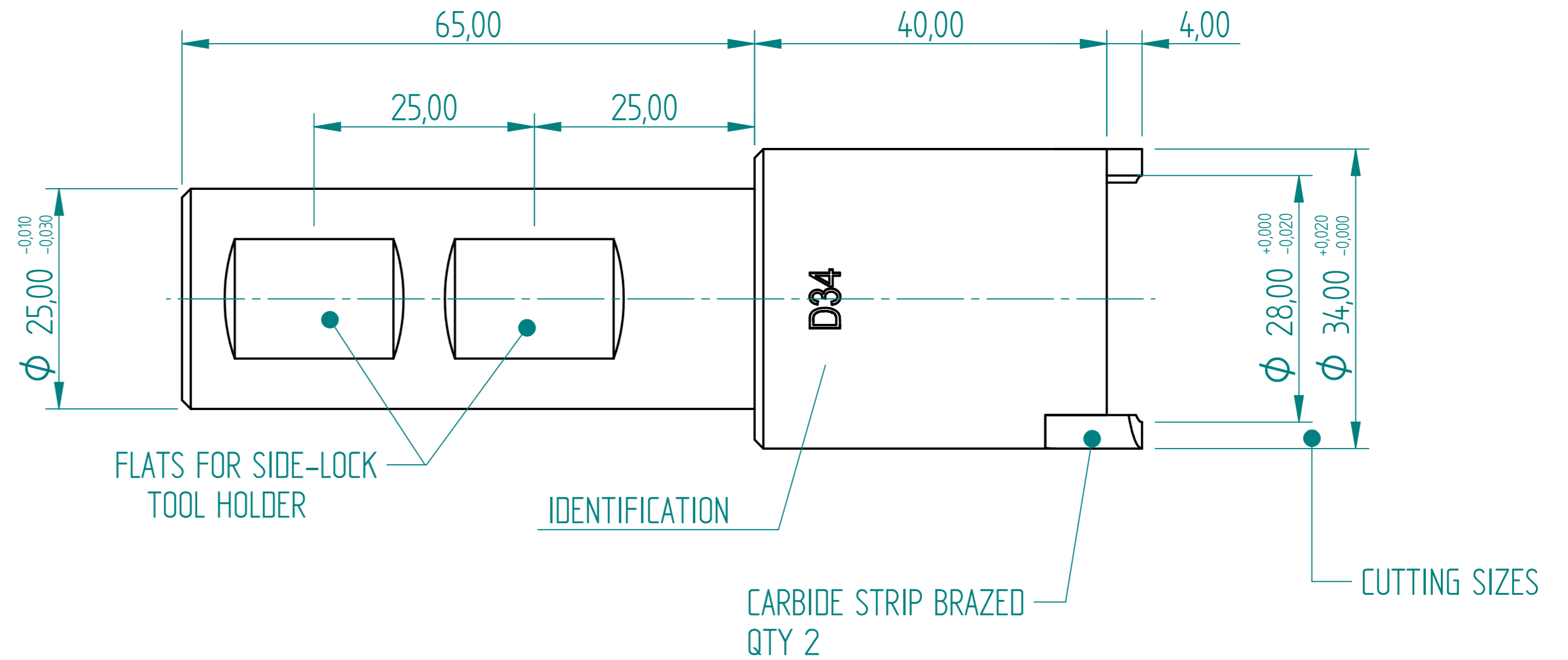
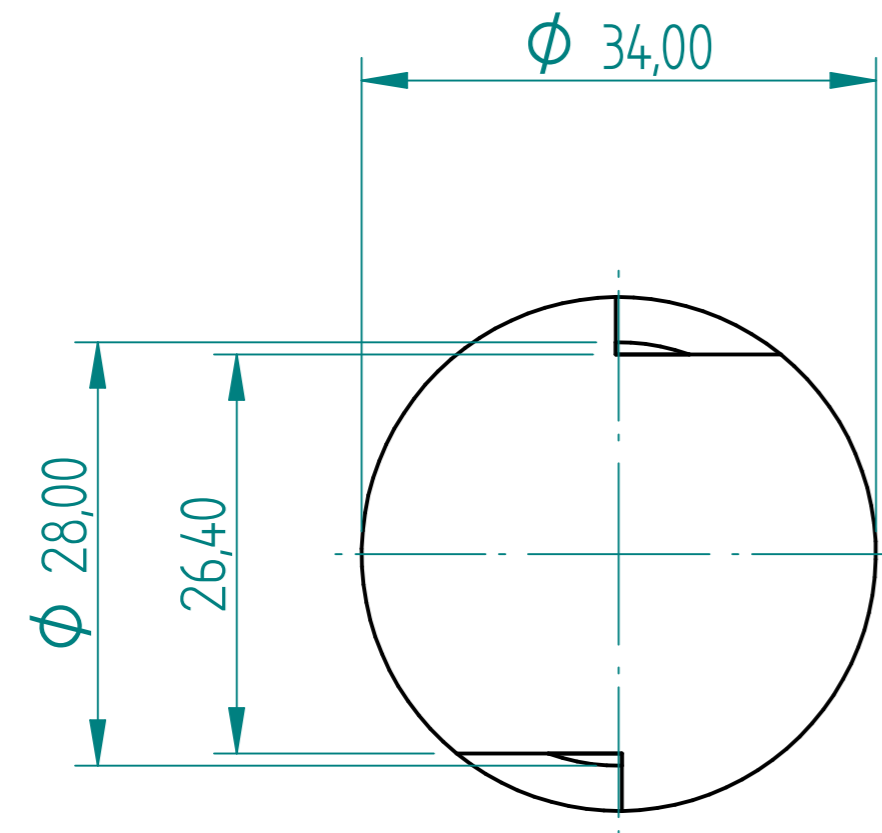

D34 O Ring Groove Bar
FOR MACHINING O-RING GROOVE
ON FLAT FACE IN CAST IRON 2.1 mm DEEP

DRAWN	NAME	DATE	PREMAC	
APPROVED	Dan	03/13/24		
MATERIAL			TITLE	
TREATMENT			FILE NAME: D34 O Ring Groove Bar.dft	
UNLESS OTHERWISE SPECIFIED DIMENSIONS ARE IN MILLIMETERS			SIZE A4	DWG NO
ANGLES $\pm 0,1^\circ$			REV	
2 PL $\pm 0,02$ 3 PL $\pm 0,005$			SCALE:	WEIGHT:
			SHEET 1 OF 1	