

Item Number	Document Number	Title	Quantity
1		Float Hyd Rem A Bonnet Asm	1
2		Float Hyd Rem B Bonnet Asm	1
3		Load Holding Check Asm	1
4		Port Relief	2
5	P2-021	O-Ring	2
6	P2-024	O-Ring	1
7	PV150-0010	Std Housing V150	1

REVISION HISTORY			
REV	DESCRIPTION	DATE	APPROVED

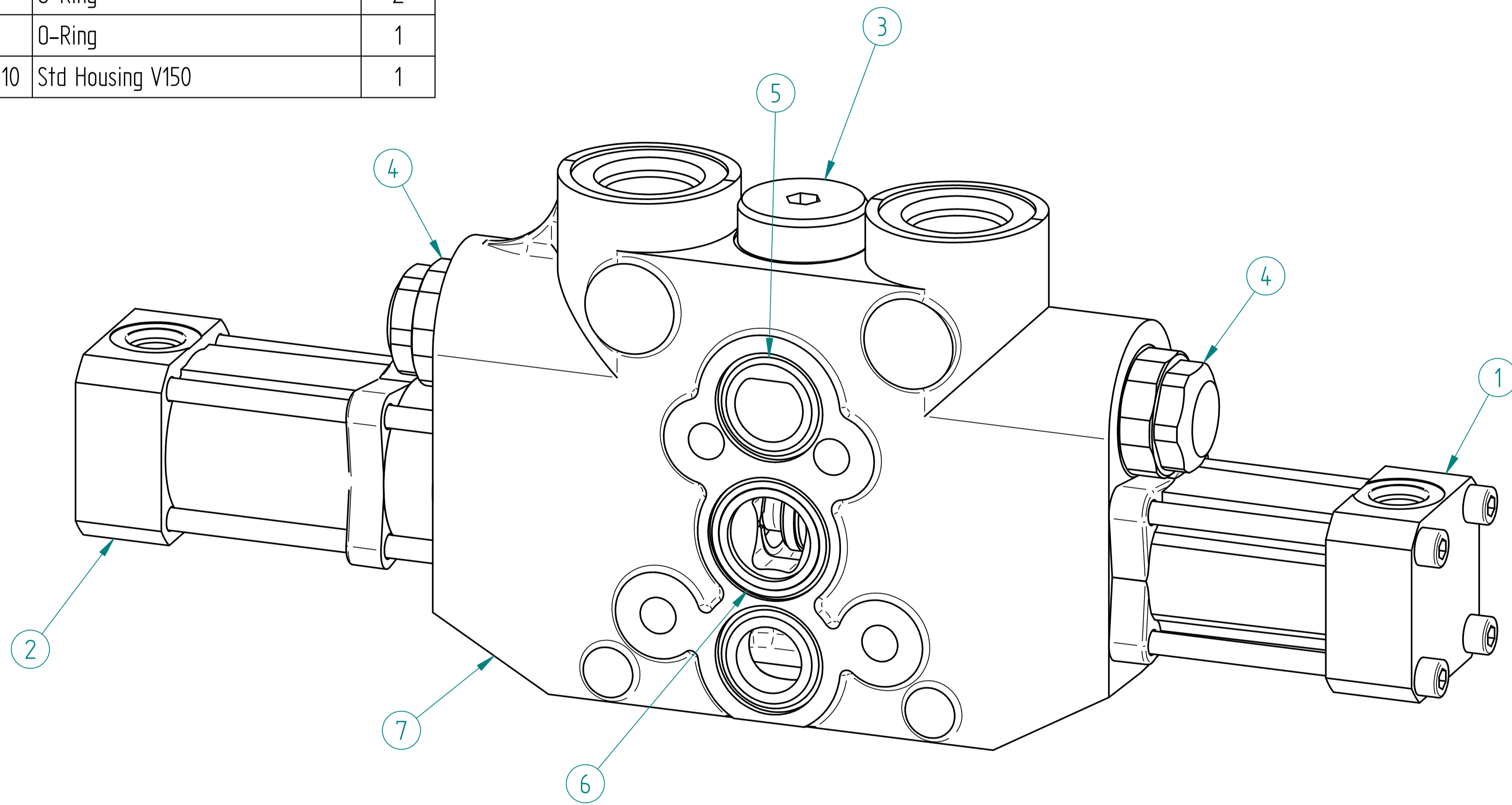

## V150 FLOAT HYDRAULIC REMOTE

NAME	DATE	PREMAC	
DRAWN: Dan	09/04/23	PRECISION MACHINE MANUFACTURERS (PTY)LTD.	
APPROVED		TITLE: Float Hyd Remote	
MATERIAL		SIZE: A2	DWG NO:
TREATMENT		FILE NAME: Float Hyd Remote.dft	REV:
UNLESS OTHERWISE SPECIFIED DIMENSIONS ARE IN MILLIMETERS ANGLES ±0.1°		SCALE:	WEIGHT:
2 PL ±0.02	3 PL ±0.005		SHEET 1 OF 6

Item Number	Document Number	Title	Quantity	Item Number	Document Number	Title	Quantity	Item Number	Document Number	Title	Quantity
1	2-029	O-Ring	2	10	P3-914	O-Ring	1	19	PV150-0089	H R Float Spring Cup	2
2	2-124	O-Ring	2	11	PV150-0010	Std Housing V150	1	20	PV150-0090	H R Spool Sealing Washer	2
3	2-127	O-Ring	3	12	PV150-0021	Float Spool	1	21	PV150-0092	H R Float A Positioner Bolt	1
4	2-212	O-Ring	2	13	PV150-0081	Hyd Rem Bonnet Cut Off	2	22	PV150-0093	H R Float B Positioner Bolt	1
5	3-910	O-Ring	2	14*	PV150-0081	Hyd Rem Bonnet Cut Off	1	23	PV150-0095	H R Float Washer	2
6	M6-100	Cap Screw	4	15	PV150-0082	Bonnet End Cap	1	24	PV150-0096	H R Spool Sealing Spacer	1
7*	M6-110	Cap Screw	4	16	PV150-0082	Bonnet End Cap	1				
8	P2-022	O-Ring	2	17	PV150-0086	H R Float Outer Spring	1				
9	P2-023	O-Ring	2	18	PV150-0087	H R Float Inner Spring	2				

REVISION HISTORY			
REV	DESCRIPTION	DATE	APPROVED

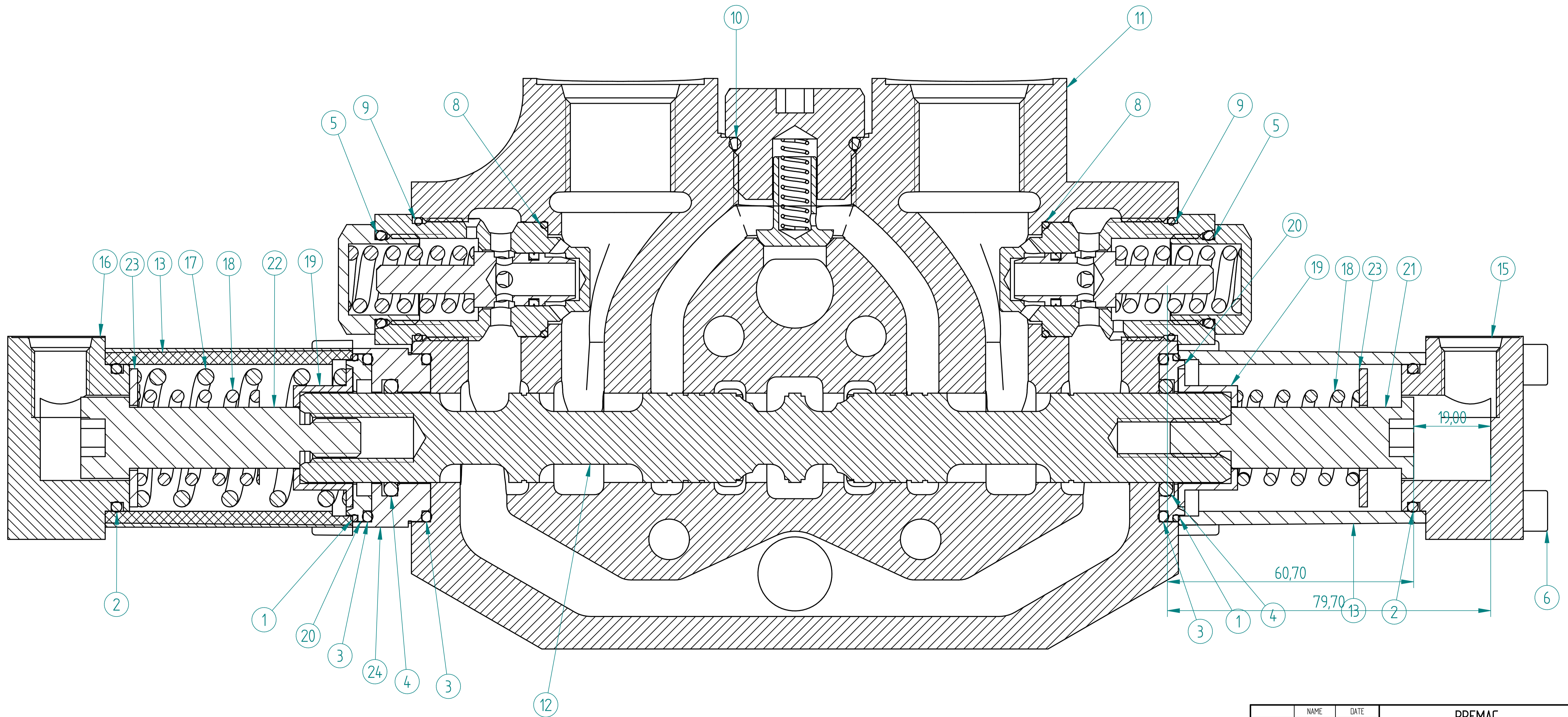

## V150 FLOAT HYDRAULIC REMOTE

NAME	DATE	PREMAC	
DRAWN	Dan	PRECISION MACHINE MANUFACTURERS (PTY)LTD.	
APPROVED	09/04/23	TITLE	
MATERIAL		Float Hyd Remote	
TREATMENT		SIZE	DWG NO
UNLESS OTHERWISE SPECIFIED DIMENSIONS ARE IN MILLIMETERS ANGLES *XX*		A1	REV
1:1 SCALE 2 PL ±0.02 3 PL ±0.005		FILE NAME: Float Hyd Remote.dft	SCALE
		WEIGHT	SHEET 2 OF 6

REVISION HISTORY			
REV	DESCRIPTION	DATE	APPROVED

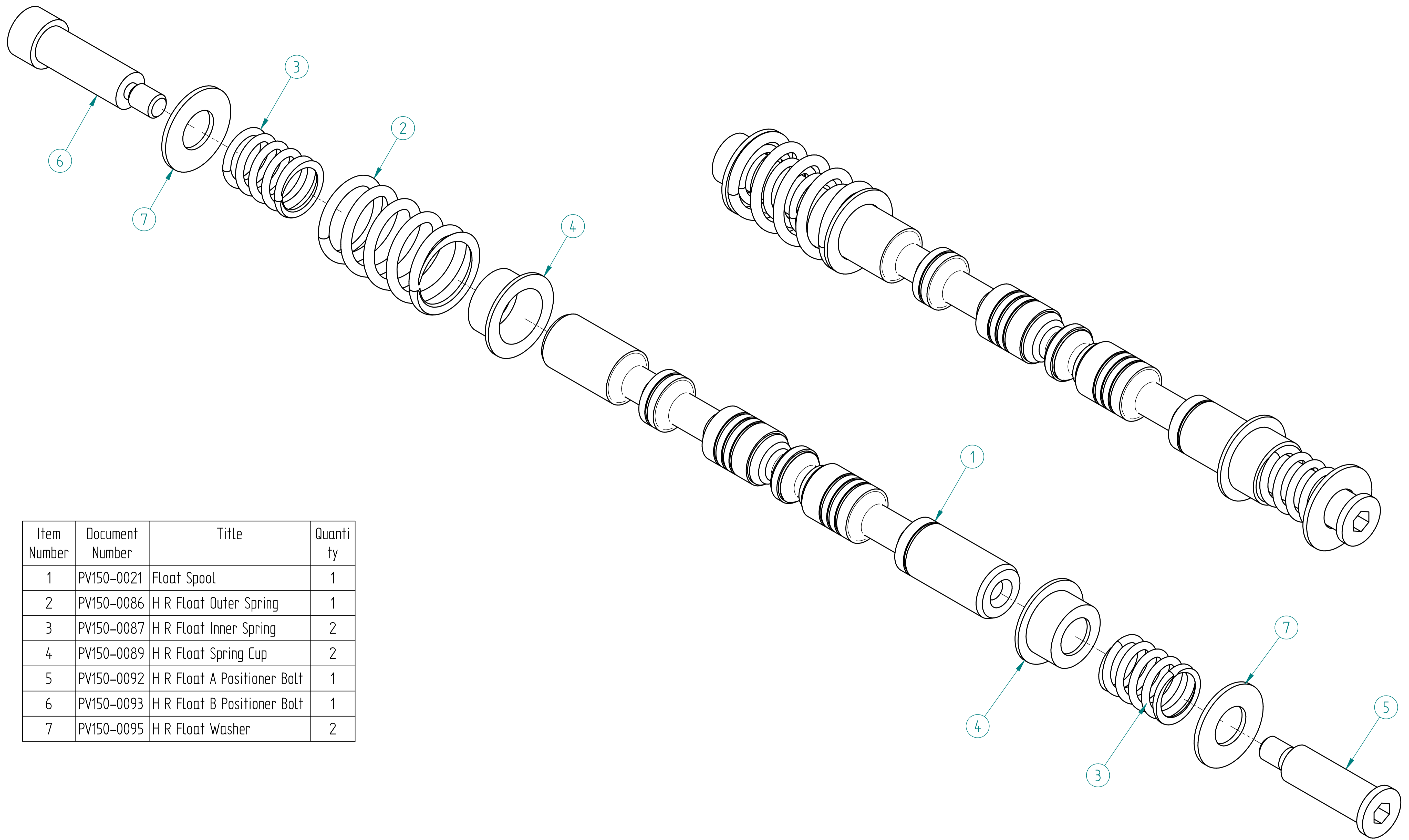

Item Number	Document Number	Title	Quantity
1	PV150-0021	Float Spool	1
2	PV150-0086	H R Float Outer Spring	1
3	PV150-0087	H R Float Inner Spring	2
4	PV150-0089	H R Float Spring Cup	2
5	PV150-0092	H R Float A Positioner Bolt	1
6	PV150-0093	H R Float B Positioner Bolt	1
7	PV150-0095	H R Float Washer	2

## FLOAT HYD REM SPOOL

NAME	DATE	PREMAC PRECISION MACHINE MANUFACTURERS (PTY)LTD.
DRAWN Dan	09/04/23	
APPROVED		TITLE
MATERIAL		Float Hyd Remote
TREATMENT		SIZE DWG NO
UNLESS OTHERWISE SPECIFIED DIMENSIONS ARE IN MILLIMETERS ANGLES *XX*		A1
1:10 SCALE	2 PL ±0.02 3 PL ±0.005	FILE NAME: Float Hyd Remote.dft
SCALE:	WEIGHT:	SHEET 3 OF 6

REVISION HISTORY			
REV	DESCRIPTION	DATE	APPROVED

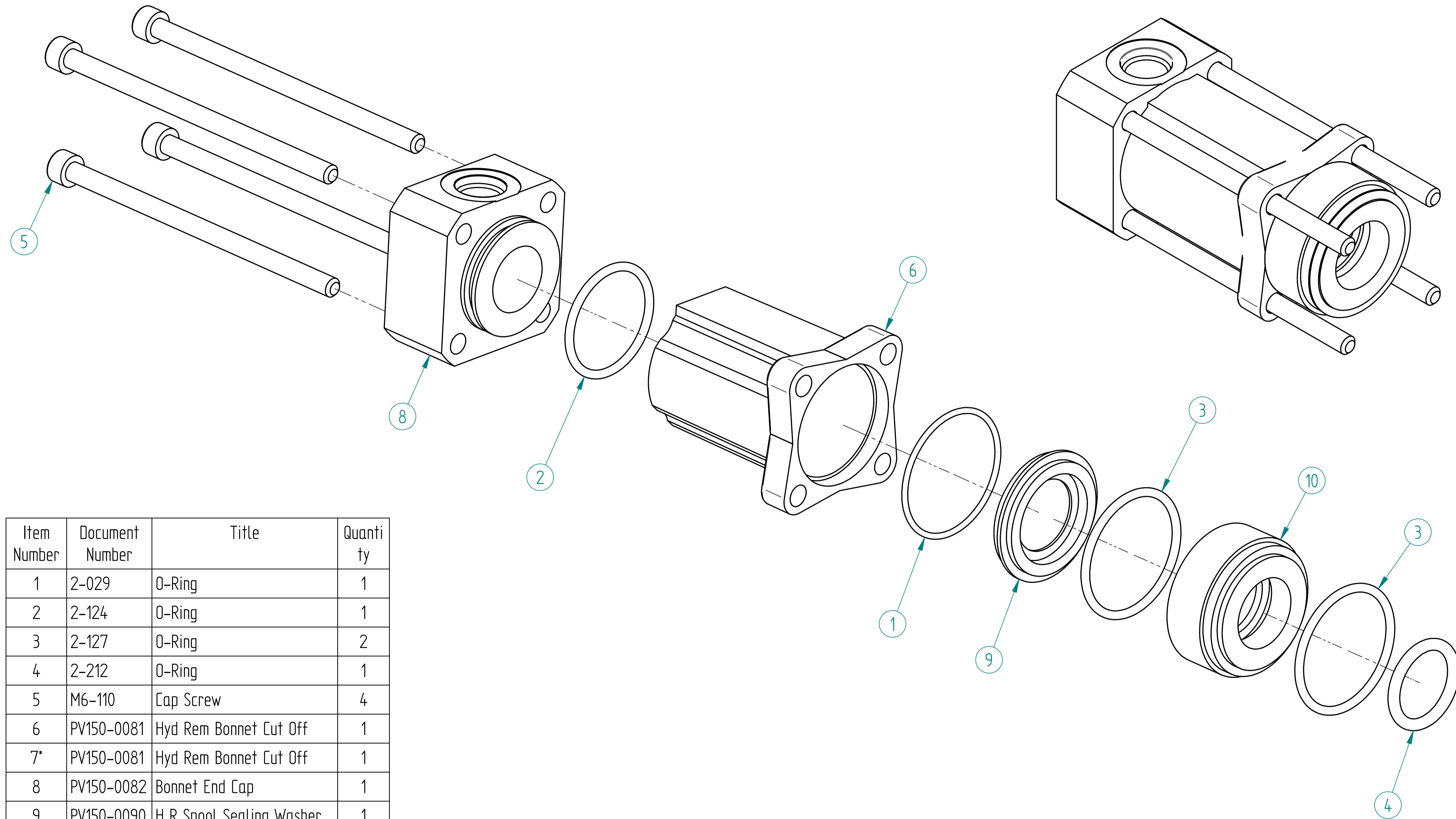

Item Number	Document Number	Title	Quantity
1	2-029	O-Ring	1
2	2-124	O-Ring	1
3	2-127	O-Ring	2
4	2-212	O-Ring	1
5	M6-110	Cap Screw	4
6	PV150-0081	Hyd Rem Bonnet Cut Off	1
7*	PV150-0081	Hyd Rem Bonnet Cut Off	1
8	PV150-0082	Bonnet End Cap	1
9	PV150-0090	H R Spool Sealing Washer	1
10	PV150-0096	H R Spool Sealing Spacer	1

## FLOAT HYD REM B BONNET

NAME	DATE	PREMAC	
DRAWN Dan	09/04/23	PRECISION MACHINE MANUFACTURERS (PTY)LTD.	
APPROVED		TITLE	
MATERIAL		Float Hyd Remote	
TREATMENT		SIZE A1	DWG NO
UNLESS OTHERWISE SPECIFIED DIMENSIONS ARE IN MILLIMETERS ANGLES *XX°		SCALE:	WEIGHT:
1:10 SCALE	2 PL ±0.02 3 PL ±0.005	FILE NAME: Float Hyd Remote.dft	SHEET 4 OF 6

REVISION HISTORY			
REV	DESCRIPTION	DATE	APPROVED

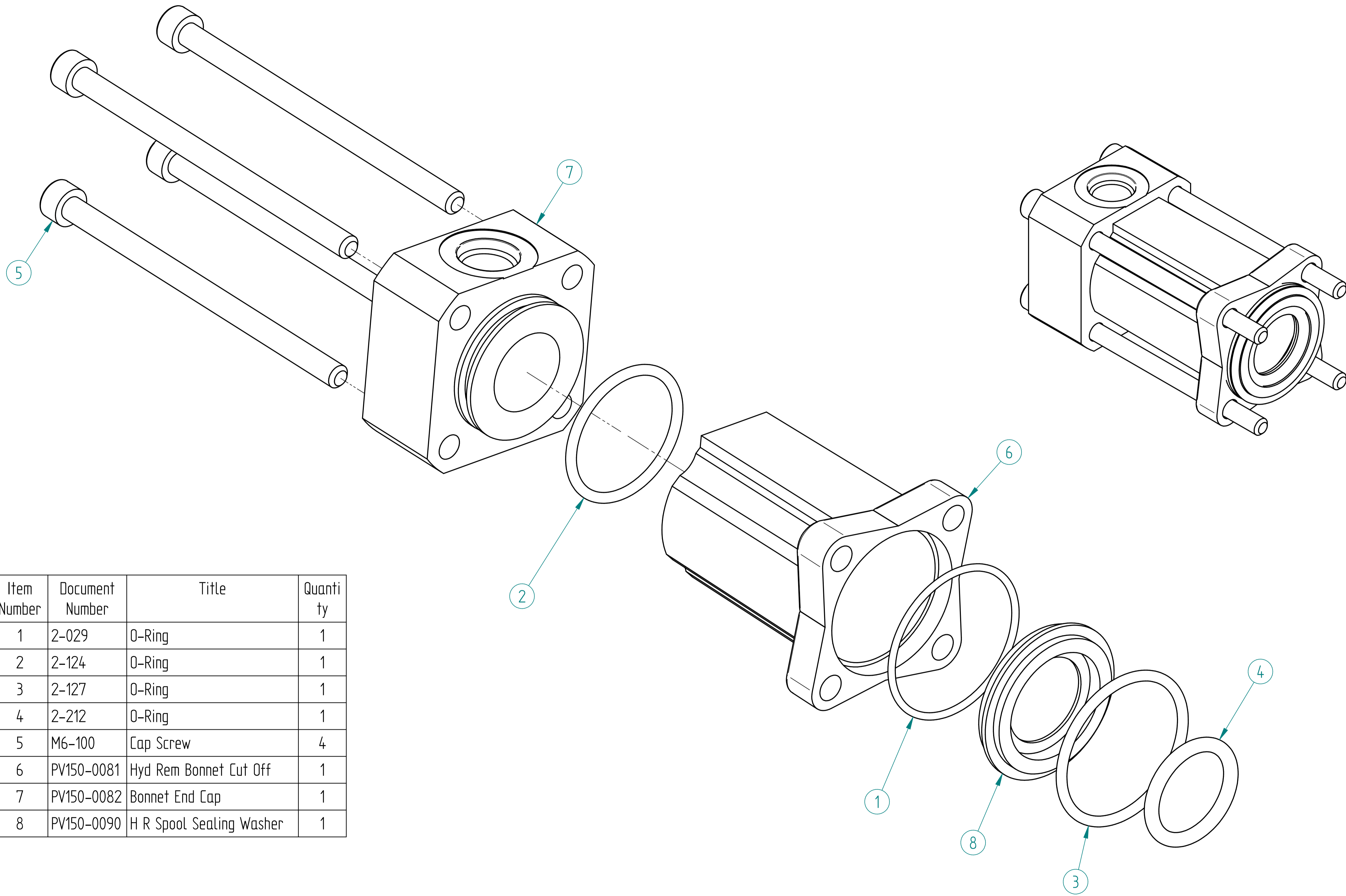

Item Number	Document Number	Title	Quantity
1	2-029	O-Ring	1
2	2-124	O-Ring	1
3	2-127	O-Ring	1
4	2-212	O-Ring	1
5	M6-100	Cap Screw	4
6	PV150-0081	Hyd Rem Bonnet Cut Off	1
7	PV150-0082	Bonnet End Cap	1
8	PV150-0090	H R Spool Sealing Washer	1

## FLOAT HYD REM A BONNET

NAME	DATE	PREMAC	
DRAWN: Dan	09/04/23	PRECISION MACHINE MANUFACTURERS (PTY)LTD.	
APPROVED		TITLE: Float Hyd Remote	
MATERIAL		SIZE: A1	DWG NO:
TREATMENT		FILE NAME: Float Hyd Remote.dft	REV:
UNLESS OTHERWISE SPECIFIED DIMENSIONS ARE IN MILLIMETERS ANGLES *XX*		SCALE:	WEIGHT:
1:10 SCALE	2 PL ±0.02 3 PL ±0.005		SHEET 5 OF 6

REVISION HISTORY			
REV	DESCRIPTION	DATE	APPROVED

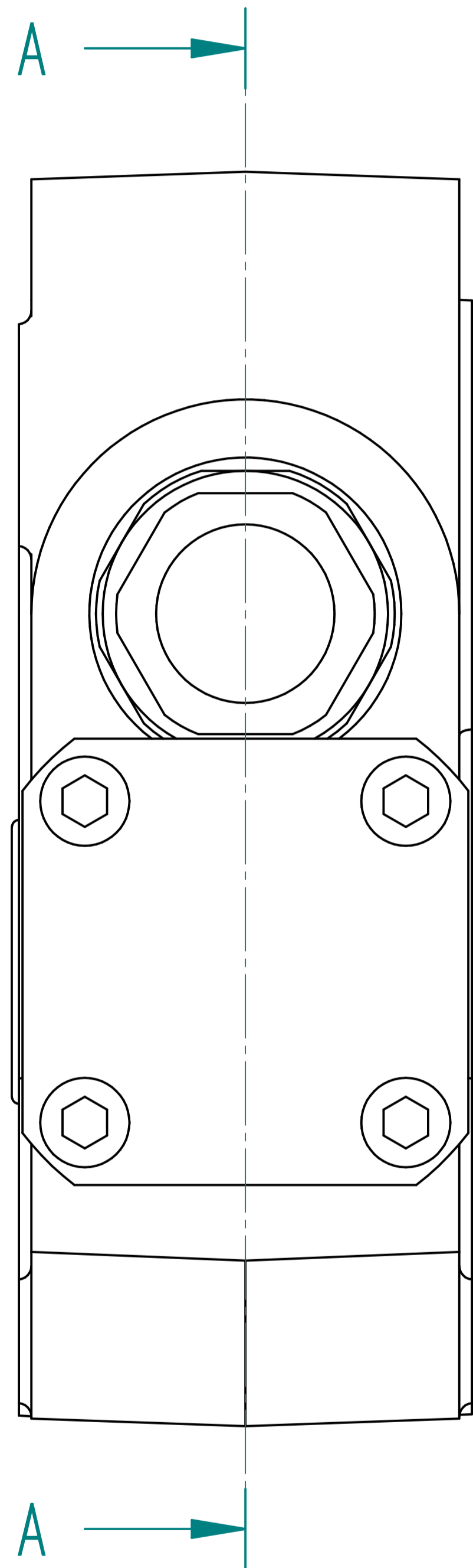

	NAME	DATE	PREMAC	
DRAWN	Dan	09/04/23	PRECISION MACHINE MANUFACTURERS (PTY)LTD.	
APPROVED			TITLE	
MATERIAL			Float Hyd Remote	
TREATMENT				
	UNLESS OTHERWISE SPECIFIED DIMENSIONS ARE IN MILLIMETERS ANGLES ±0.1°		SIZE A2	DWG NO 
	2 PL ±0.02 3 PL ±0.005		FILE NAME: Float Hyd Remote.dft	REV 
			SCALE:	WEIGHT: SHEET 6 OF 6