

REVISION HISTORY			
REV	DESCRIPTION	DATE	APPROVED

BACK SPOT FACING DIAMETER

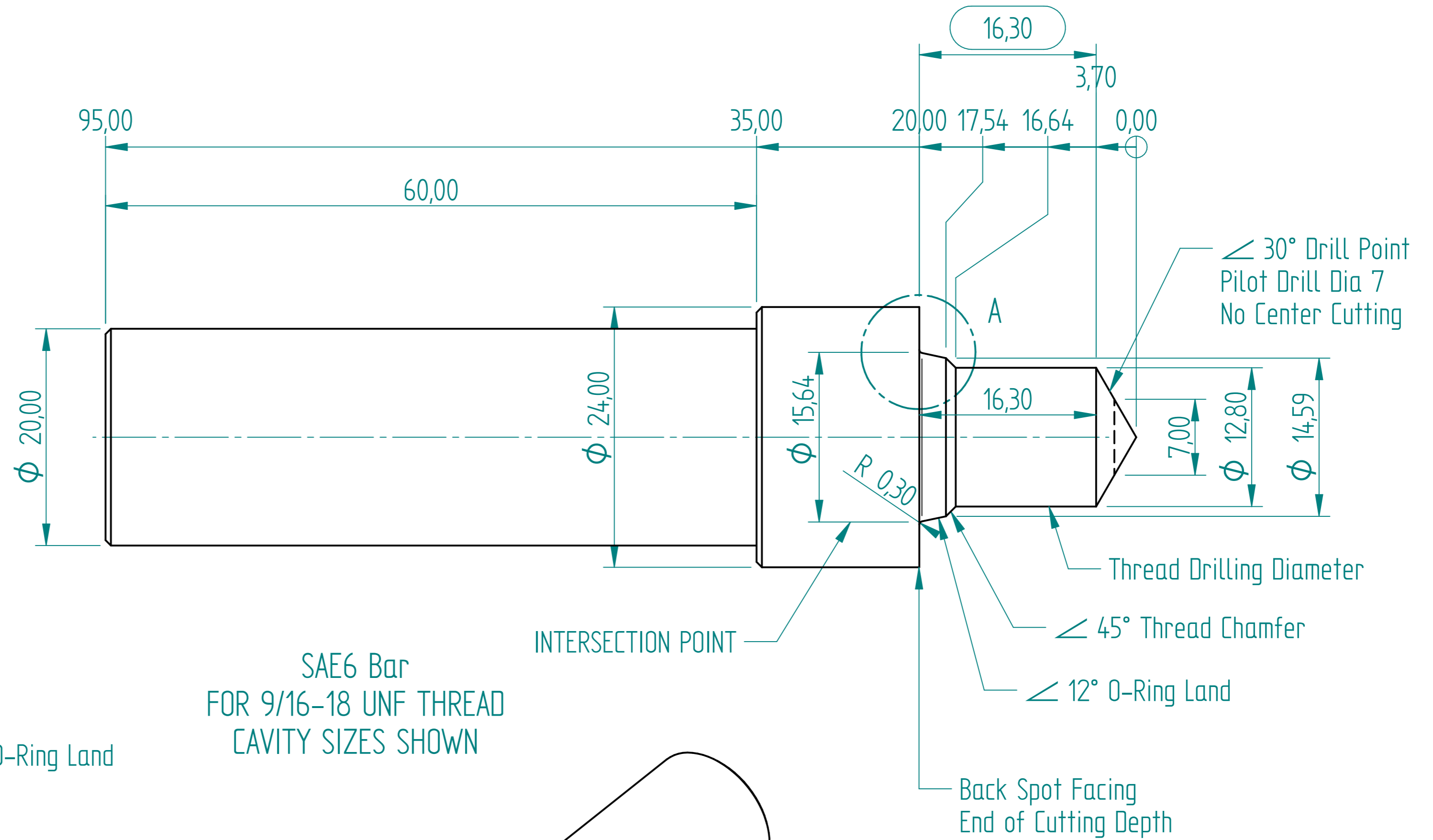

SAE6 Bar
FOR 9/16-18 UNF THREAD
CAVITY SIZES SHOWN

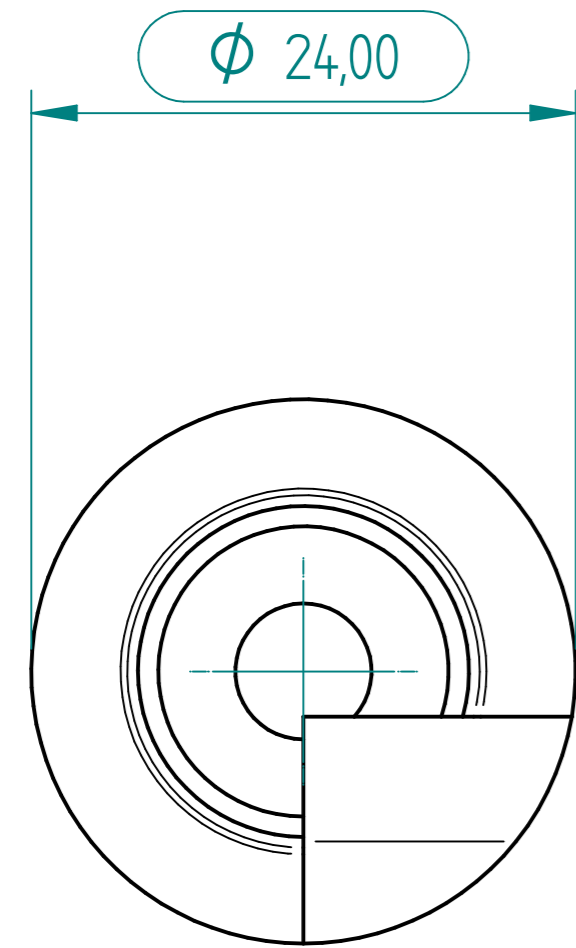
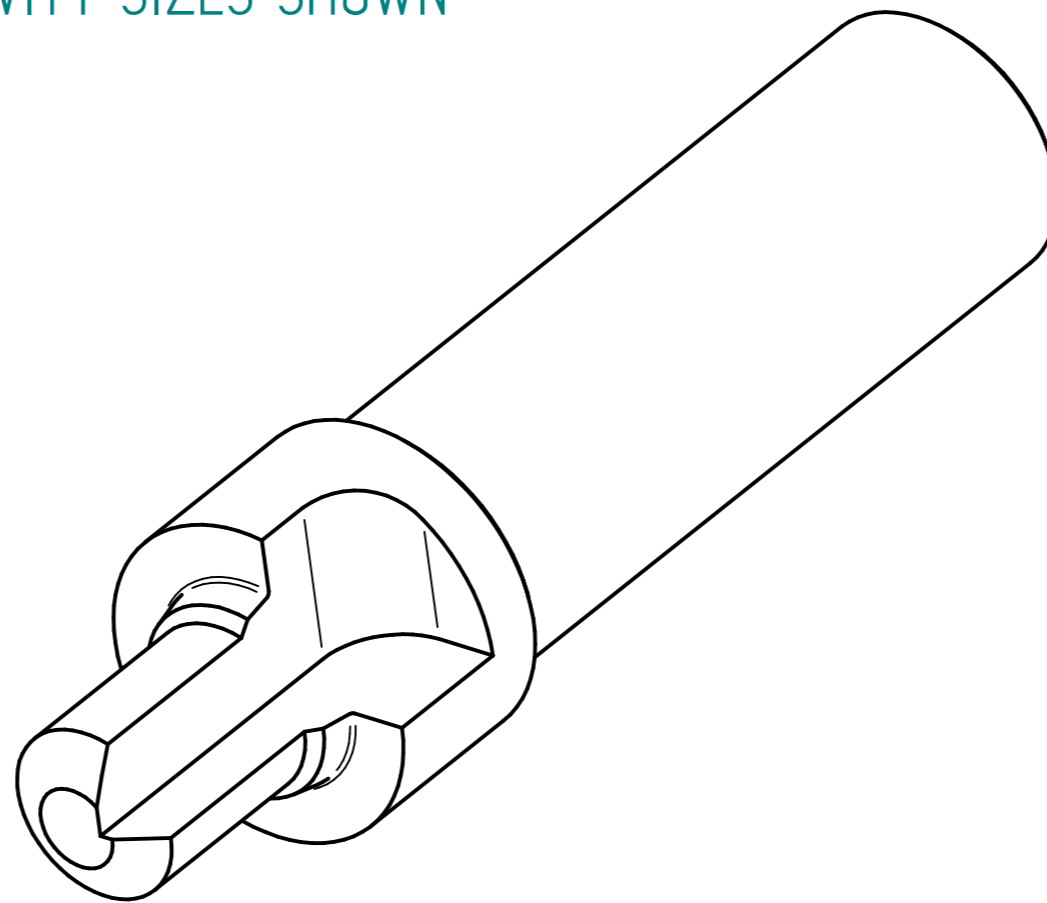

Back Spot Facing

O-Ring Land

INTERSECTION POINT

DETAIL A

	NAME	DATE	PREMAC	
DRAWN	Dan	10/18/19		
APPROVED				
MATERIAL				
TREATMENT			TITLE	
UNLESS OTHERWISE SPECIFIED DIMENSIONS ARE IN MILLIMETERS			SIZE A4	DWG NO
1 ST ANGLE 2 PL ±0.02 3 PL ±0.005			FILE NAME: SAE6 Bar.dft	REV
			SCALE:	WEIGHT:
			SHEET 3 OF 3	