

REVISION HISTORY			
REV	DESCRIPTION	DATE	APPROVED

BACK SPOT FACING DIAMETER

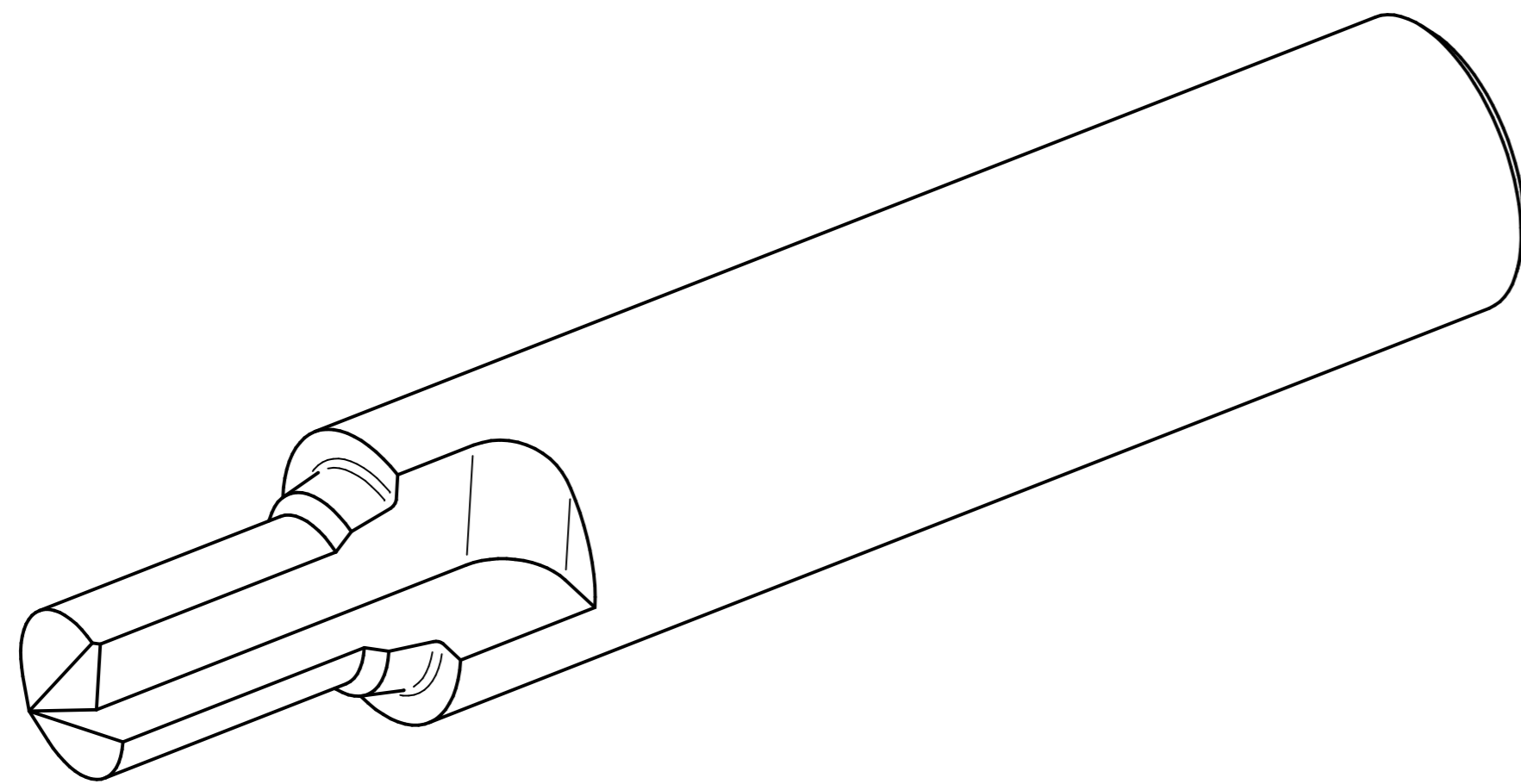
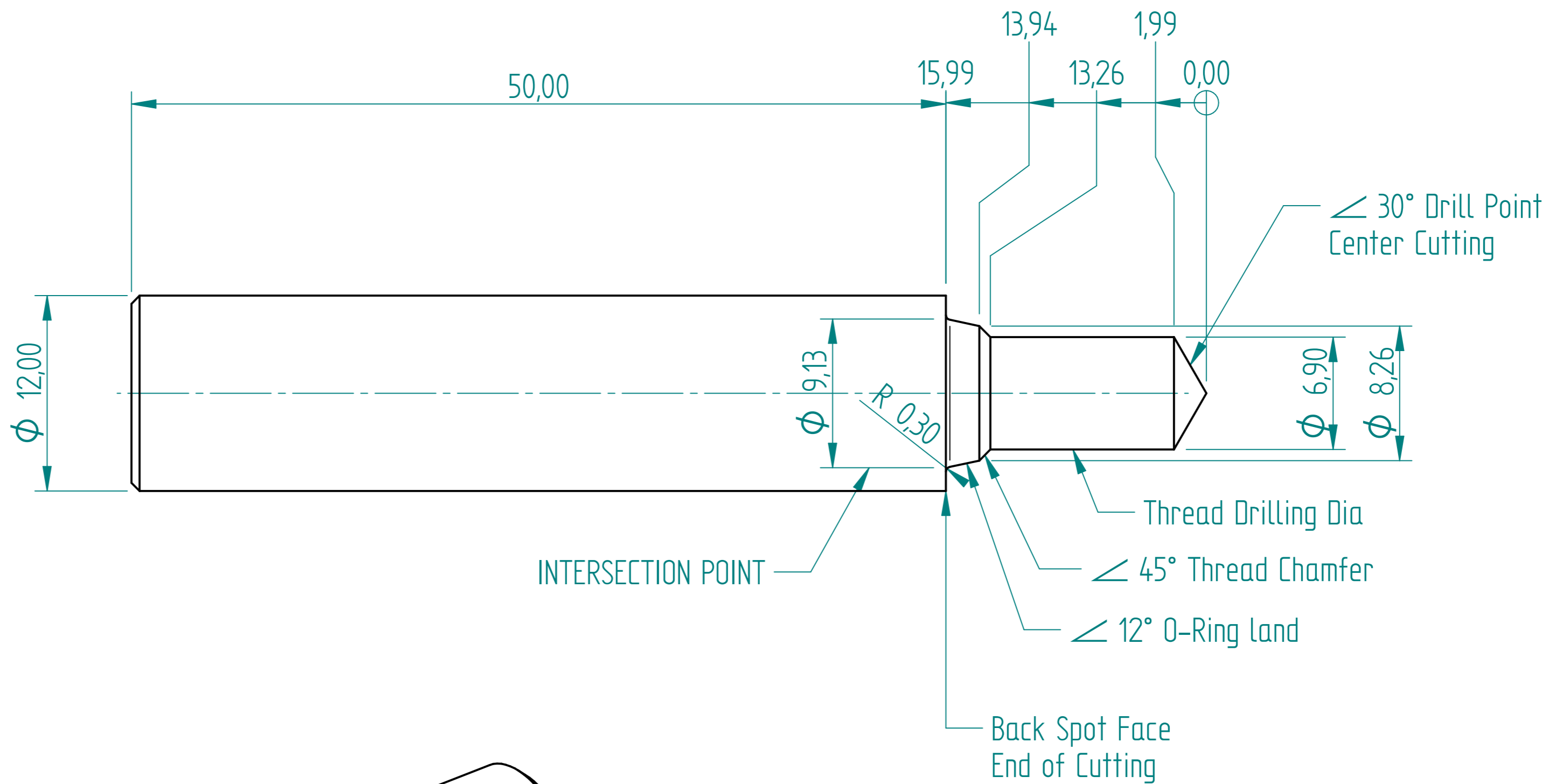
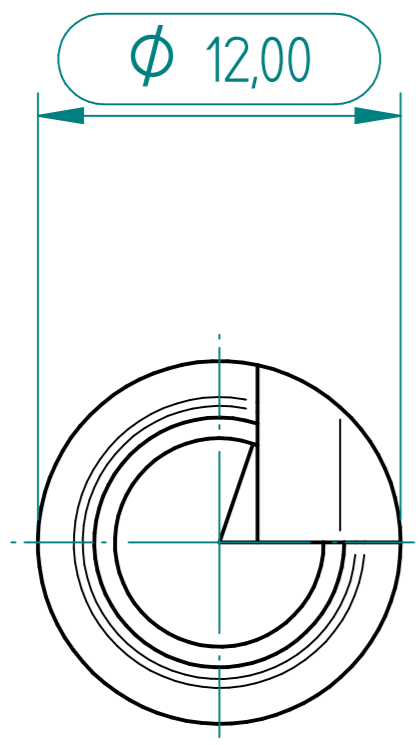

SAE 2 Bar  
FOR 5/16-24 UNF THREAD  
CAVITY SIZES SHOWN

	NAME	DATE	<b>PREMAC</b>	
DRAWN	Dan	09/25/20		
APPROVED				
MATERIAL				
TREATMENT			TITLE	
UNLESS OTHERWISE SPECIFIED DIMENSIONS ARE IN MILLIMETERS			SIZE A4	DWG NO
1 <sup>ST</sup> ANGLE ANGLES $\pm$ 0.1°			FILE NAME: SAE 2 Bar.dft	REV
2 PL $\pm$ 0.02 3 PL $\pm$ 0.005			SCALE:	WEIGHT:
			SHEET 1 OF 1	