

REVISION HISTORY			
REV	DESCRIPTION	DATE	APPROVED

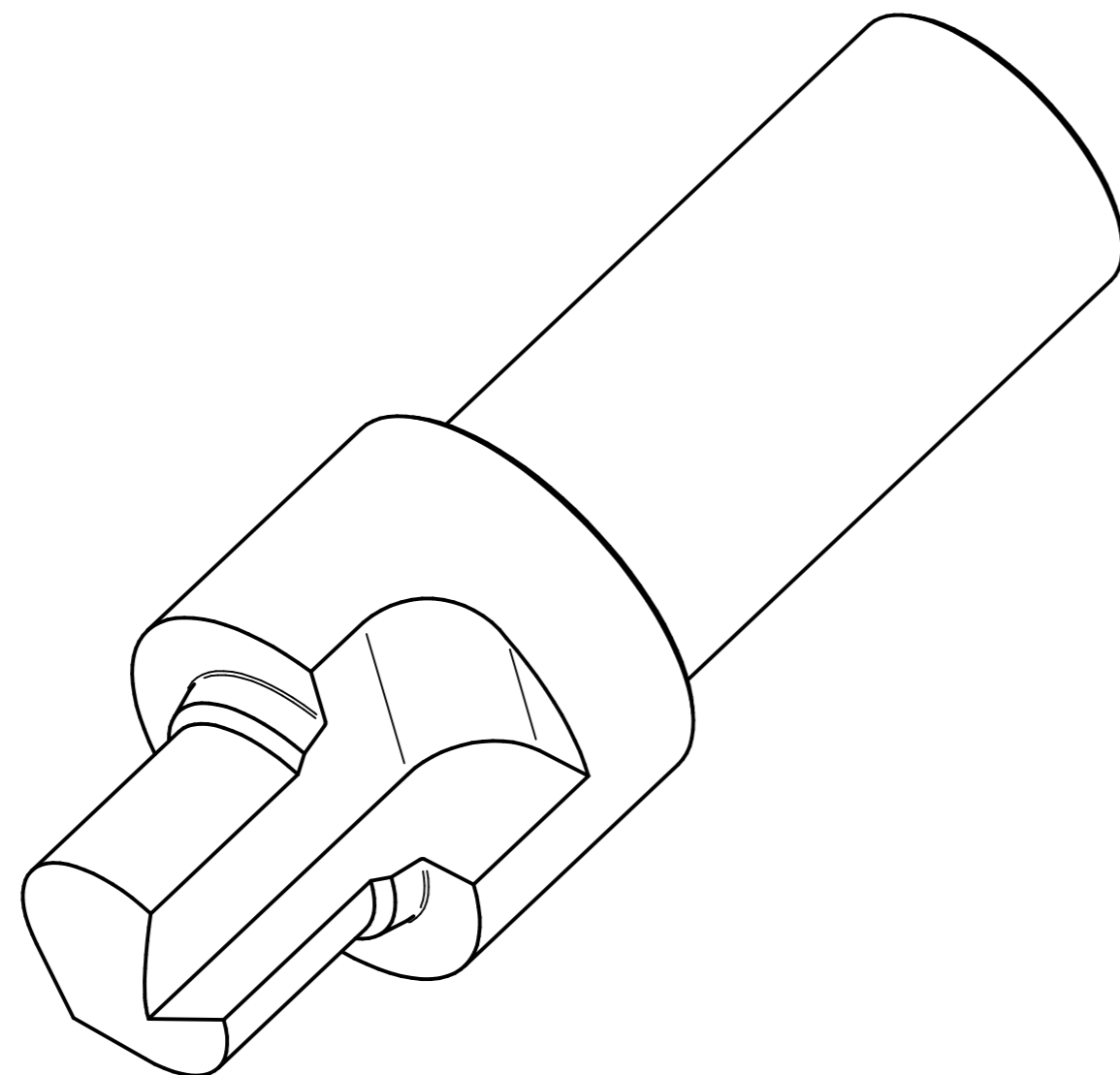
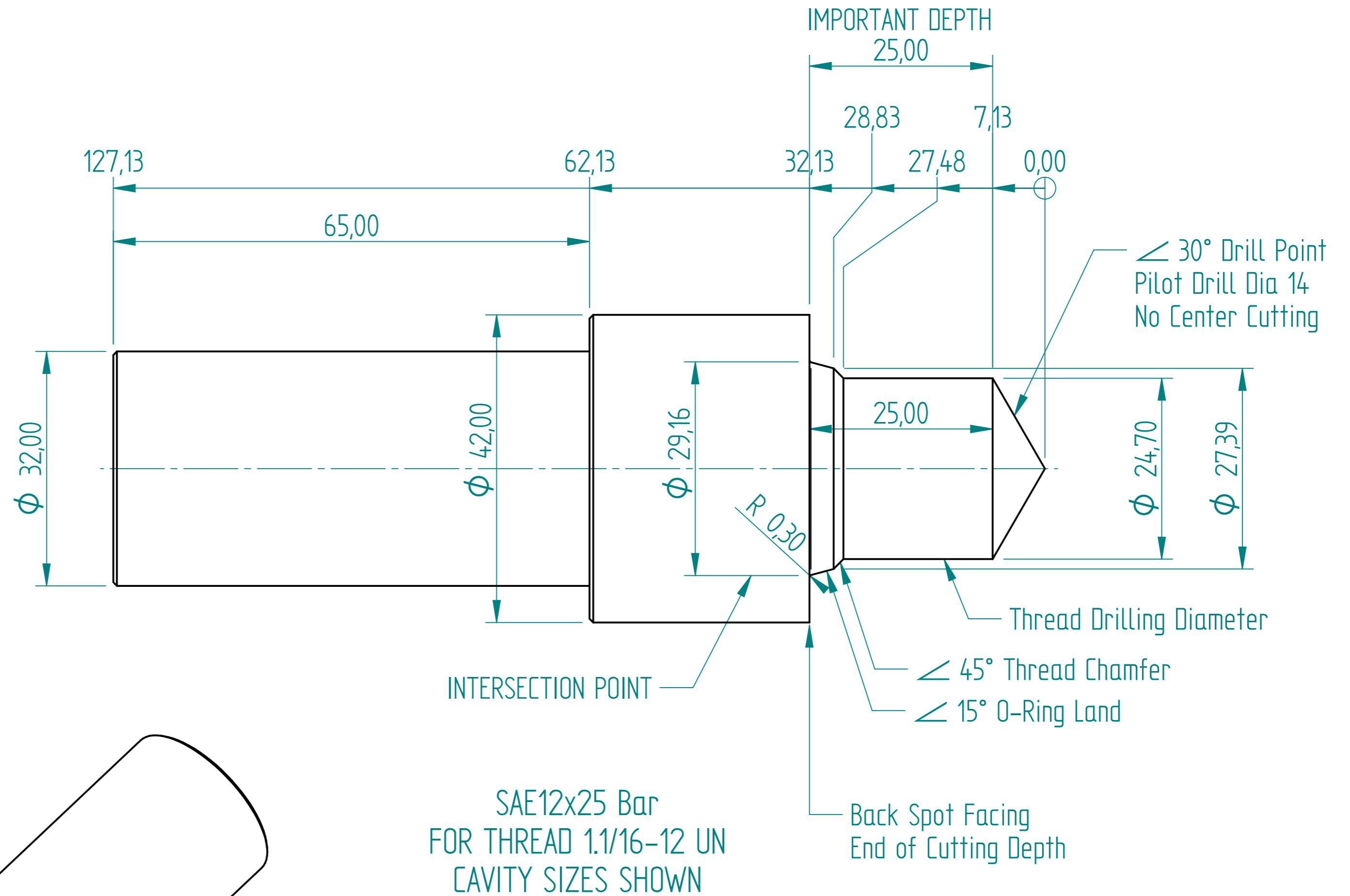
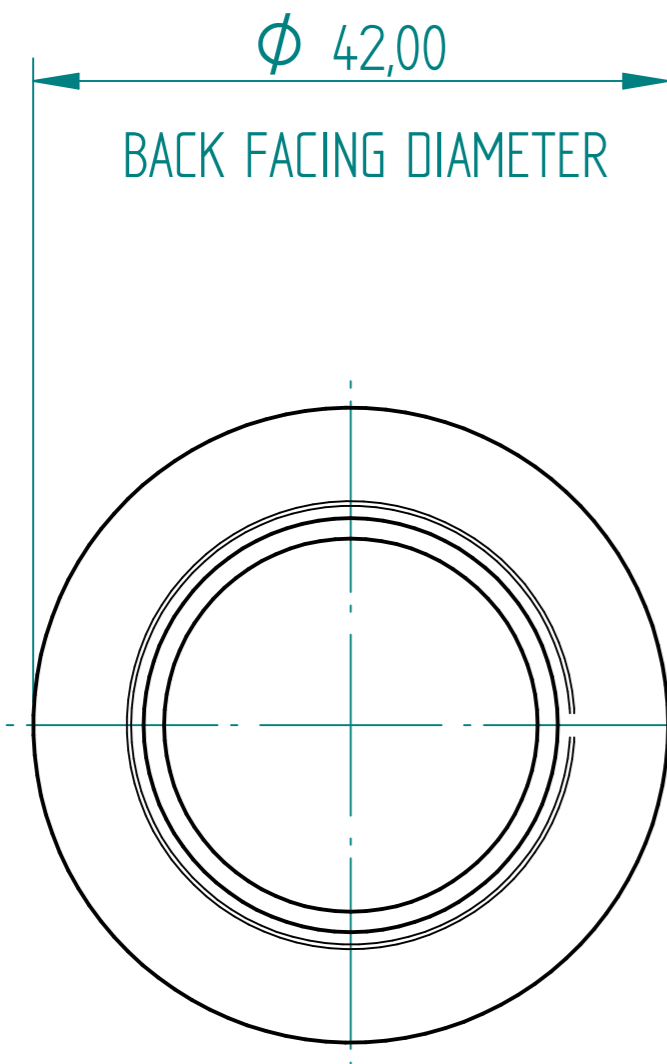

	NAME	DATE	PREMAC	
DRAWN	Dan	10/16/19		
APPROVED				
MATERIAL				
TREATMENT			TITLE	
UNLESS OTHERWISE SPECIFIED DIMENSIONS ARE IN MILLIMETERS 1 ST ANGLE ANGLS ±0.1°			SIZE A4	DWG NO
2 PL ±0.02 3 PL ±0.005			FILE NAME: SAE12x22.5 Bar.dft	REV
			SCALE:	WEIGHT:
			SHEET 3 OF 3	