

REVISION HISTORY			
REV	DESCRIPTION	DATE	APPROVED

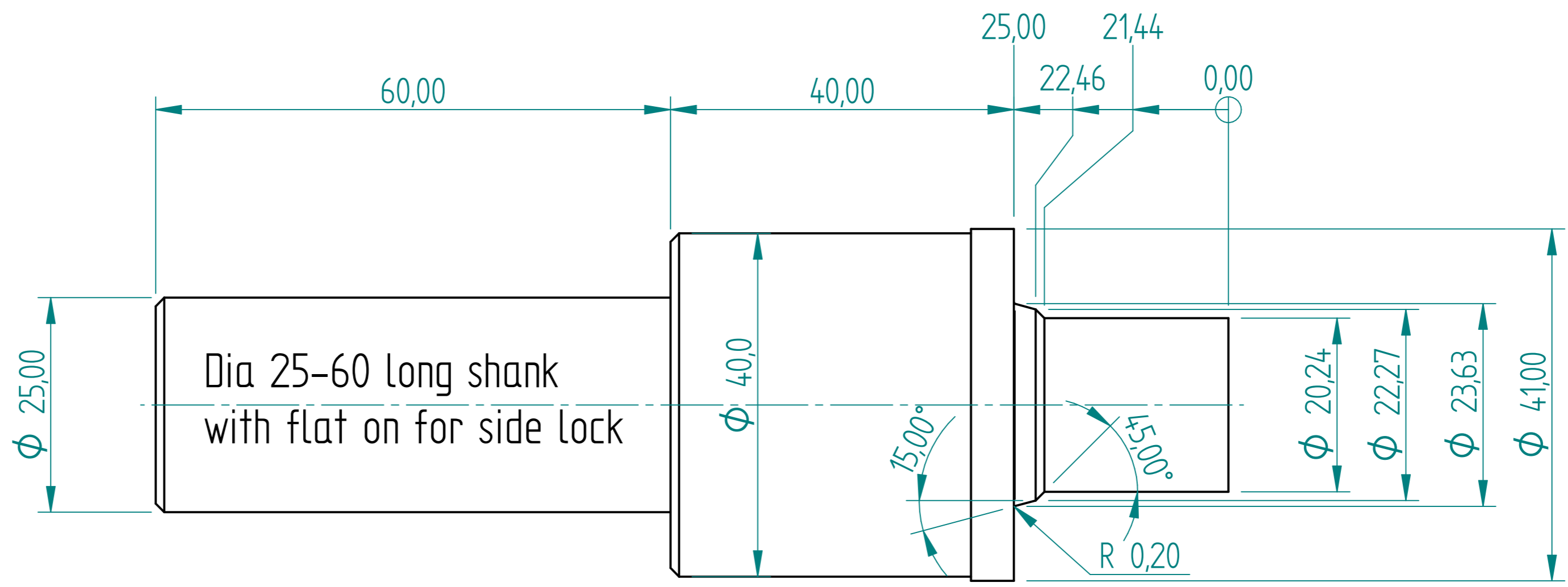

SAE-10 by 25 mm DEEP

SAE10 CAVITY SIZES

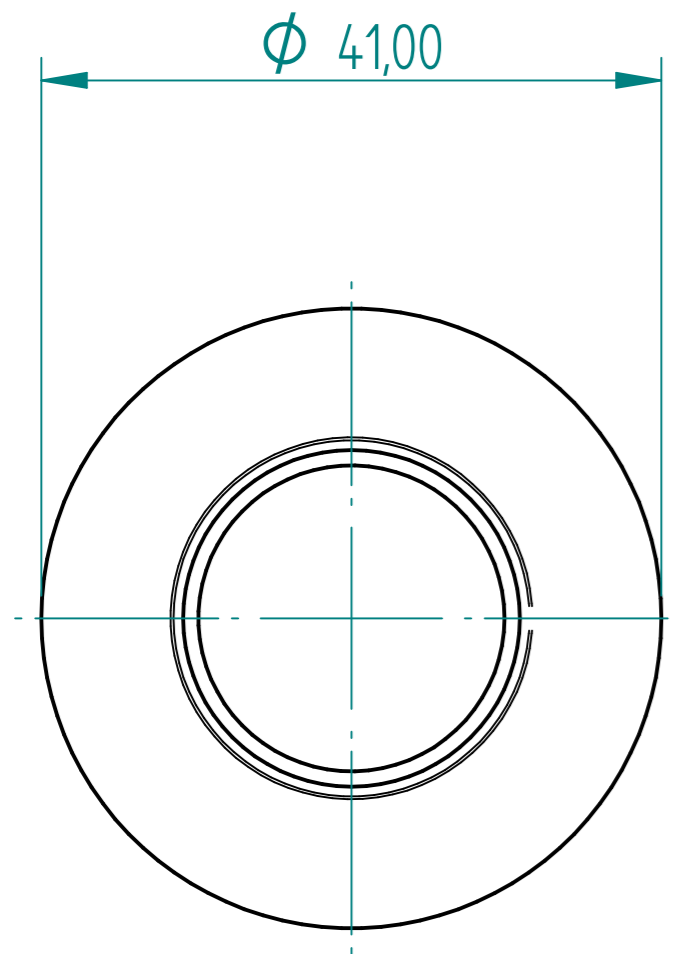
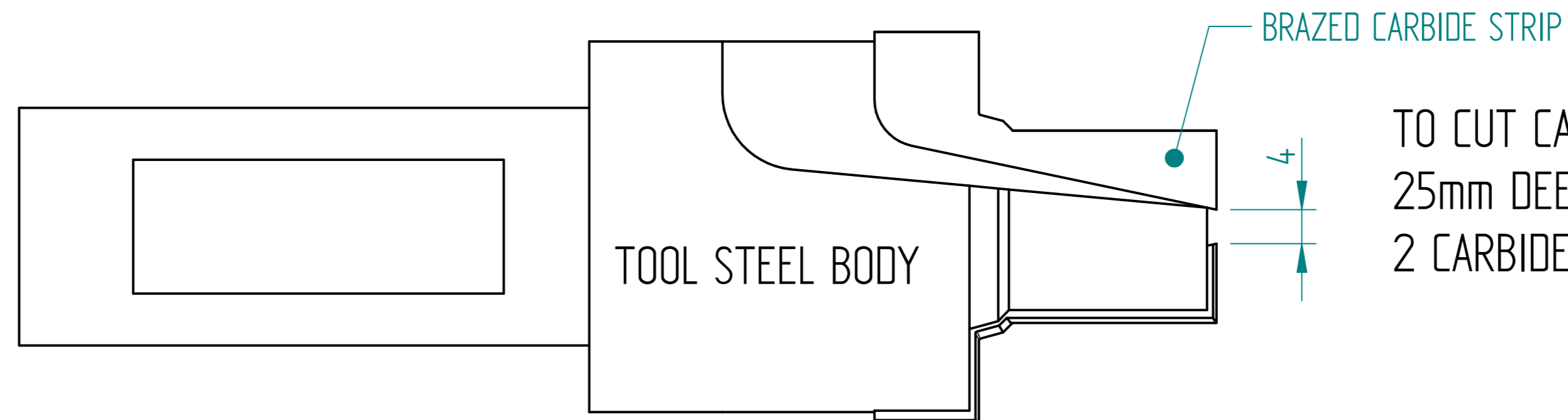

TO CUT CAVITY FOR SAE10 BY 25mm DEEP IN CAST IRON
2 CARBIDE STRIPS

	NAME	DATE	PREMAC	
DRAWN	Dan	10/15/19		
APPROVED			TITLE	
MATERIAL			SIZE	DWG NO
TREATMENT			A4	
UNLESS OTHERWISE SPECIFIED DIMENSIONS ARE IN MILLIMETERS			FILE NAME: SAE10x25.dft	REV
1st ANGLE 2 PL ±0.02 3 PL ±0.005			SCALE:	WEIGHT:
			SHEET 1 OF 2	

REVISION HISTORY			
REV	DESCRIPTION	DATE	APPROVED

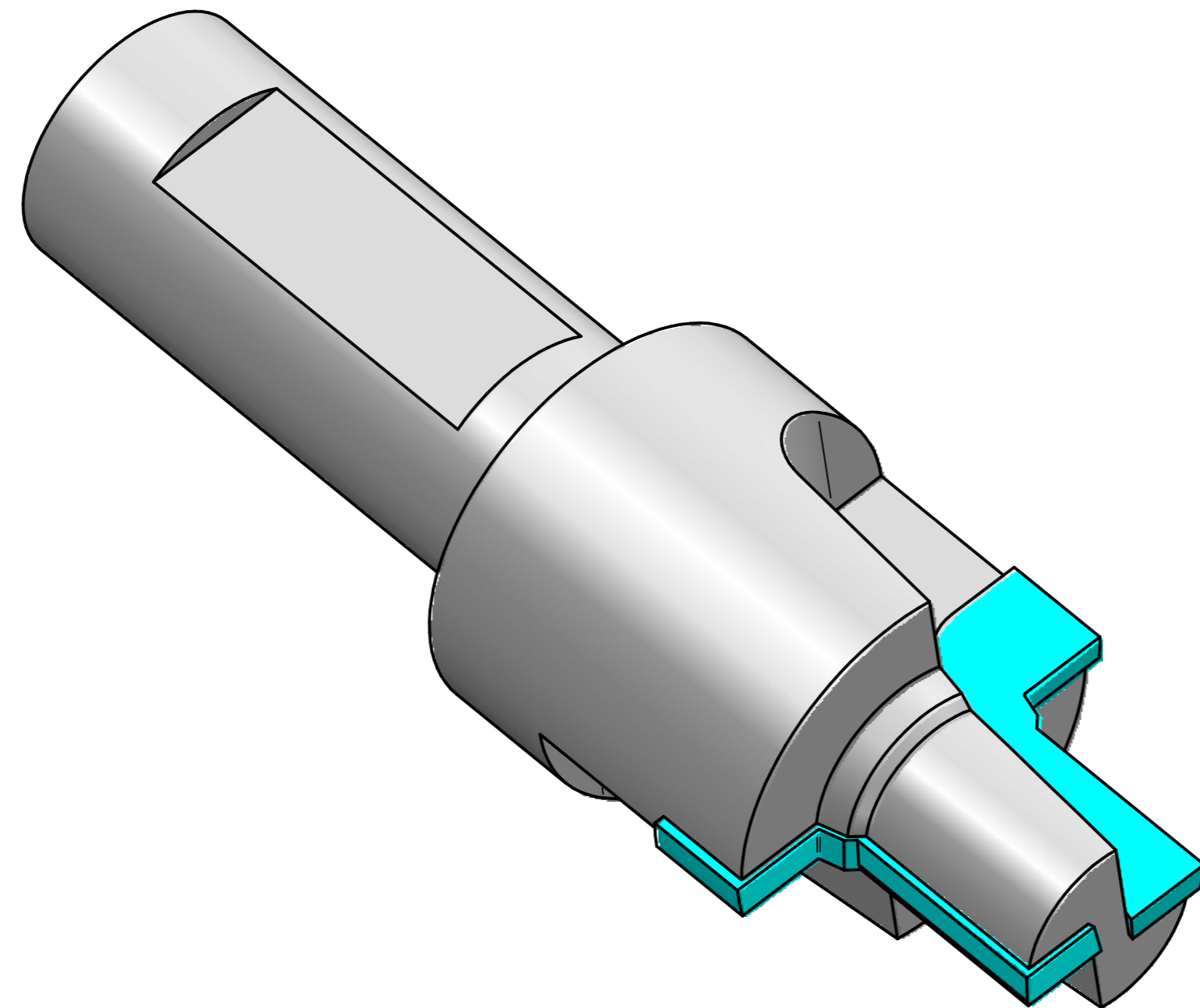

SAE10 Bar

	NAME	DATE	PREMAC	
DRAWN	Dan	10/15/19		
APPROVED			TITLE	
MATERIAL				
TREATMENT				
UNLESS OTHERWISE SPECIFIED DIMENSIONS ARE IN MILLIMETERS			SIZE A4	DWG NO
1 ST ANGLE  2 PL ±0.02 3 PL ±0.005			FILE NAME: SAE10x25.dft	REV
			SCALE:	WEIGHT:
			SHEET 2 OF 2	