

REVISION HISTORY			
REV	DESCRIPTION	DATE	APPROVED

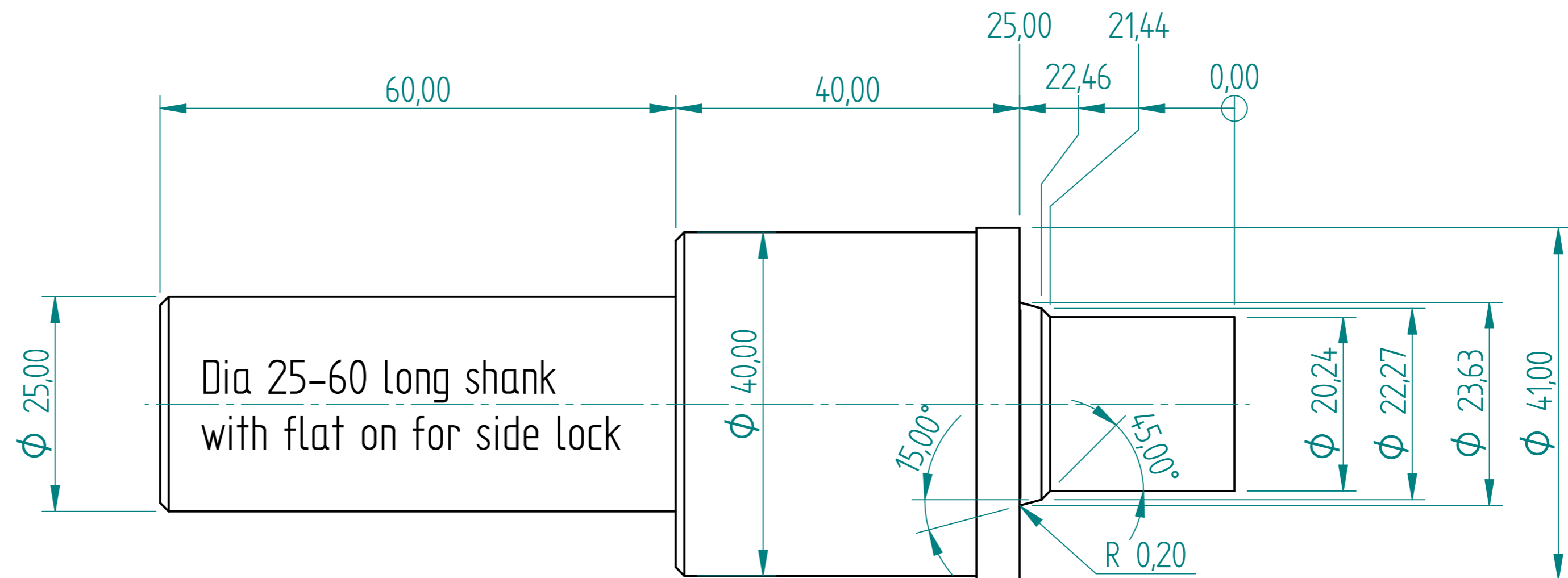
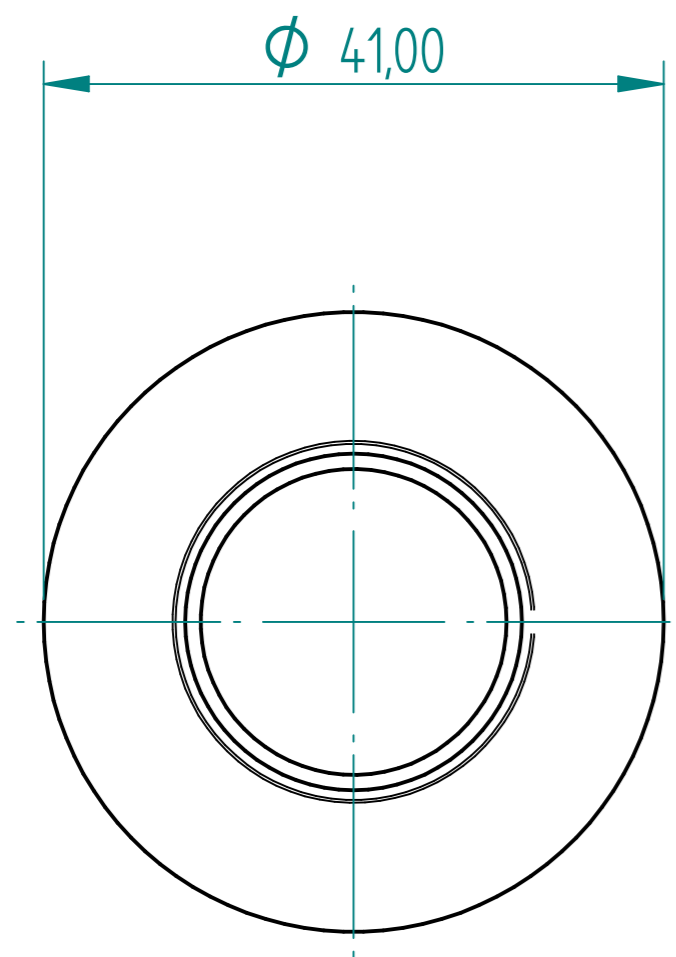

TO CUT CAVITY FOR SAE-10 BY 25mm DEEP IN CAST IRON

SAE-10 by 25 mm DEEP

	NAME	DATE	PREMAC	
DRAWN	Dan	10/15/19		
APPROVED			TITLE	
MATERIAL				
TREATMENT				
UNLESS OTHERWISE SPECIFIED DIMENSIONS ARE IN MILLIMETERS			SIZE A4	DWG NO
1 ST ANGLE ANGLES $\pm 0,1^\circ$			FILE NAME: SAE10x25.dft	
2 PL $\pm 0,02$ 3 PL $\pm 0,005$			SCALE:	WEIGHT:
			SHEET 1 OF 1	