

REVISION HISTORY			
REV	DESCRIPTION	DATE	APPROVED

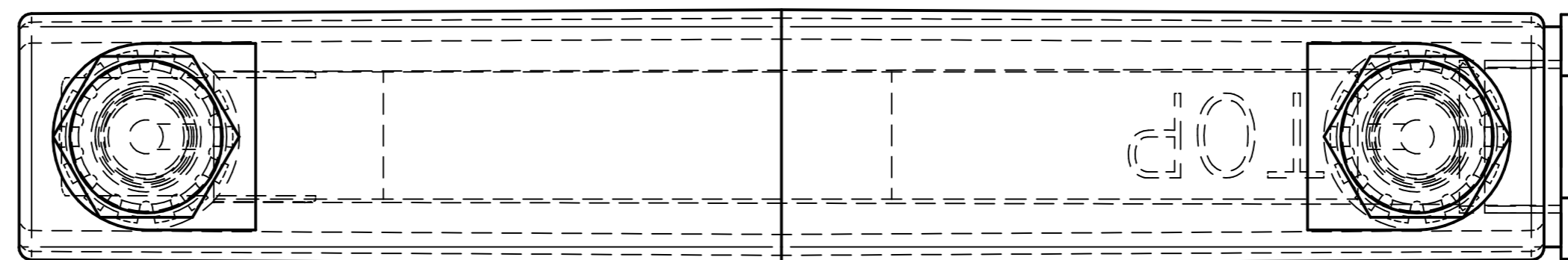
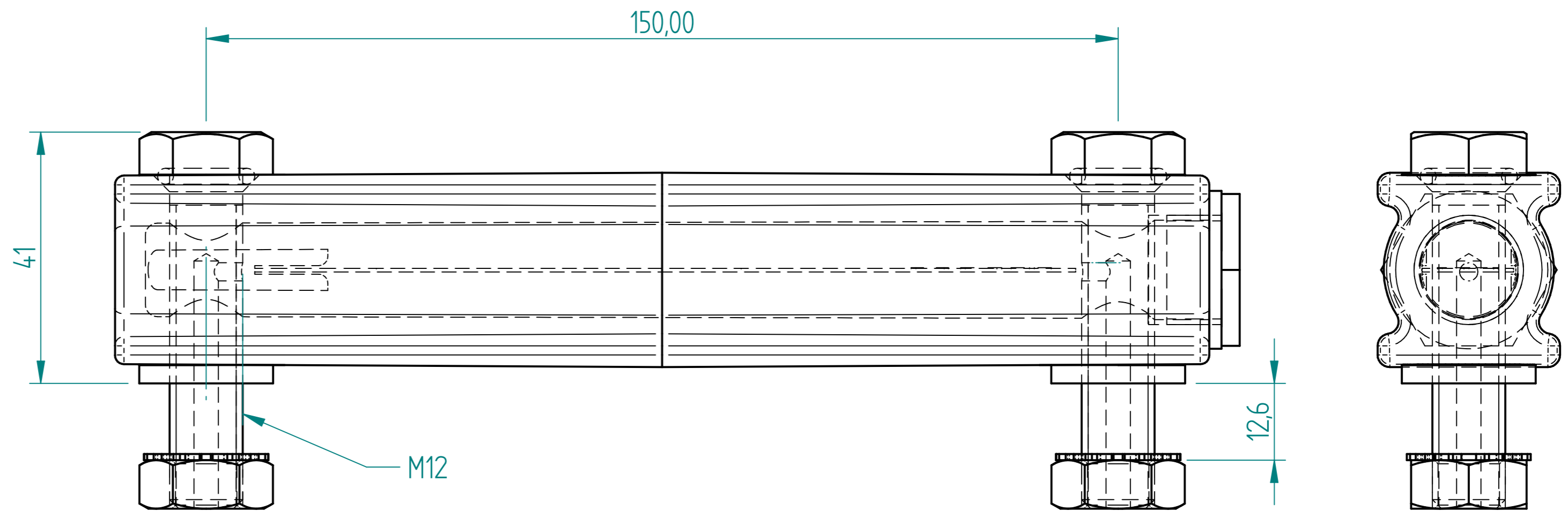
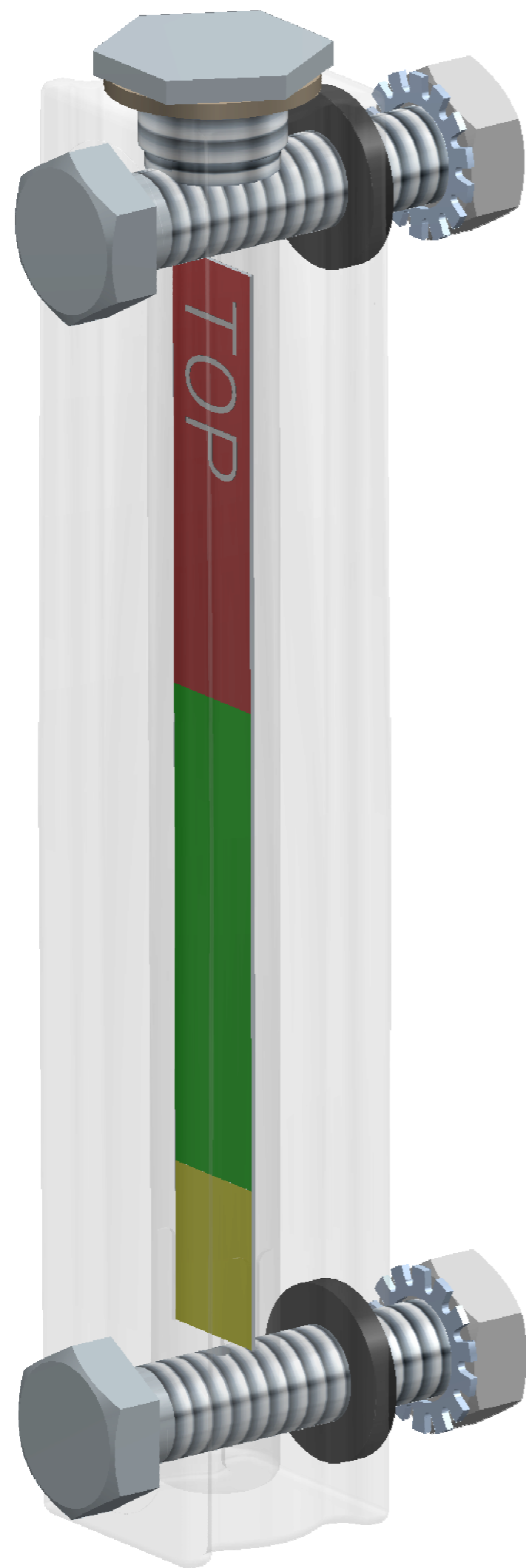

150mm Tank Sight Glass

DRAWN	NAME	DATE	PREMAC		
APPROVED	Dan	09/04/23			
MATERIAL			TITLE		
TREATMENT			150 Sight Glass		
UNLESS OTHERWISE SPECIFIED DIMENSIONS ARE IN MILLIMETERS			SIZE	DWG NO	REV
1 st ANGLE			A4	SG -150	
2 PL ±0.02 3 PL ±0.005			FILE NAME: 150 Sight Glass.dft		
			SCALE:	WEIGHT:	SHEET 1 OF 7

REVISION HISTORY			
REV	DESCRIPTION	DATE	APPROVED

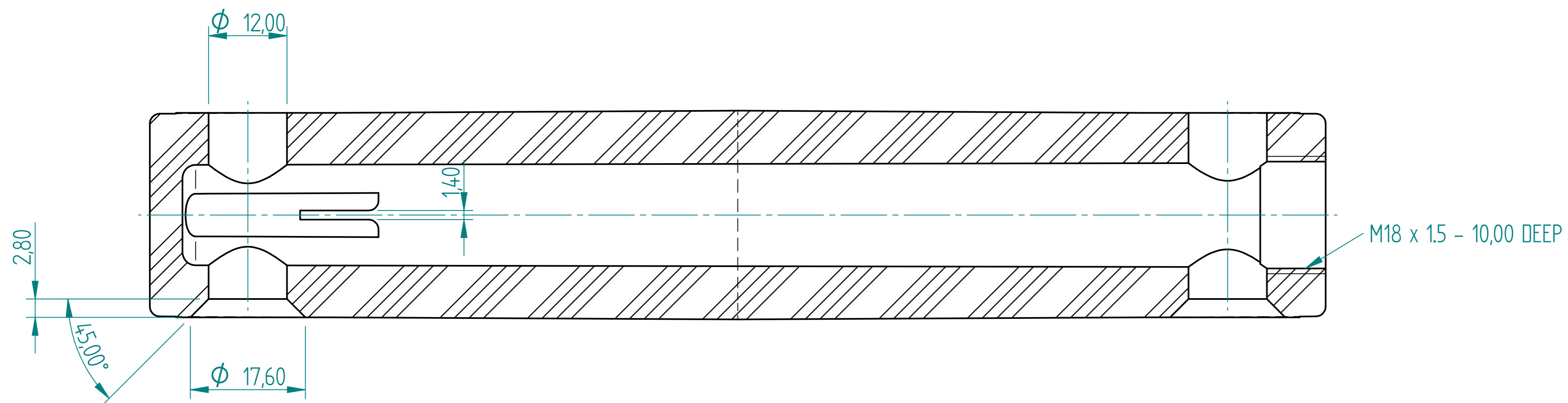
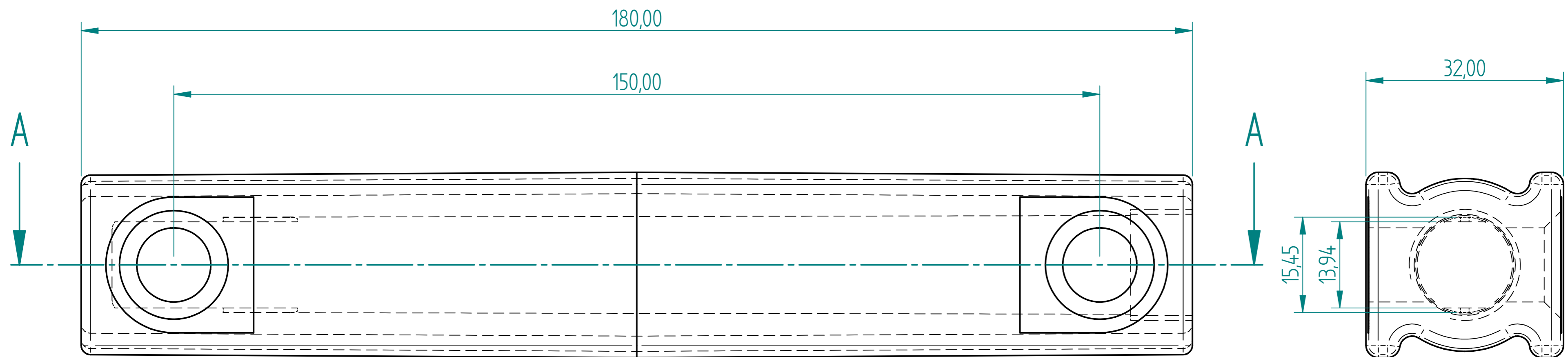

SECTION A-A

DRAWN	NAME	DATE	PREMAC			
APPROVED	Dan	09/04/23				
MATERIAL					TITLE	150 Sight Glass
TREATMENT					SIZE	A4
UNLESS OTHERWISE SPECIFIED DIMENSIONS ARE IN MILLIMETERS			DWG NO	SG -150	REV	
1 st ANGLE 2 PL ±0.02 3 PL ±0.005			FILE NAME:	150 Sight Glass.dft		
			SCALE:	WEIGHT:	SHEET 2 OF 7	

REVISION HISTORY			
REV	DESCRIPTION	DATE	APPROVED

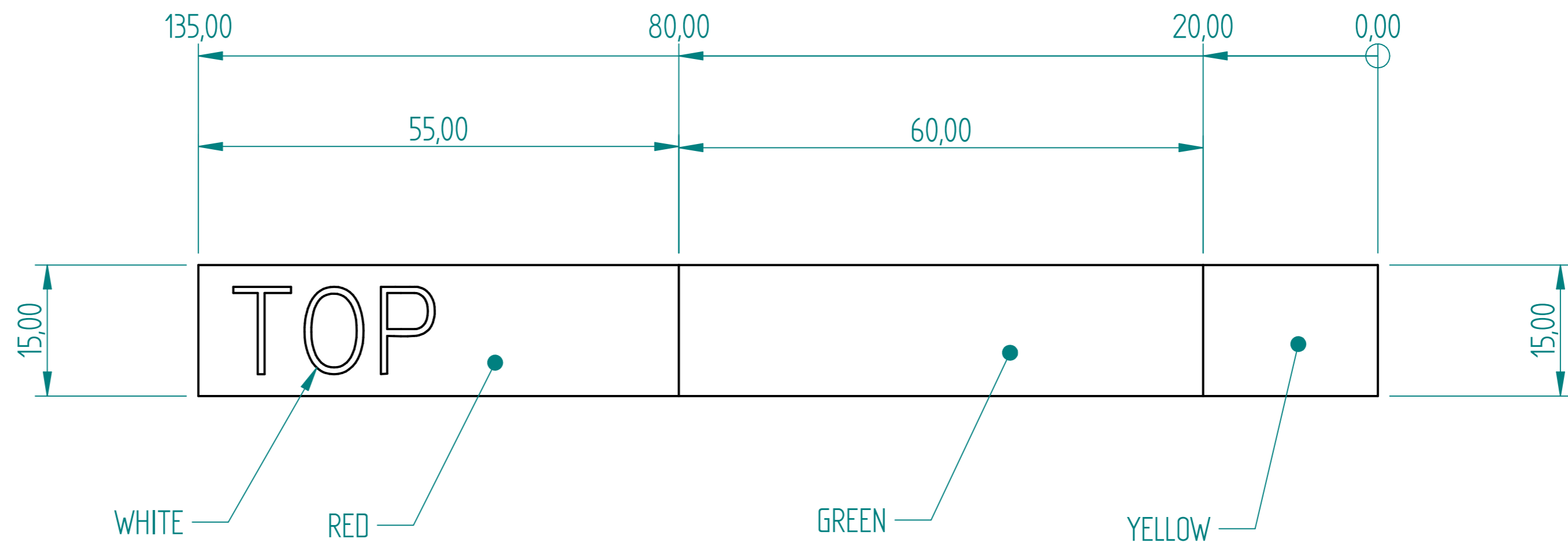

CARD
1 mm ABS

	NAME	DATE	PREMAC	
DRAWN	Dan	09/04/23		
APPROVED				
MATERIAL				
TREATMENT			TITLE	150 Sight Glass
UNLESS OTHERWISE SPECIFIED DIMENSIONS ARE IN MILLIMETERS			SIZE	DWG NO
1 st ANGLE			A4	SG -150
2 PL ±0.02 3 PL ±0.005			FILE NAME: 150 Sight Glass.dft	REV
			SCALE:	WEIGHT:
			SHEET 3 OF 7	

REVISION HISTORY			
REV	DESCRIPTION	DATE	APPROVED

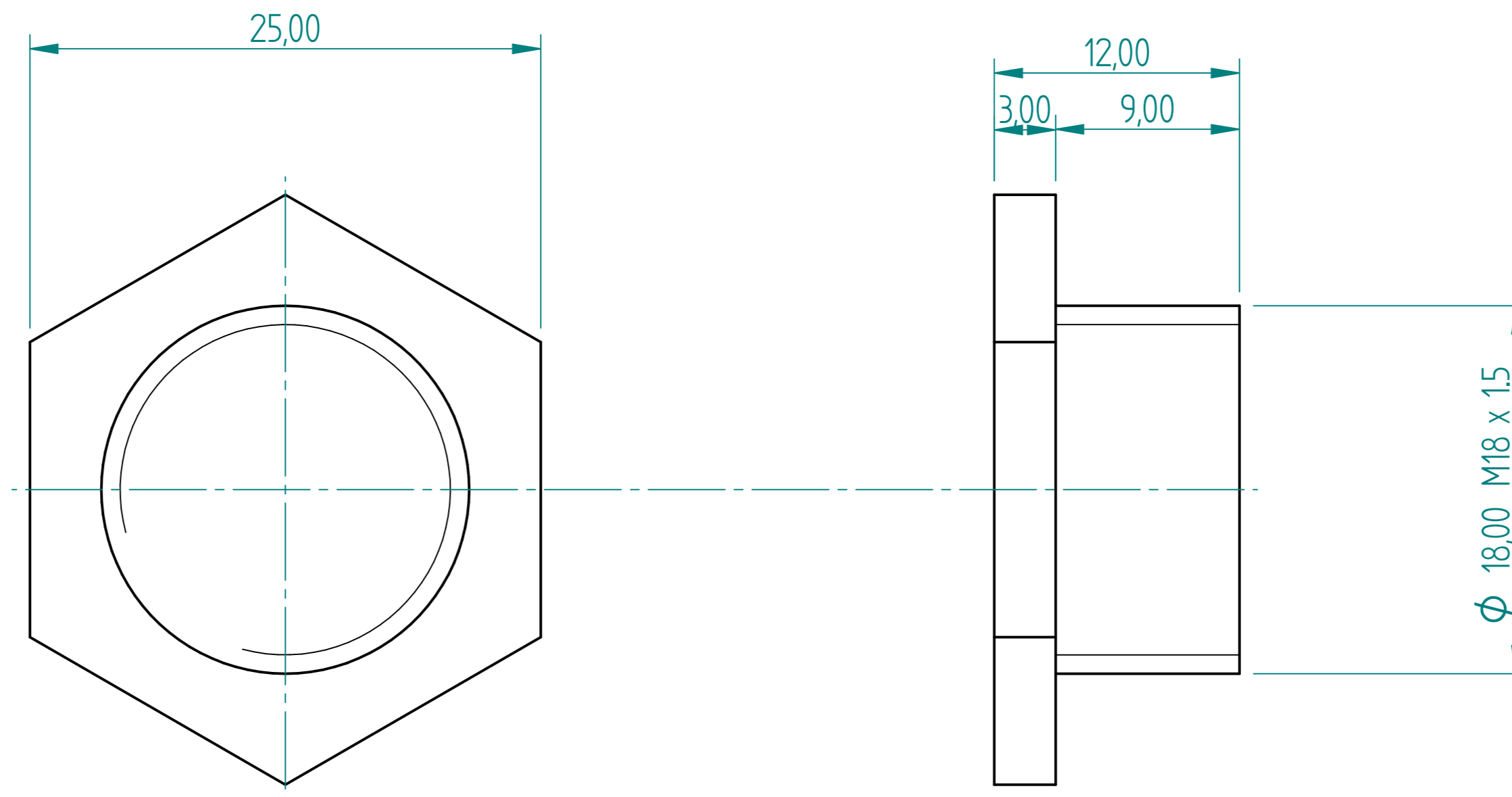

Bolt M18-1.5

	NAME	DATE	PREMAC	
DRAWN	Dan	09/04/23		
APPROVED				
MATERIAL				
TREATMENT			TITLE	150 Sight Glass
UNLESS OTHERWISE SPECIFIED DIMENSIONS ARE IN MILLIMETERS			SIZE	DWG NO
1 st ANGLE			A4	SG -150
2 PL ±0.02 3 PL ±0.005			FILE NAME: 150 Sight Glass.dft	REV
			SCALE:	WEIGHT:
				SHEET 4 OF 7

REVISION HISTORY			
REV	DESCRIPTION	DATE	APPROVED

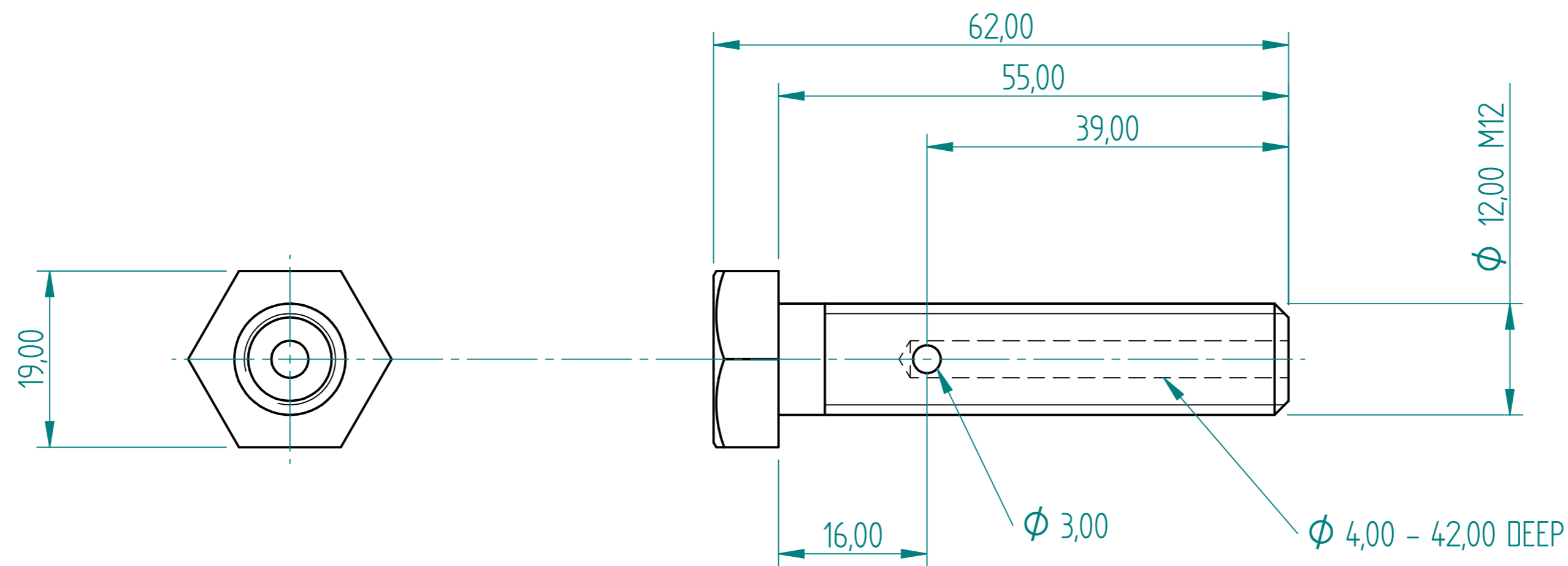

Bolt M12

	NAME	DATE	PREMAC	
DRAWN	Dan	09/04/23		
APPROVED				
MATERIAL				
TREATMENT			TITLE	150 Sight Glass
UNLESS OTHERWISE SPECIFIED DIMENSIONS ARE IN MILLIMETERS			SIZE A4	DWG NO SG -150
1 st ANGLE 2 PL ±0.02 3 PL ±0.005			FILE NAME: 150 Sight Glass.dft	REV
			SCALE:	WEIGHT:
			SHEET 5 OF 7	

REVISION HISTORY			
REV	DESCRIPTION	DATE	APPROVED

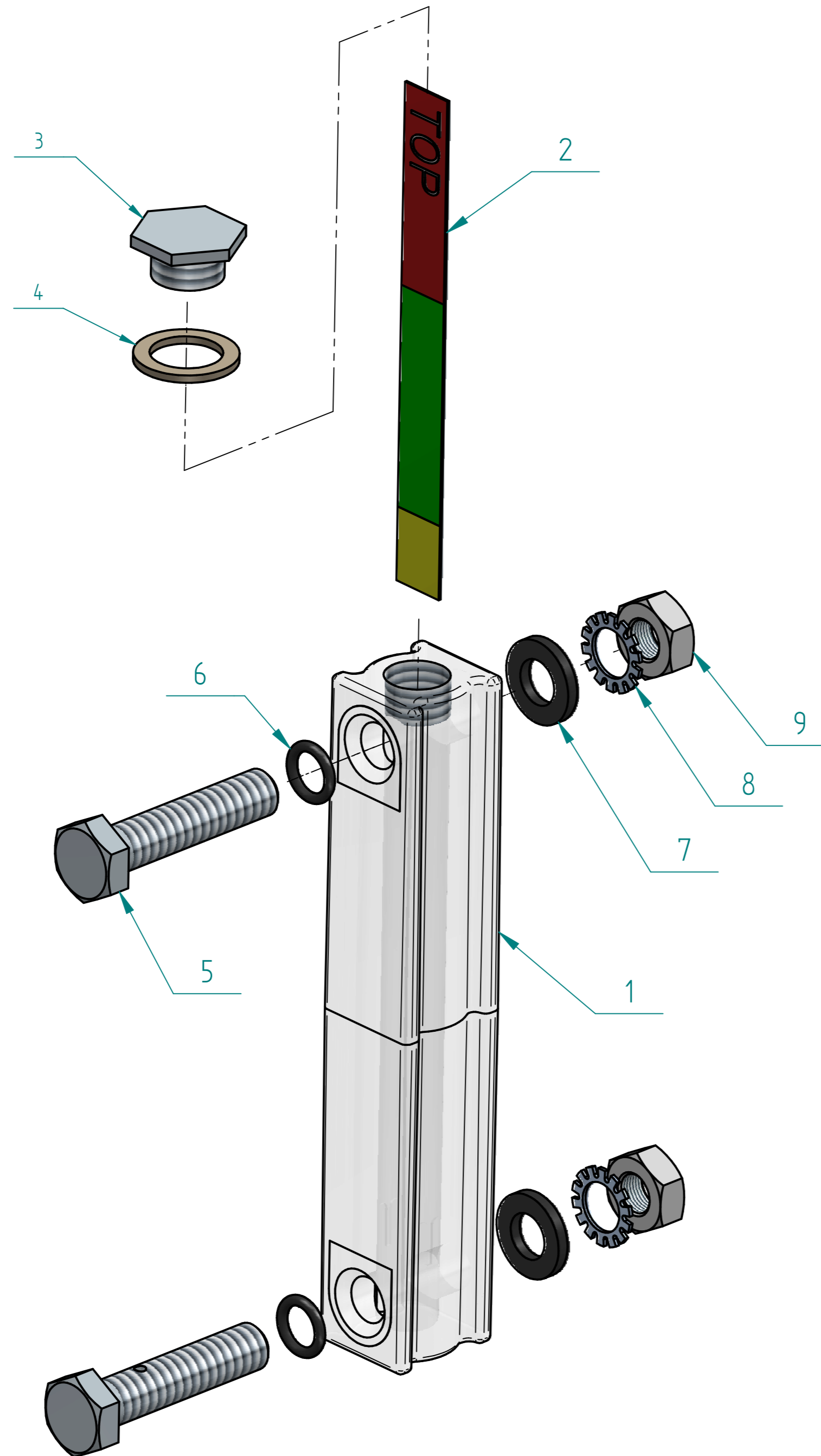

Item Number	Title	Document Number	Quantity
1	Sight Glass	SG -150 Housing	1
2	CARD	SG-150 Card	1
3	Bolt M18-1.5	M18x1.5 -9	1
4	Top Seal	S ID 18-2	1
5	Bolt M12	M12 -55	2
6	O-Ring	2-111	2
7	Tank Seal	S ID 12-3	2
8	Spring Washer	M12	2
9	Nut	M12	2

	NAME	DATE	PREMAC	
DRAWN	Dan	09/04/23		
APPROVED				
MATERIAL				
TREATMENT			TITLE	150 Sight Glass
UNLESS OTHERWISE SPECIFIED DIMENSIONS ARE IN MILLIMETERS			SIZE	DWG NO
ANGLES ±0.1°			A4	SG -150
1st ANGLE			FILE NAME: 150 Sight Glass.dft	
2 PL ±0.02 3 PL ±0.005			SCALE:	WEIGHT:
			SHEET 6 OF 7	

REVISION HISTORY			
REV	DESCRIPTION	DATE	APPROVED

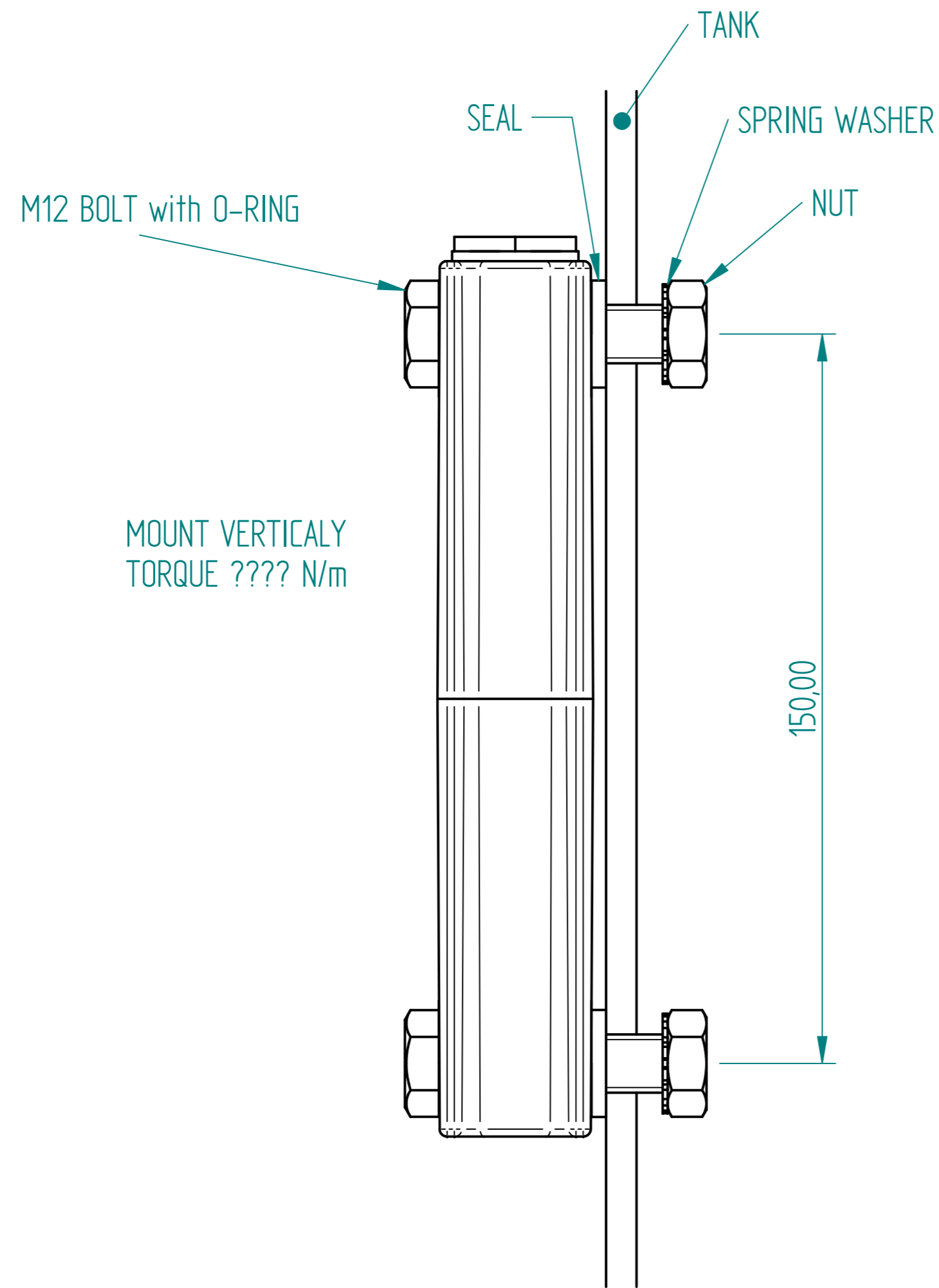

	NAME	DATE	PREMAC	
DRAWN	Dan	09/04/23		
APPROVED				
MATERIAL				
TREATMENT			TITLE	150 Sight Glass
UNLESS OTHERWISE SPECIFIED DIMENSIONS ARE IN MILLIMETERS			SIZE	DWG NO
1 st ANGLE			A4	SG -150
ANGLES ±0,1°			FILE NAME: 150 Sight Glass.dft	
2 PL ±0.02 3 PL ±0.005			SCALE:	WEIGHT:
			SHEET 7 OF 7	