

REVISION HISTORY			
REV	DESCRIPTION	DATE	APPROVED

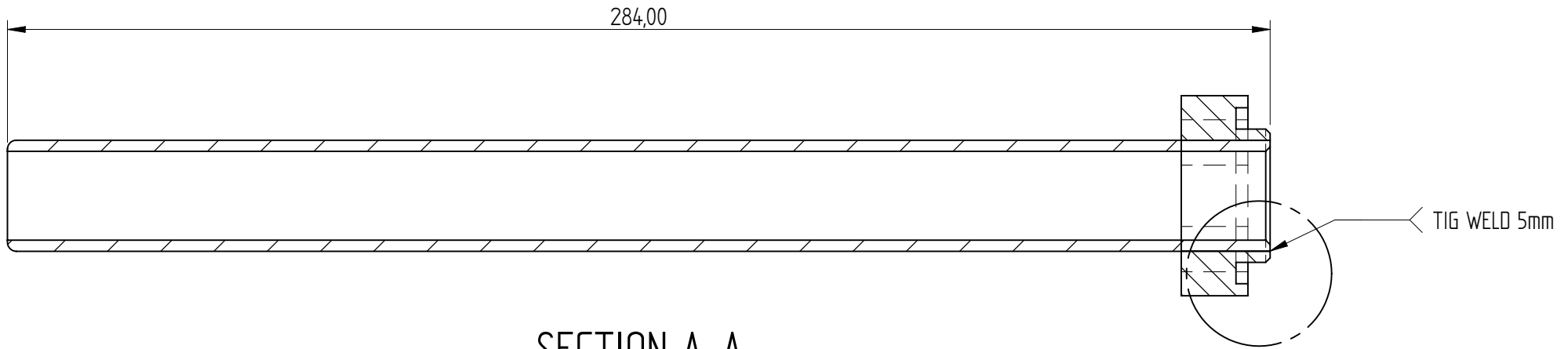

SECTION A-A

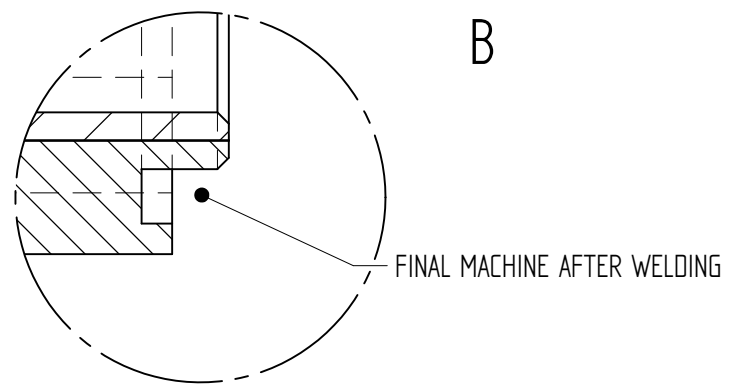
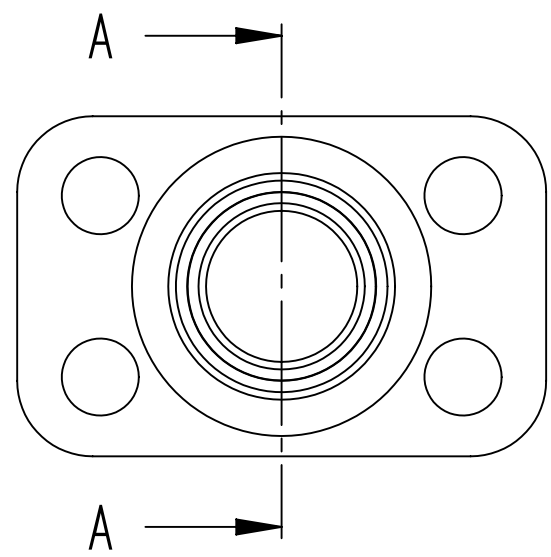

DETAIL B

	NAME	DATE	HYDROFLOOR MANUFACTURING (PTY) LTD	
DRAWN	Dan	04/12/08	TITLE NEEDLE FLANGE ASS	
APPROVED			SIZE A2	DWG NO RW-10-00-01
MATERIAL			FILE NAME: RW-10-00-01.dft	REV
TREATMENT			SCALE:	WEIGHT:
UNLESS OTHERWISE SPECIFIED DIMENSIONS ARE IN MILLIMETERS ANGLES ±0.1°			2 PL ±0.02	3 PL ±0.005
1:1 ANGLE			SHEET 1 OF 1	