

REVISION HISTORY			
REV	DESCRIPTION	DATE	APPROVED

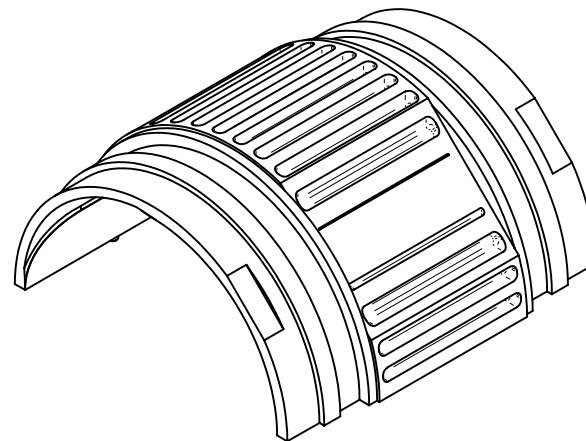
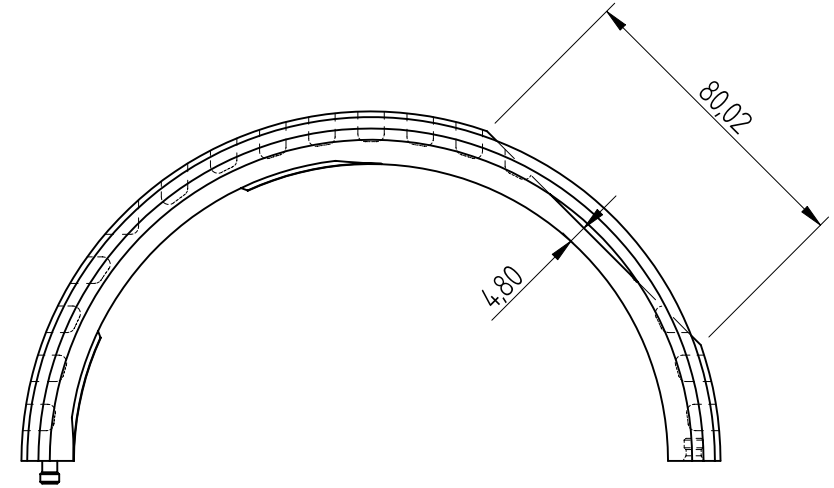
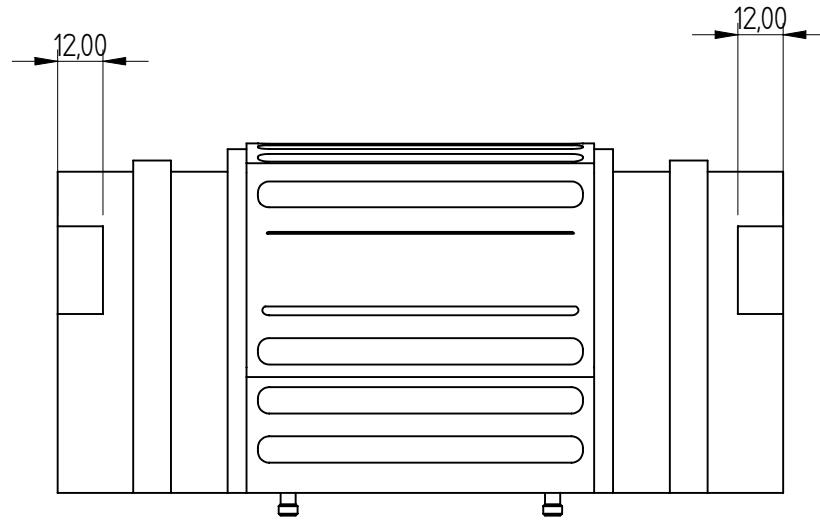

	NAME	DATE	HYDROFLOOR	
DRAWN	Dan	04/12/08	MANUFACTURING (PTY) LTD	
APPROVED			TITLE	
MATERIAL			UPPER EXT SLEEVE 1/3	
TREATMENT			SIZE	DWG NO
			A2	RW-09-01-01
			FILE NAME:	REV
			RW-09-01-01.dft	
UNLESS OTHERWISE SPECIFIED DIMENSIONS ARE IN MILLIMETERS ANGLES ±0,1°			SCALE:	WEIGHT:
1:1 SCALE	2 PL ±0.02	3 PL ±0.005		SHEET 1 OF 1