

| REVISION HISTORY |             |      |          |
|------------------|-------------|------|----------|
| REV              | DESCRIPTION | DATE | APPROVED |
|                  |             |      |          |

NOTES:

ACME 4 T.P.I.  
 29 DEG TOOTH PROFILE  
 PITCH = 6.35 mm  
 THREAD HIEGHT = 3.429mm

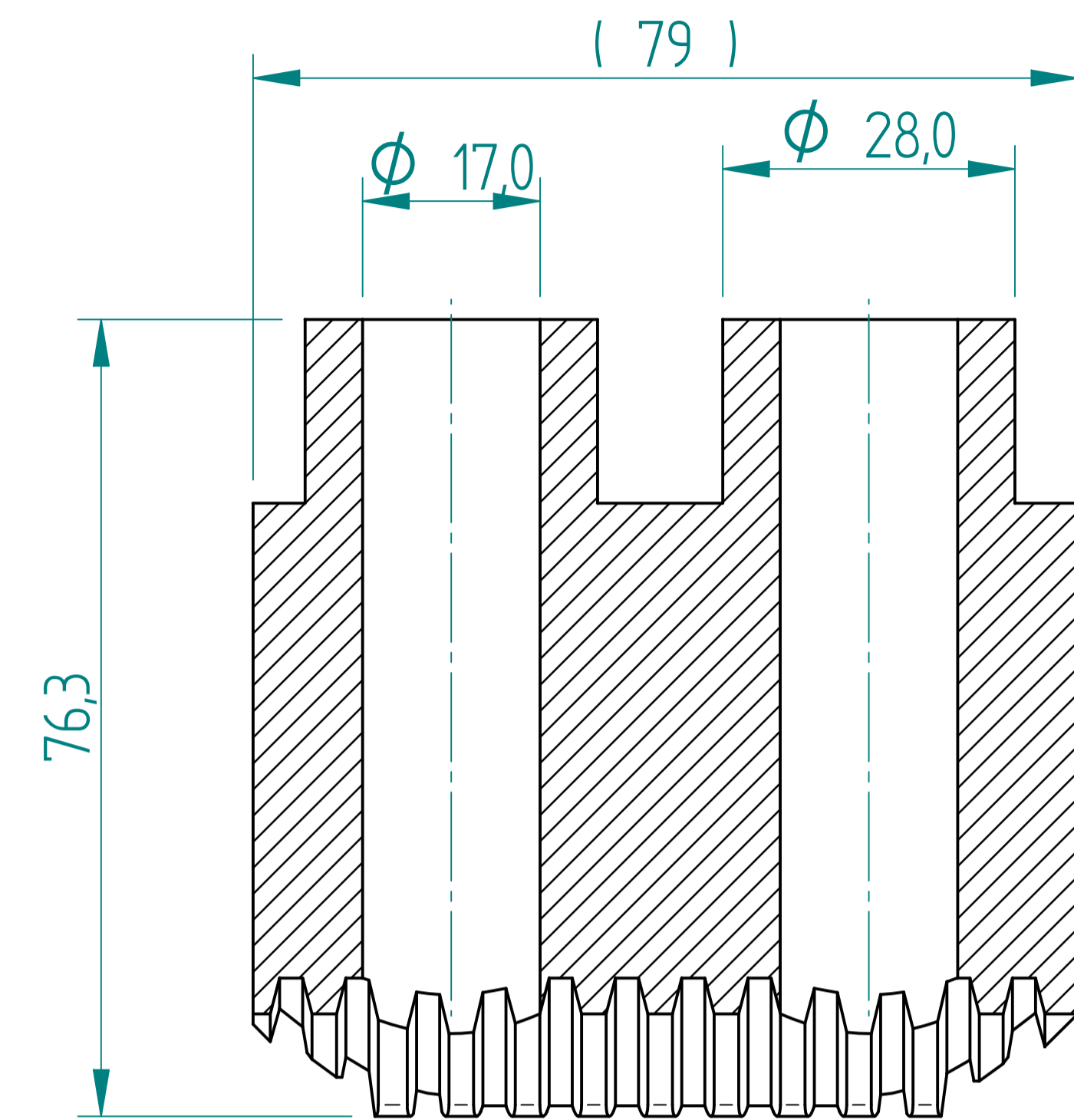
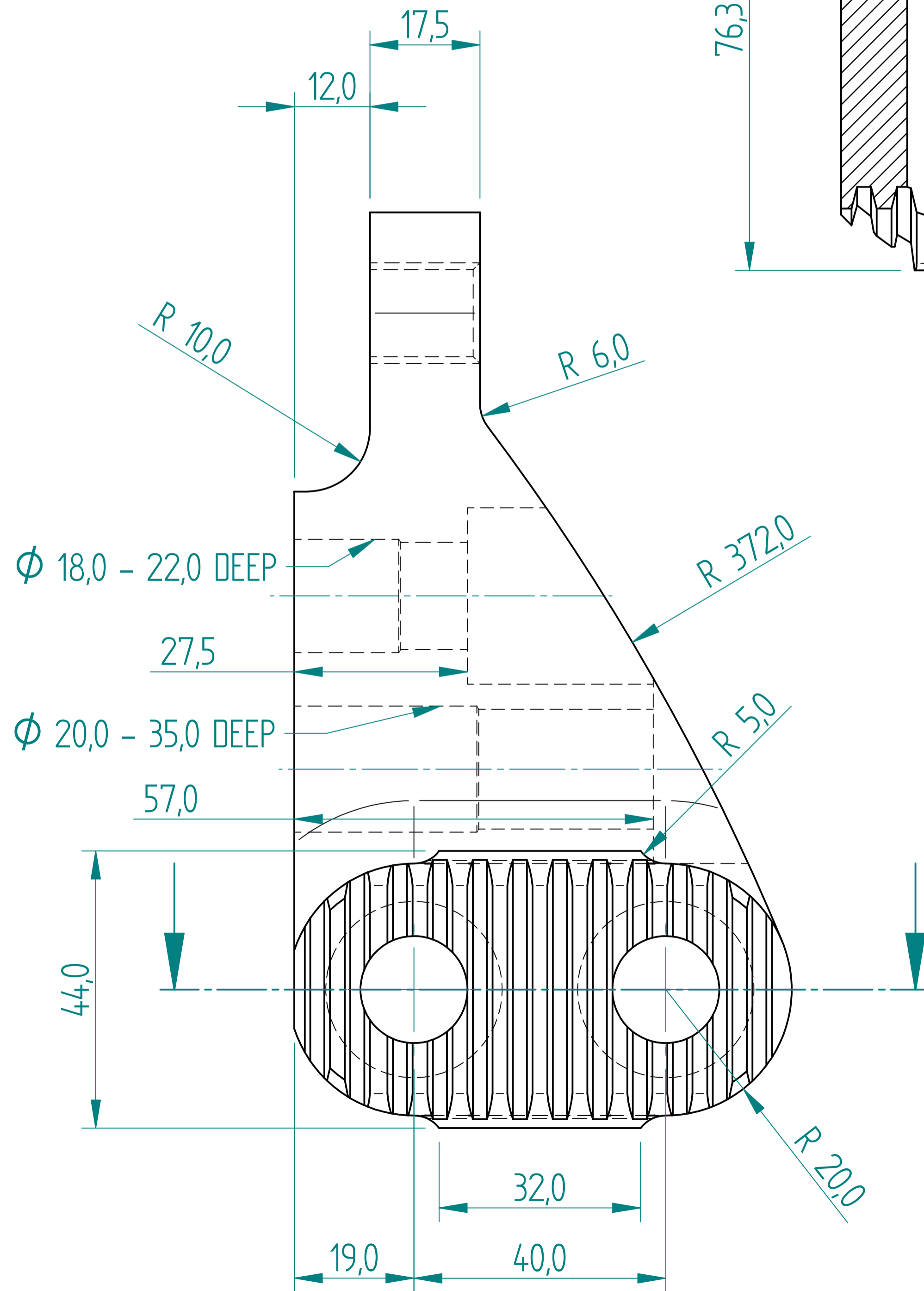
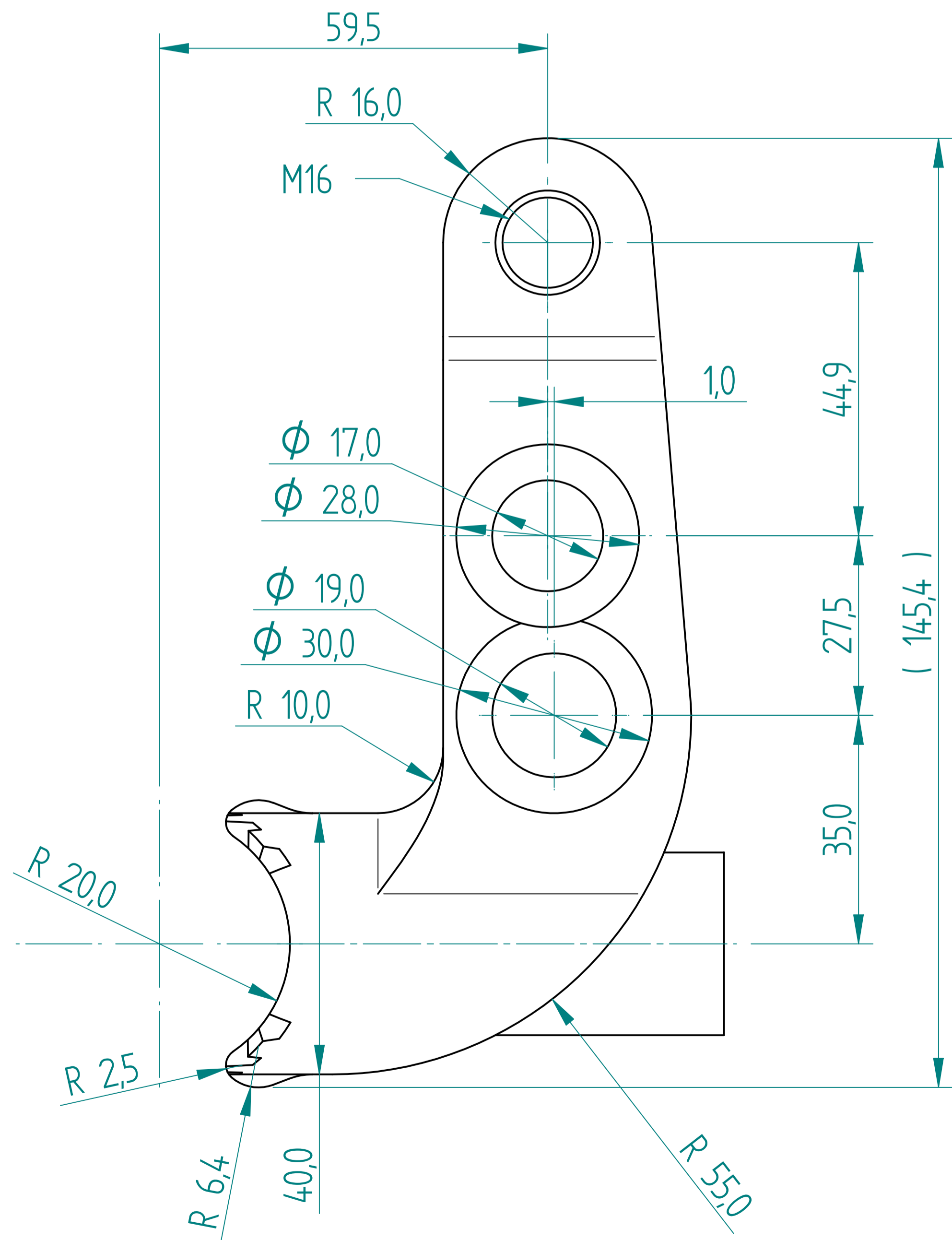

SECTION A-A

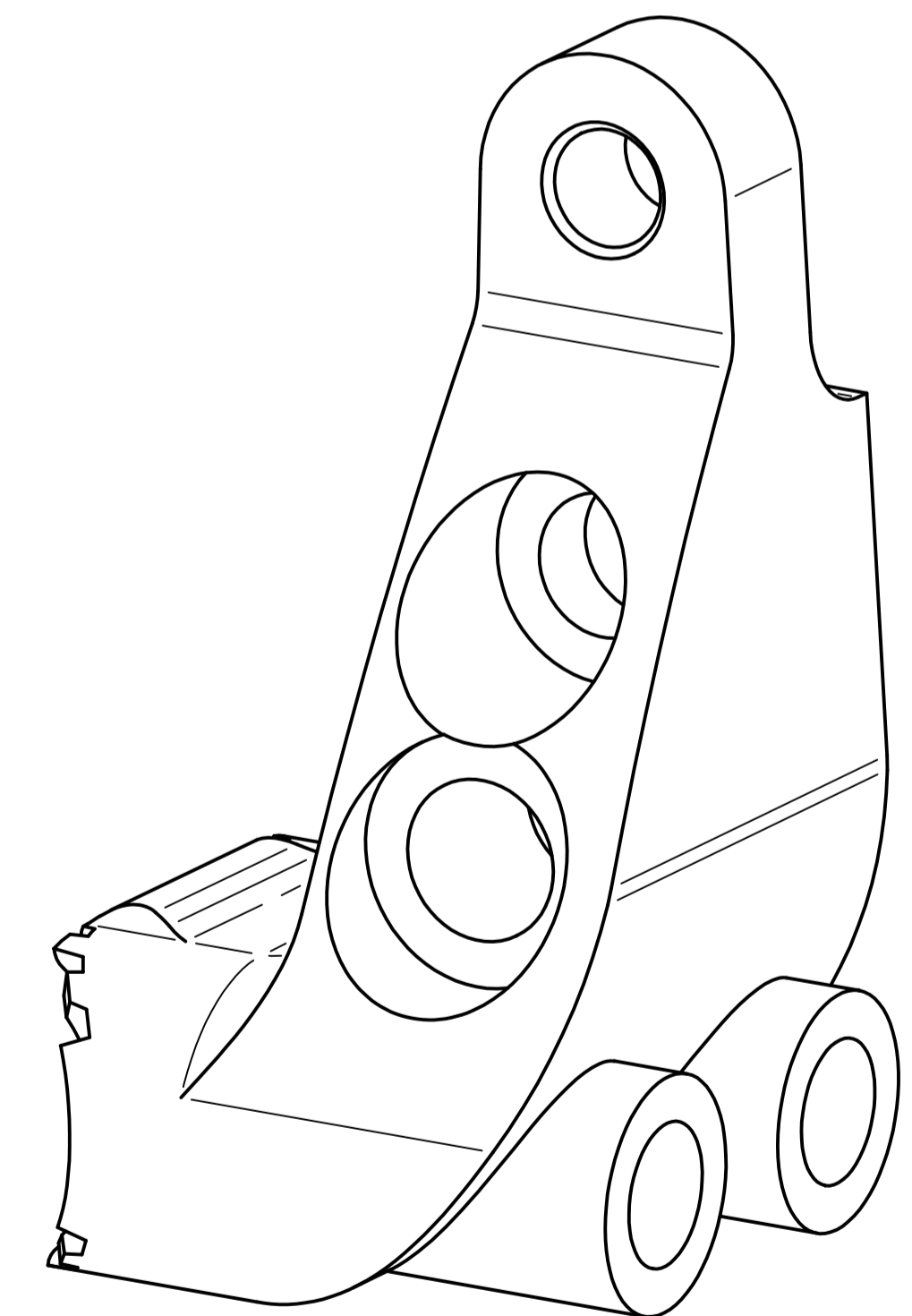

| NAME  | DATE     | HYDROFLOOR MANUFACTURING (PTY) LTD |                    |
|---|----------|------------------------------------|--------------------|
| DRAWN Dan   | 03/04/10 | TITLE WING OUTER R.H.S.            |                    |
| APPROVED  |          | SIZE A2                            | DWG NO RW-05-00-01 |
| MATERIAL  |          | FILE NAME RW-05-00-01.dft          | REV                |
| TREATMENT   |          | SCALE                              | WEIGHT             |
| UNLESS OTHERWISE SPECIFIED DIMENSIONS ARE IN MILLIMETERS ANGLES ±0.1° |          | 2 PL ±0.02                         | 3 PL ±0.005        |
| 1:1 ANGLE   |          | SHEET 1 OF 1                       |                    |