

REVISION HISTORY			
REV	DESCRIPTION	DATE	APPROVED

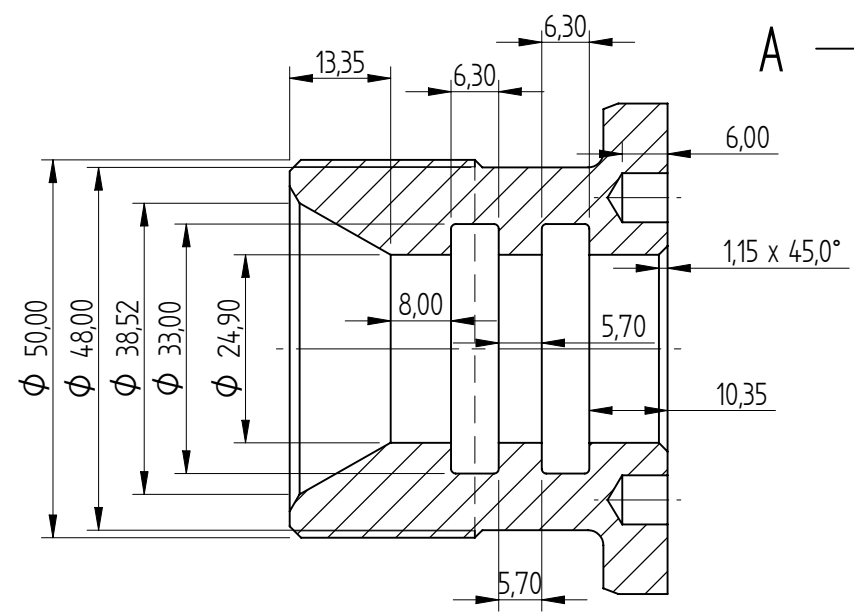

SECTION A-A

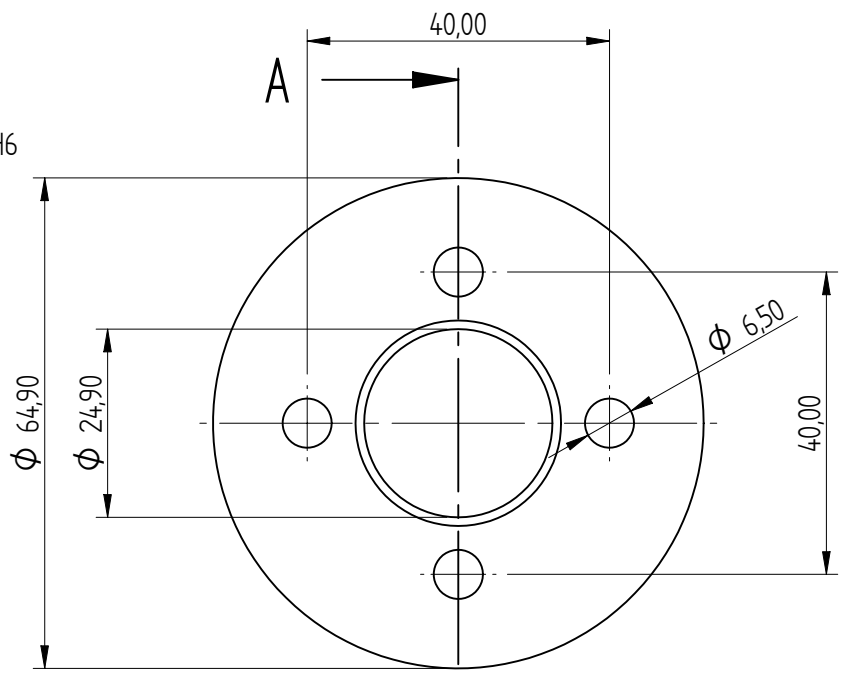
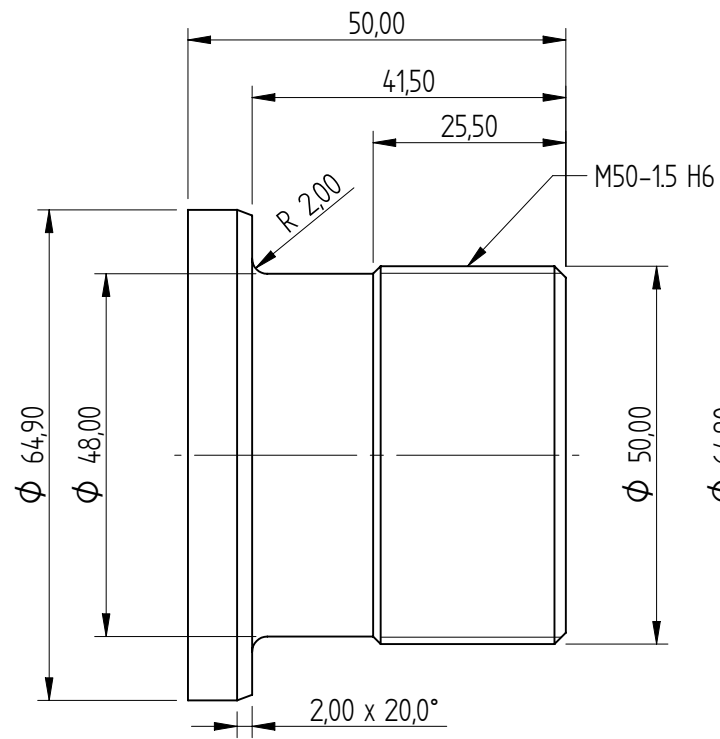
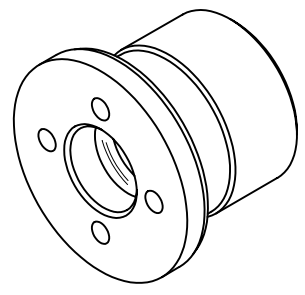

MATERIAL TO BE DECIDED ALU BRONZE OR CAST IRON

DRAWN	NAME	DATE	HYDROFLOOR MANUFACTURING (PTY) LTD	
APPROVED	Dan	04/12/08	TITLE	
MATERIAL			GLAND NUT	
TREATMENT			SIZE	DWG NO
UNLESS OTHERWISE SPECIFIED DIMENSIONS ARE IN MILLIMETERS ANGLES ±0,1°			A2	RW-02-05-01
			FILE NAME: RW-02-05-01.dft	REV
2 PL ±0,02 3 PL ±0,005			SCALE:	WEIGHT:
			SHEET 1 OF 1	