

REVISION HISTORY			
REV	DESCRIPTION	DATE	APPROVED

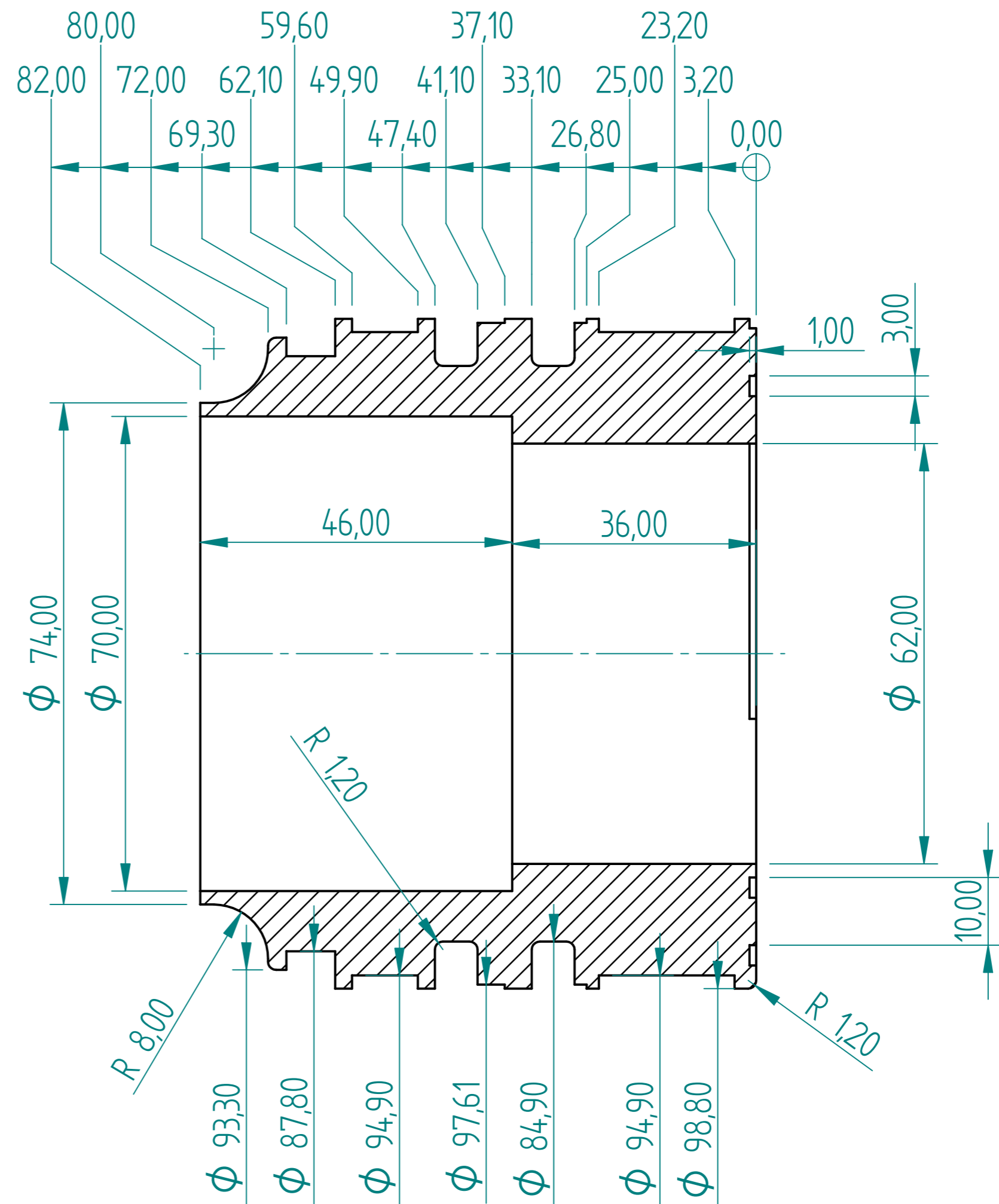
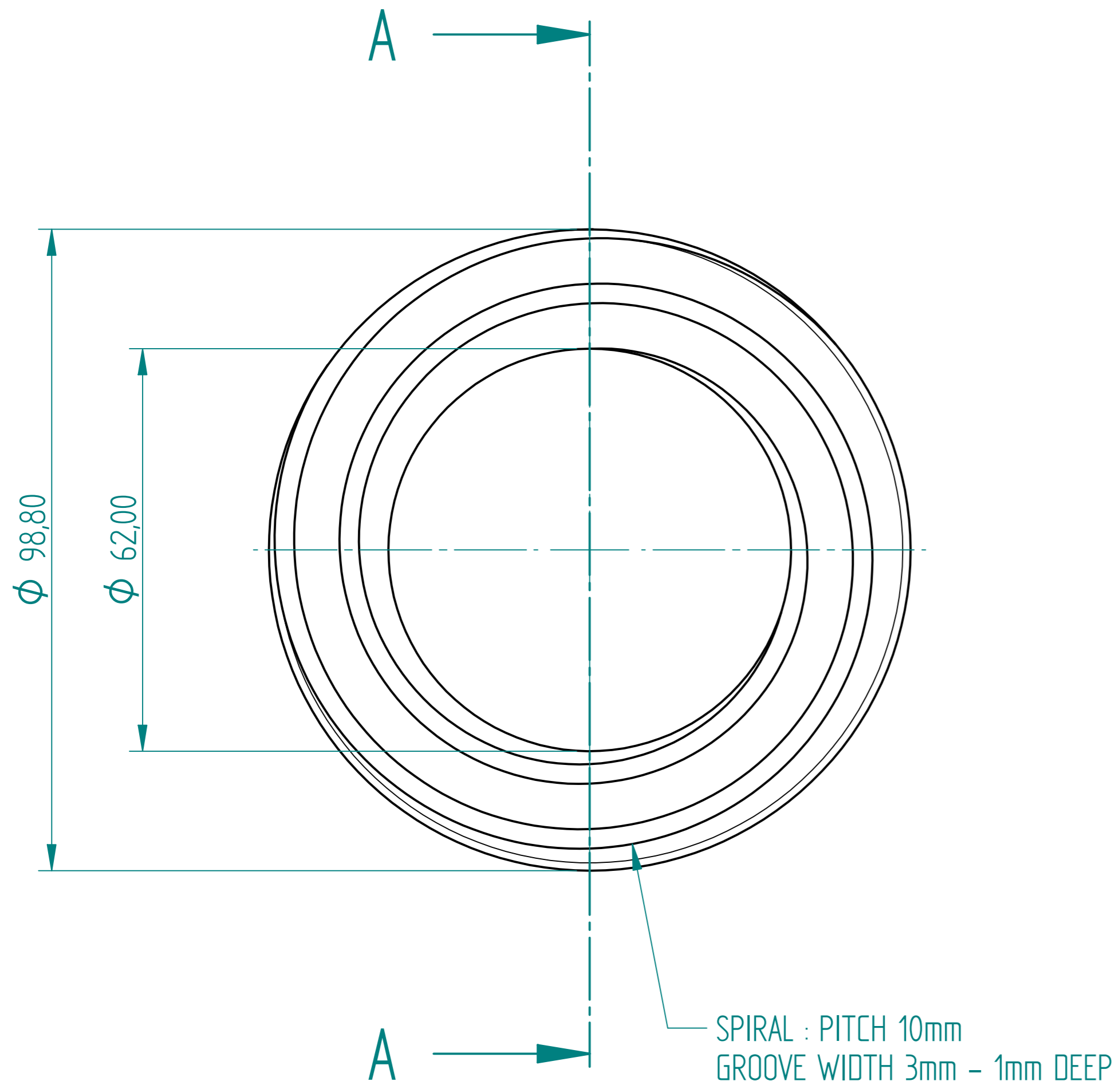

## SECTION A-A

	NAME	DATE	HYDROFLOOR MANUFACTURING (PTY) LTD	
DRAWN	Dan	03/11/10	TITLE	
APPROVED			PISTON SHAFT	
MATERIAL			SIZE	DWG NO
TREATMENT			A2	RW-02-04-00
UNLESS OTHERWISE SPECIFIED DIMENSIONS ARE IN MILLIMETERS			FILE NAME: RW-02-04-00.dft	REV
1 <sup>ST</sup> ANGLE 2 PL ±0.02 3 PL ±0.005			SCALE:	WEIGHT:
				SHEET 1 OF 1