

REVISION HISTORY			
REV	DESCRIPTION	DATE	APPROVED

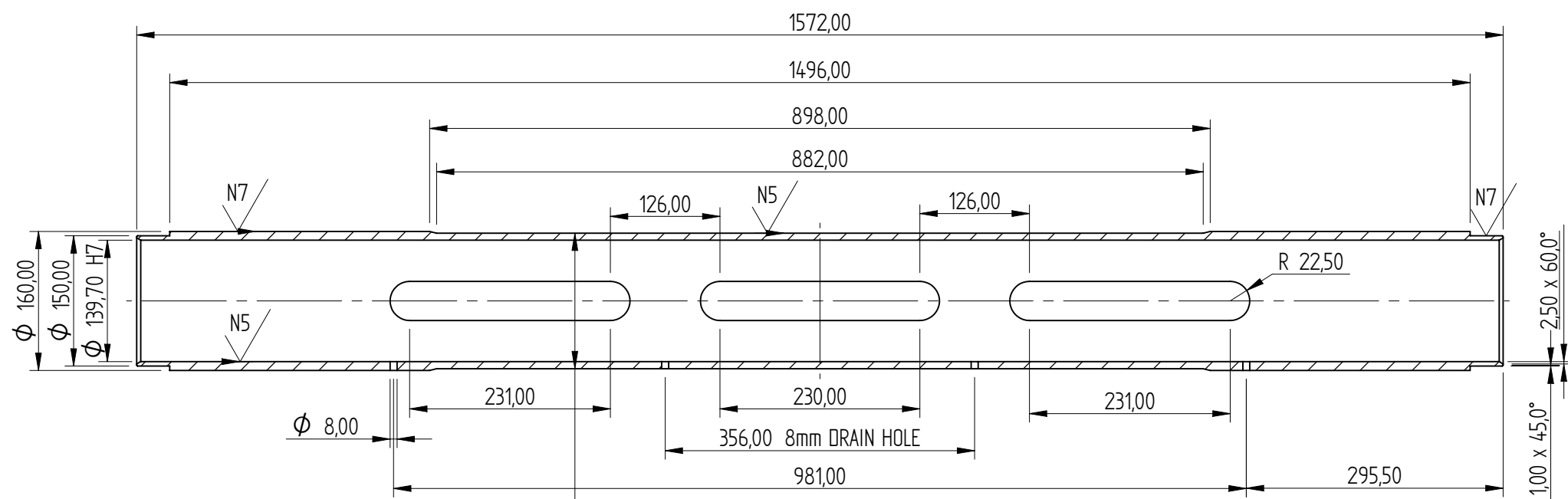

SECTION A-A

1. FINAL CYLINDER HONING TO BE COMPLETED PRIOR TO LASER CUTTING
2. FINAL MACHINE BEFORE LASER CUTTING THE 6 APERTURES
3. DEBURR THE LESER CUT PROFILE INSIDE AND OUTSIDE
4. PENCIL GRIND THE APERTURE PROFILE IN AND OUT R1 IN 6 PLACES

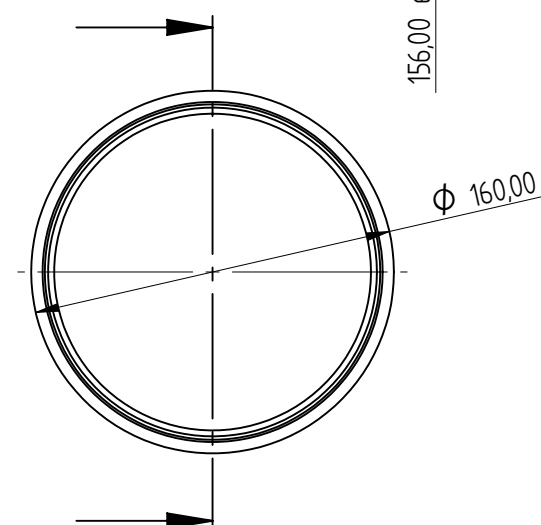

	NAME	DATE	HYDROFLOOR MANUFACTURING (PTY) LTD	
DRAWN	Dan	04/12/08	TITLE CYLINDER BARREL	
APPROVED			SIZE A2	DWG NO RW-01-01-03
MATERIAL			FILE NAME RW-01-01-03.dft	REV
TREATMENT			SCALE	WEIGHT
UNLESS OTHERWISE SPECIFIED DIMENSIONS ARE IN MILLIMETERS ANGLES ±0.1°			2 PL ±0.02	3 PL ±0.005
1:1 ANGLE			SHEET 1 OF 1	