

REVISION HISTORY			
REV	DESCRIPTION	DATE	APPROVED

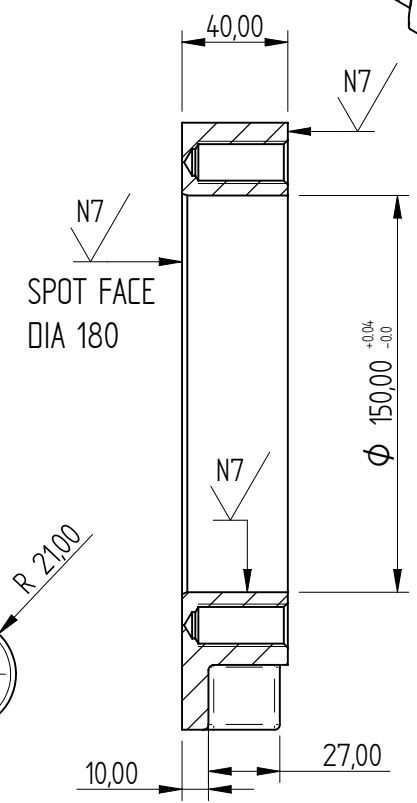
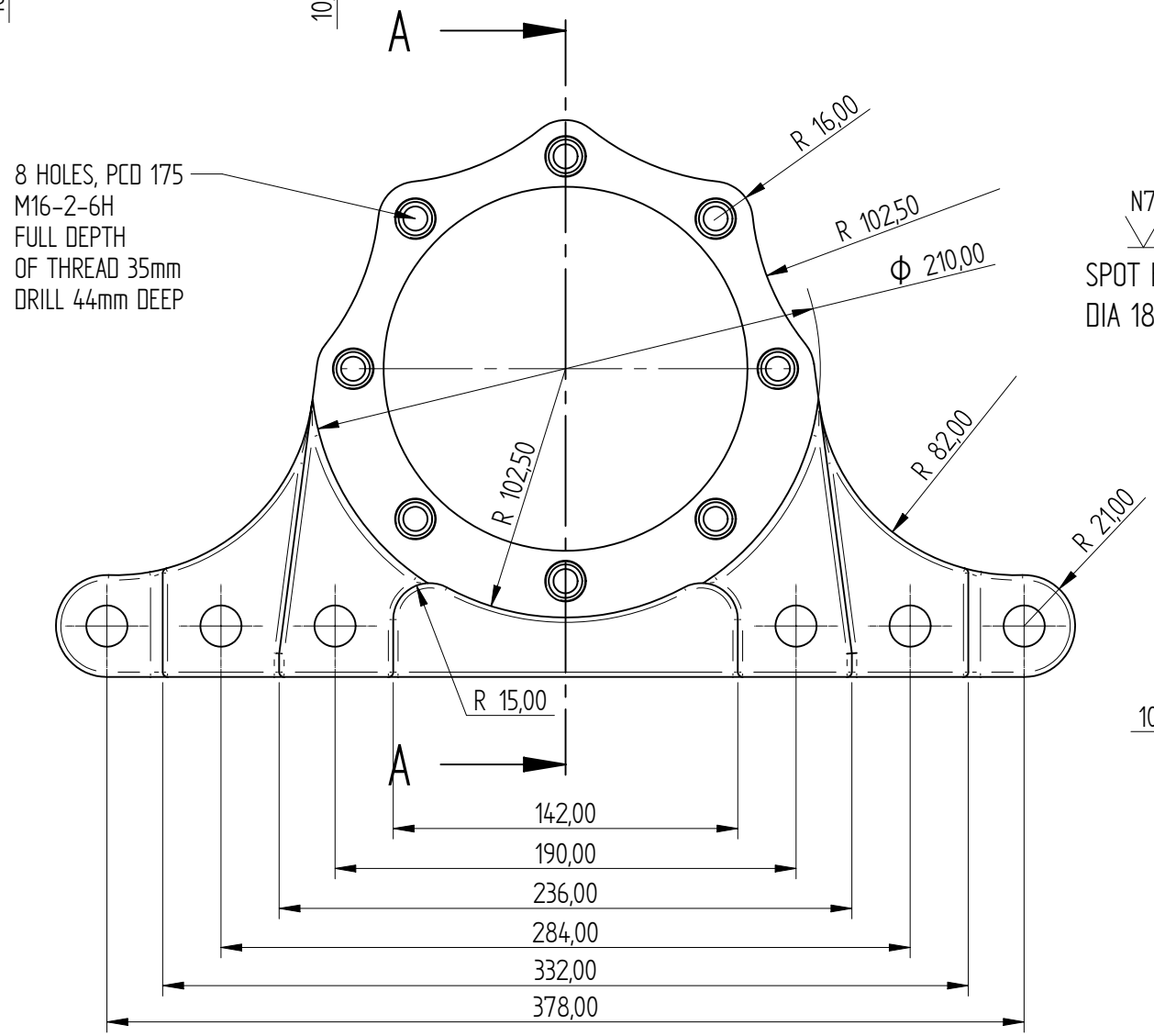
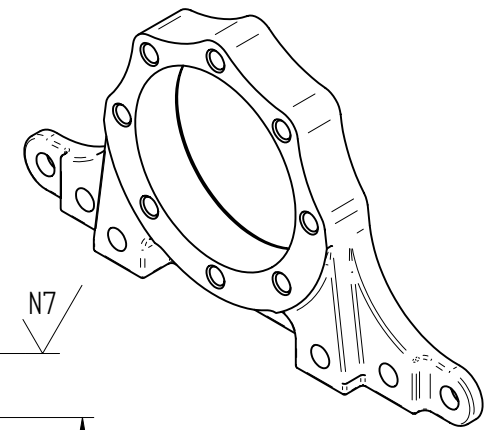
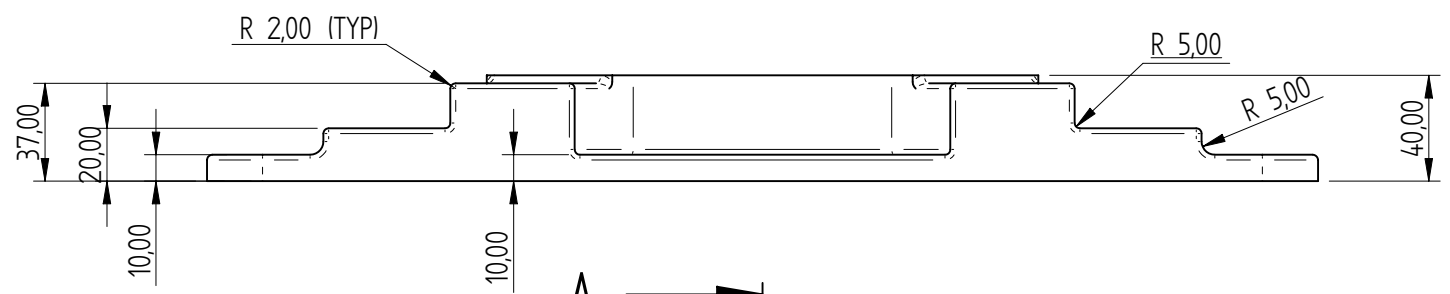

MASS 7-28Kg

SECTION A-A ADD DRAFT FOR CASTING AND 2.5mm FOR SPOT FACING

DRAWN	NAME	DATE	HYDROFLOOR MANUFACTURING (PTY) LTD	
APPROVED	Dan	04/12/08	TITLE	
MATERIAL			CYL END FLANGE	
TREATMENT			SIZE	DWG NO
UNLESS OTHERWISE SPECIFIED DIMENSIONS ARE IN MILLIMETERS ANGLES ±0.1°			A2	RW-01-01-02
			FILE NAME: RW-01-01-01.dft	REV
2 PL ±0.02 3 PL ±0.005			SCALE:	WEIGHT:
			SHEET 1 OF 1	