

UNLESS OTHERWISE SPECIFIED:		FINISH:		DRESS AND BREAK SHARP EDGES	
DIMENSIONS ARE IN MILLIMETERS					
TOLERANCES UNLESS OTHERWISE SPECIFIED:					
LINEAR:					
ANGULAR:					
DRAWN	NAME	SIGNATURE	DATE	TITLE:	
CHKD	Emil Hornhaga			DO NOT SCALE DRAWING	
APP'D	Rene Weglarup			REVISION	
MFG'G				B	
QA				A3	
MATERIAL:			DWG. NO.		
ASI 1020			RW-13-01-05		
WEIGHT: 2029.74 grams			SCALE: 1:2.5		
			SHEET 1 OF 1		

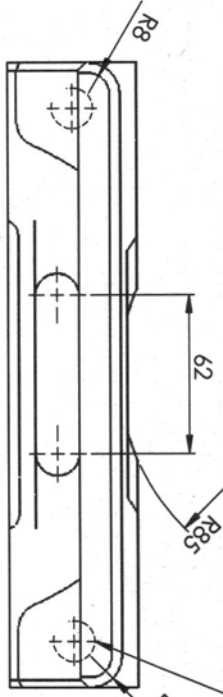

M16x2.0 Tapped Hole

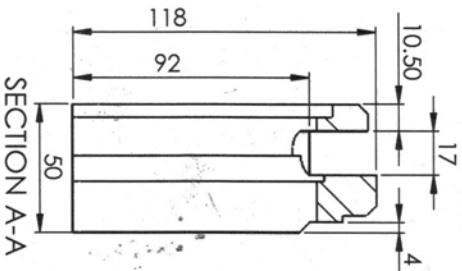
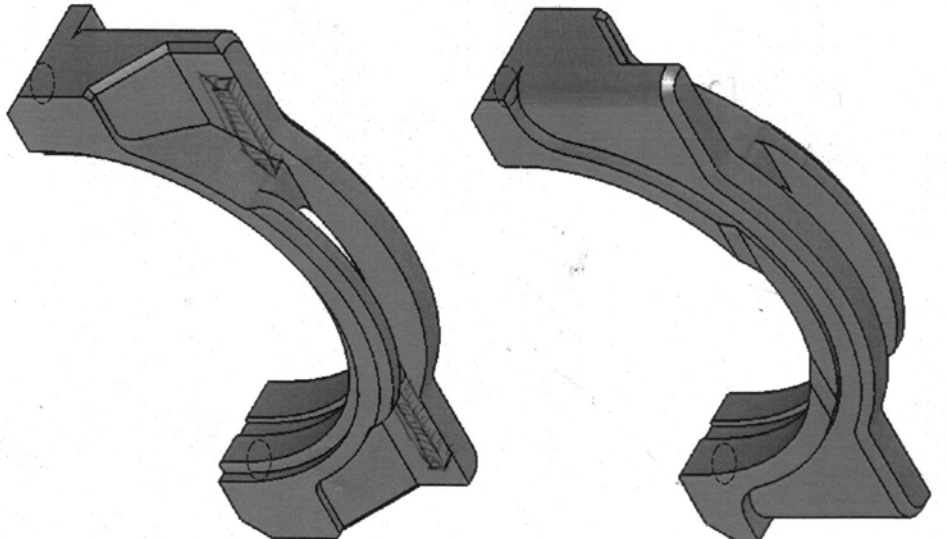
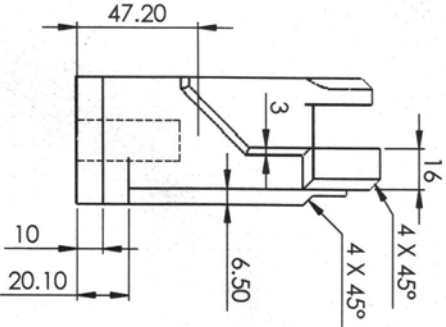
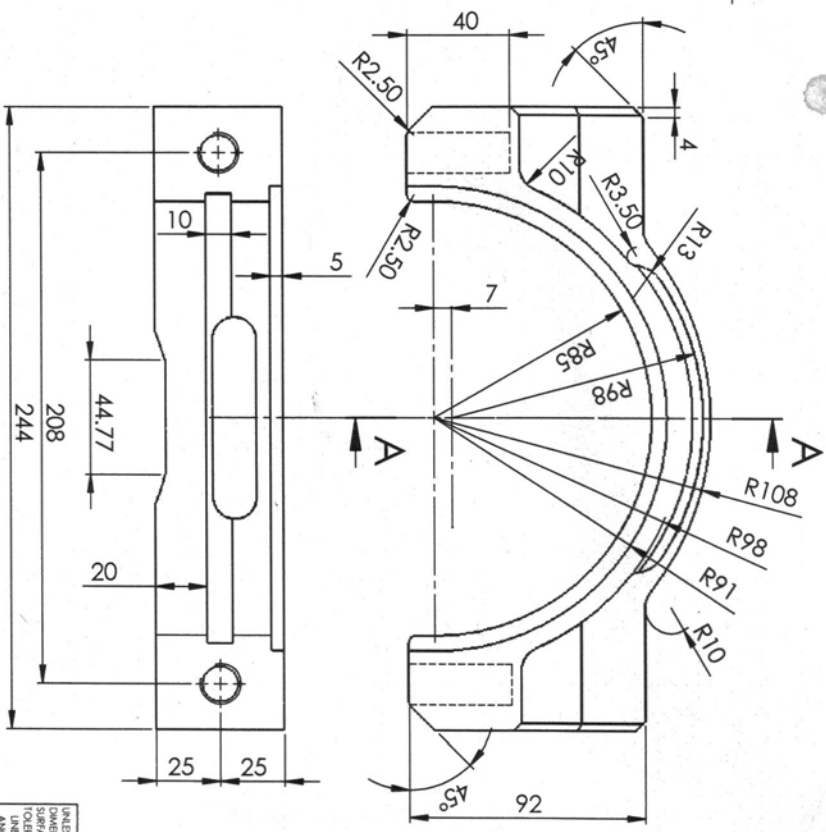

UNLESS OTHERWISE SPECIFIED:
DIMENSIONS ARE IN MILLIMETERS
TOLERANCES: RD 2769mm
LINEAR:
ANGULAR:

NAME	SIGNATURE	DATE	FINISH	DEBUR AND EDGE SHARP EDGES
DRAWN: Ewan Hemming				
CHECKED:				
APPROVED: Rene Weigkamp				
MATERIAL:				
GA				

DO NOT SCALE DRAWING

TITLE	REVISION	A
Hydrofloor		
Mid Split Ring		

WEIGHT: 2313.09 grams	DWG NO. RW-14-01-01	SHEET 1 OF 1
SCALE: 1:2		
		A3

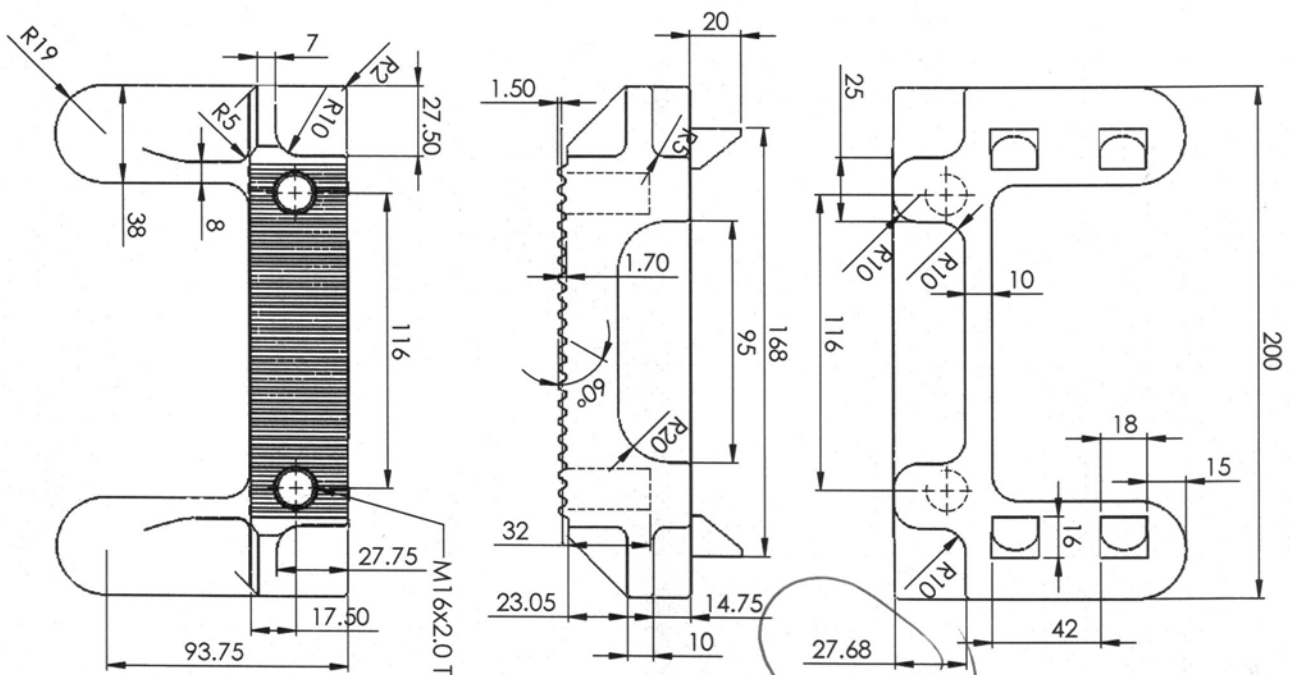

M16x2.0 Tapped Hole

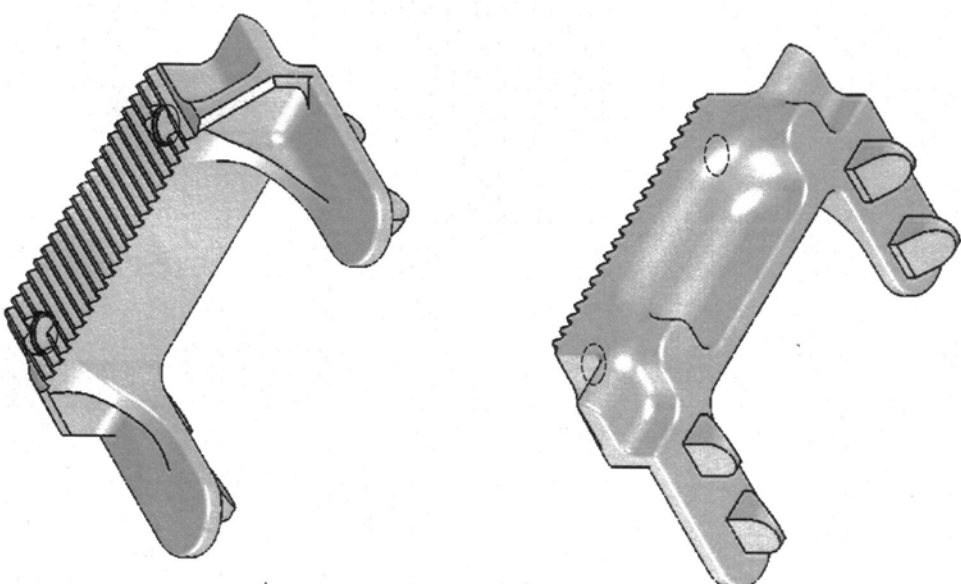

UNLESS OTHERWISE SPECIFIED:		FINISH:	DEBUR AND BREAK SHARP EDGES	DO NOT SCALE DRAWING	REVISION
DIMENSIONS ARE IN MILLIMETERS					A
TOLERANCES: ISO 2768-MK					
LINEAR:					
ANGULAR:					
NAME	SIGNATURE	DATE			
DRAWN: Emu Hommigo					
CHECKED:					
APPROVED: Rene Weglarup					
MATERIAL:					
GA:					

Wing Block

RW-14-06-01

WEIGHT: 1218.47 grams

SCALE: 1:2

SHEET 1 OF 1

A3

REV.	DETAIL OF CHANGE	DCP NO.	DATE	MATERIAL & SIZE	STEEL FORGING	ASSOCIATED DOCUMENTS	ISO 4012	DRAWING NO.
1.0	ISSUED FOR COMMENT		18/10/05	GRADE		RW-15-00-00-R1.pdf	003 409 412	
				FINISHING PROCESS		SURFACES TO BE SCRATCH FREE	003 295 0018	OUTER CLAMP SADDLE
				USED ON / FOR:	ASSEMBLY DRG.	U.O.S. TOLERANCE TO 150 2788 -mk	150 STANDARDS	DRAWING NO.
				APPR.	DATE	DATE 1st ISSUE	REVISION	RW-15-00-00
							1.0	SCALE 1:2
								SHEET NO. 1 OF 1

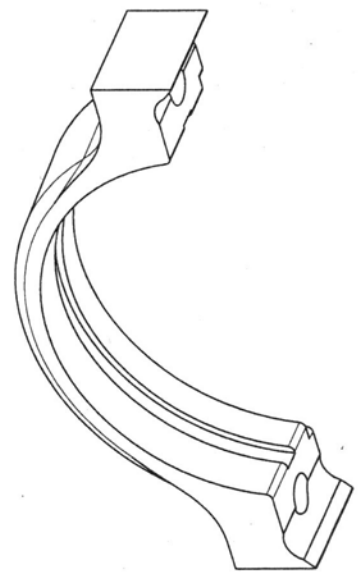
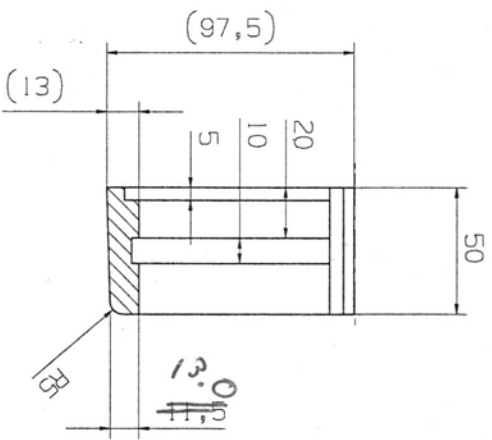
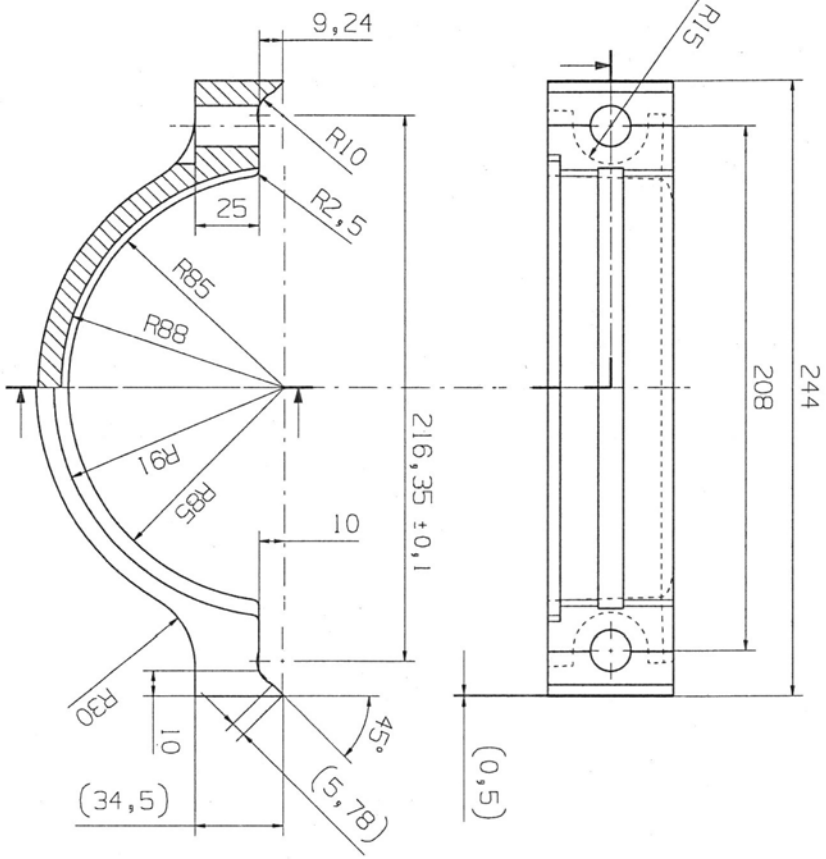

MASS = 1,67 kg