

REVISION HISTORY			
REV	DESCRIPTION	DATE	APPROVED

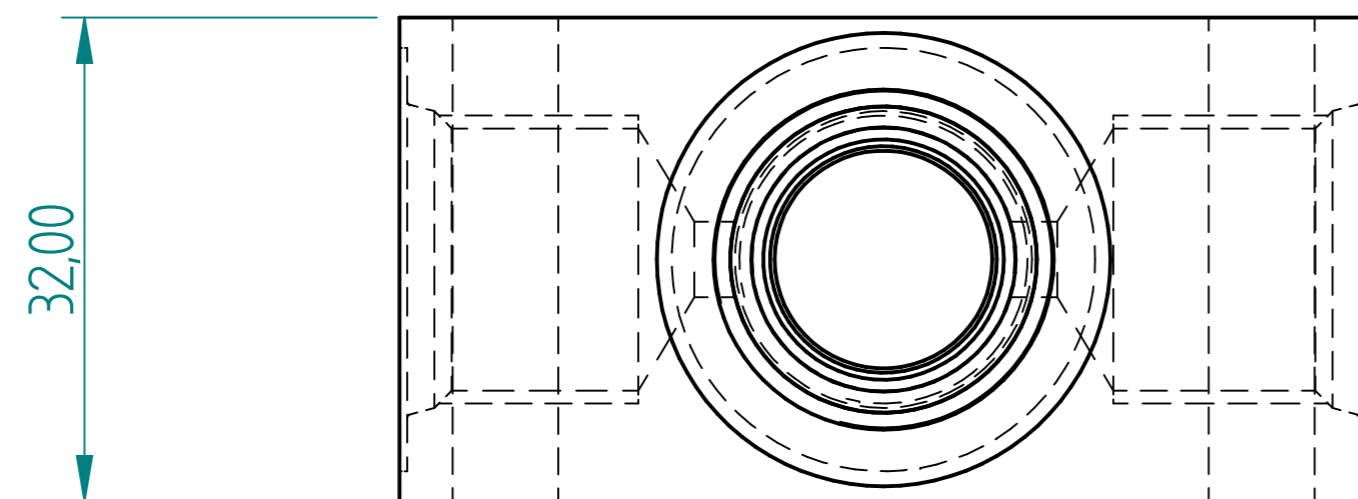

DRAWN	NAME	DATE	PREMAC		
APPROVED	Dan	05/11/18			
MATERIAL					
TREATMENT					
UNLESS OTHERWISE SPECIFIED DIMENSIONS ARE IN MILLIMETERS			SIZE	DWG NO	REV
1 ST ANGLE ANGLES ±0.1°			A4		
2 PL ±0.02 3 PL ±0.005			FILE NAME: C10-3 Block.dft		
SCALE:			WEIGHT:	SHEET 1 OF 2	

REVISION HISTORY			
REV	DESCRIPTION	DATE	APPROVED

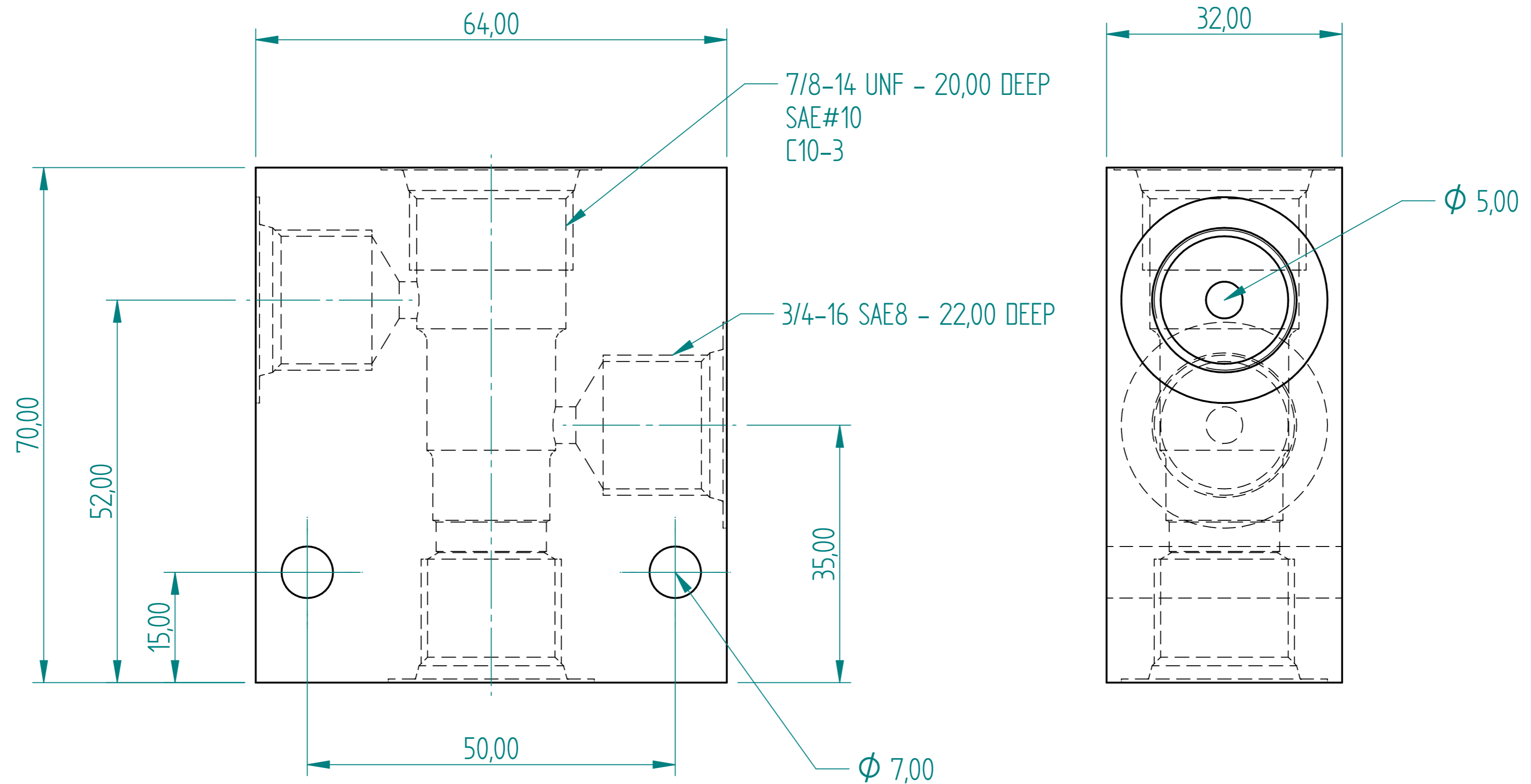
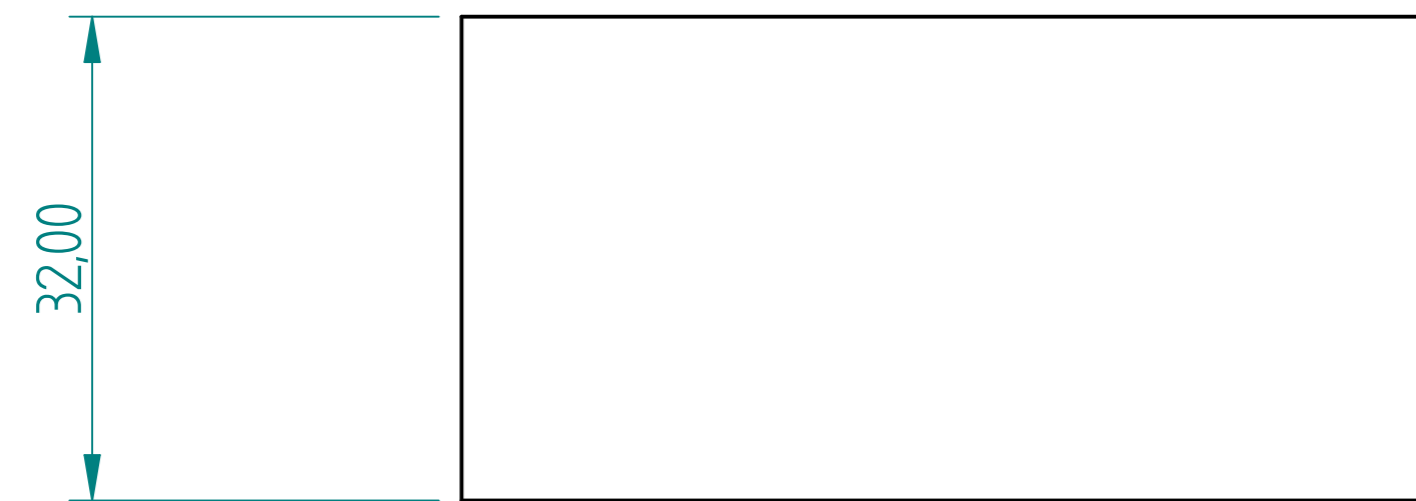
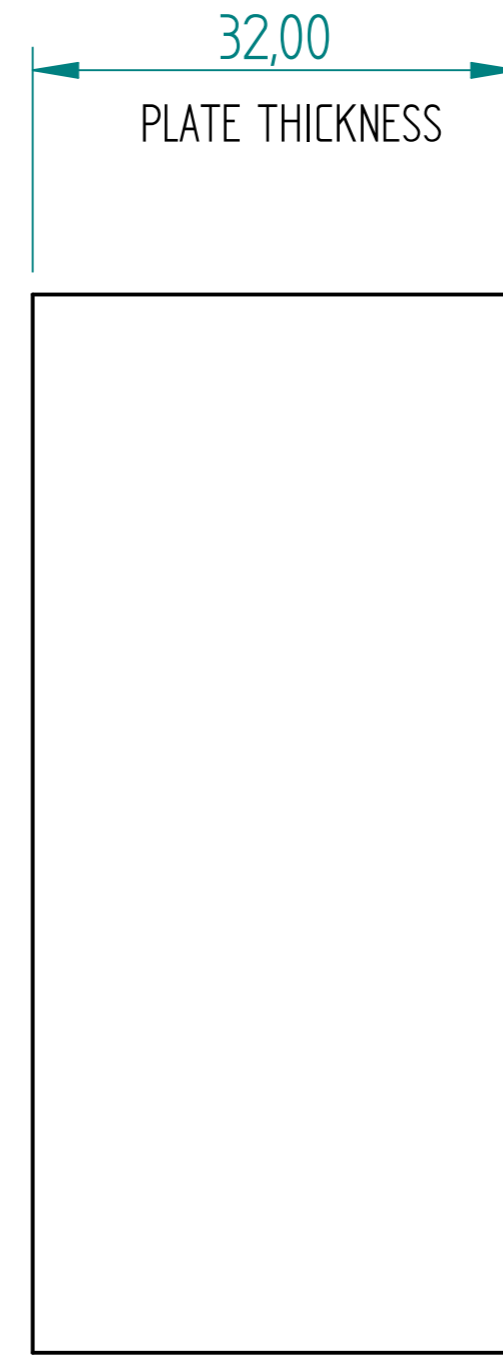
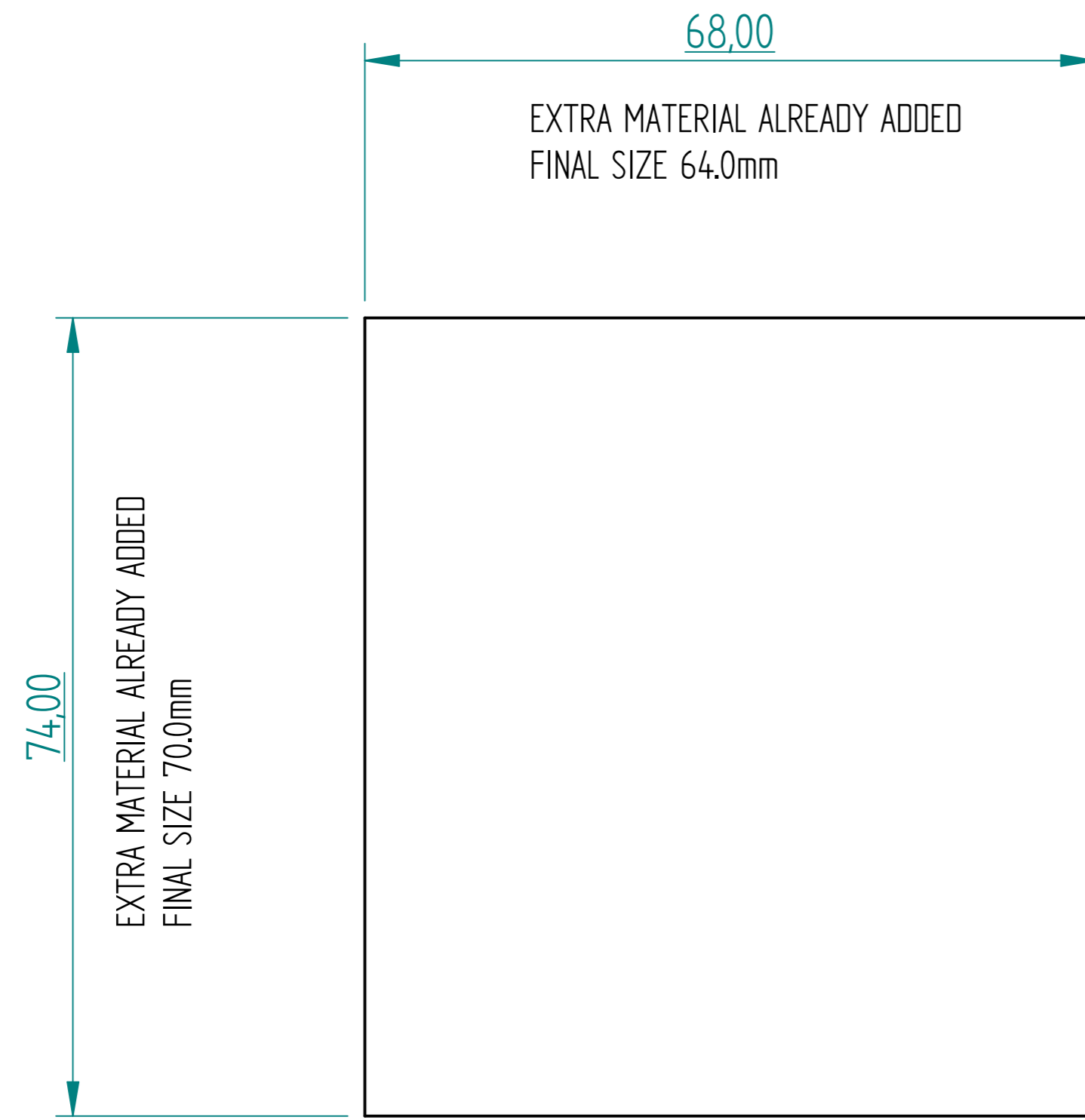

MATERIAL CUT SIZES

	NAME	DATE	PREMAC	
DRAWN	Dan	05/11/18		
APPROVED				
MATERIAL				
TREATMENT			TITLE	
UNLESS OTHERWISE SPECIFIED DIMENSIONS ARE IN MILLIMETERS			SIZE A4	DWG NO
1st ANGLE ANGLES ±0.1°			FILE NAME: C10-3 Block.dft	REV
2 PL ±0.02 3 PL ±0.005			SCALE:	WEIGHT: SHEET 2 OF 2