

REVISION HISTORY			
REV	DESCRIPTION	DATE	APPROVED

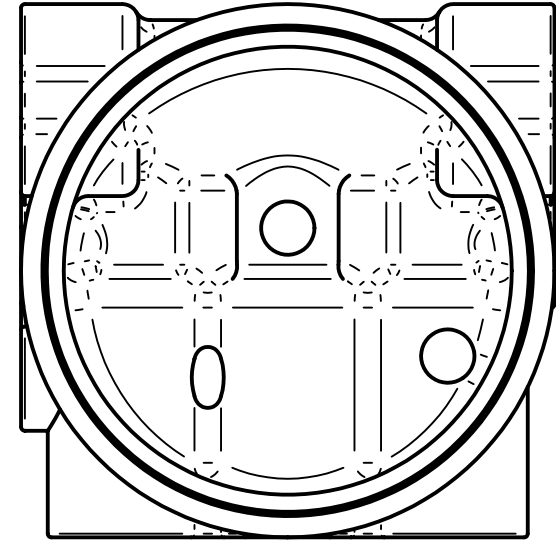
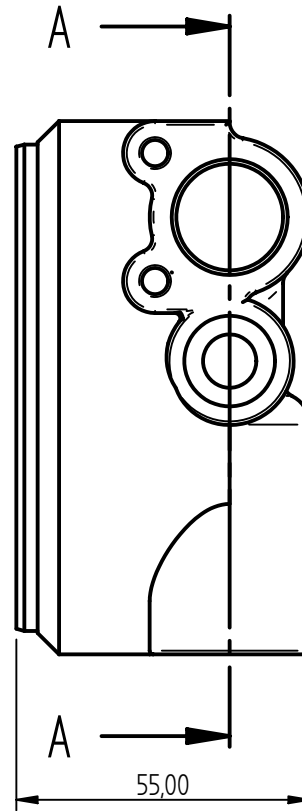
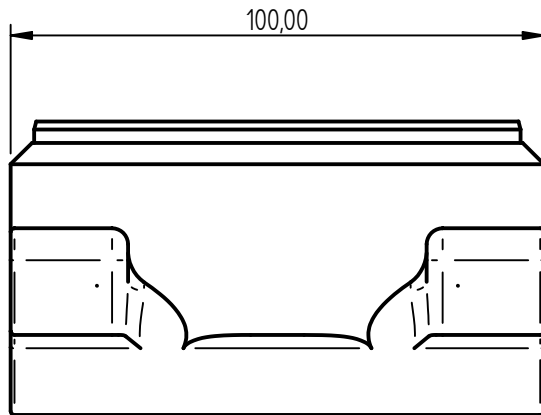
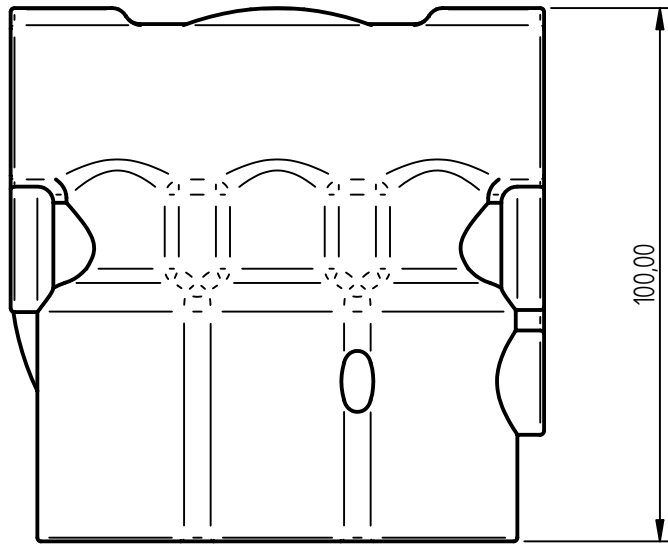

WEIGHT 1.5 KG

OUT RIGGER BLOCK

for evaluation only

DRAWN	NAME	DATE	PREMAC	
APPROVED	Don	06/13/05	PRECISION MACHINE MANUFACTURERS (PTY)LTD.	
MATERIAL			TITLE	
TREATMENT			FILE NAME: Out Rigger Block Investment Cast.dft	
UNLESS OTHERWISE SPECIFIED DIMENSIONS ARE IN MILLIMETERS ANGLES ±0.1°			SIZE	REV
2 PL ±0.02 3 PL ±0.005			A2	
SCALE:			WEIGHT:	SHEET 1 OF 2

REVISION HISTORY			
REV	DESCRIPTION	DATE	APPROVED

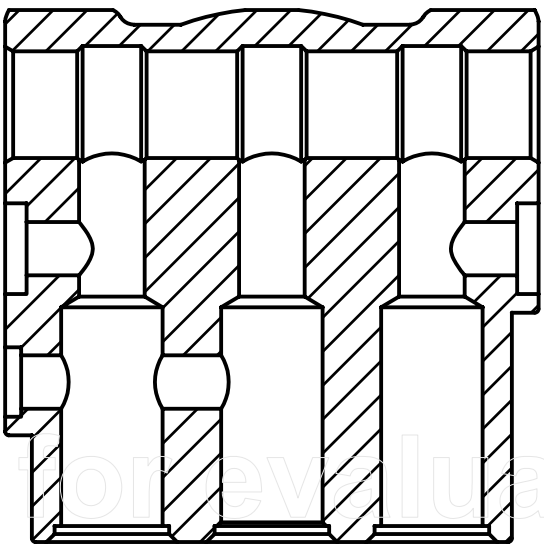
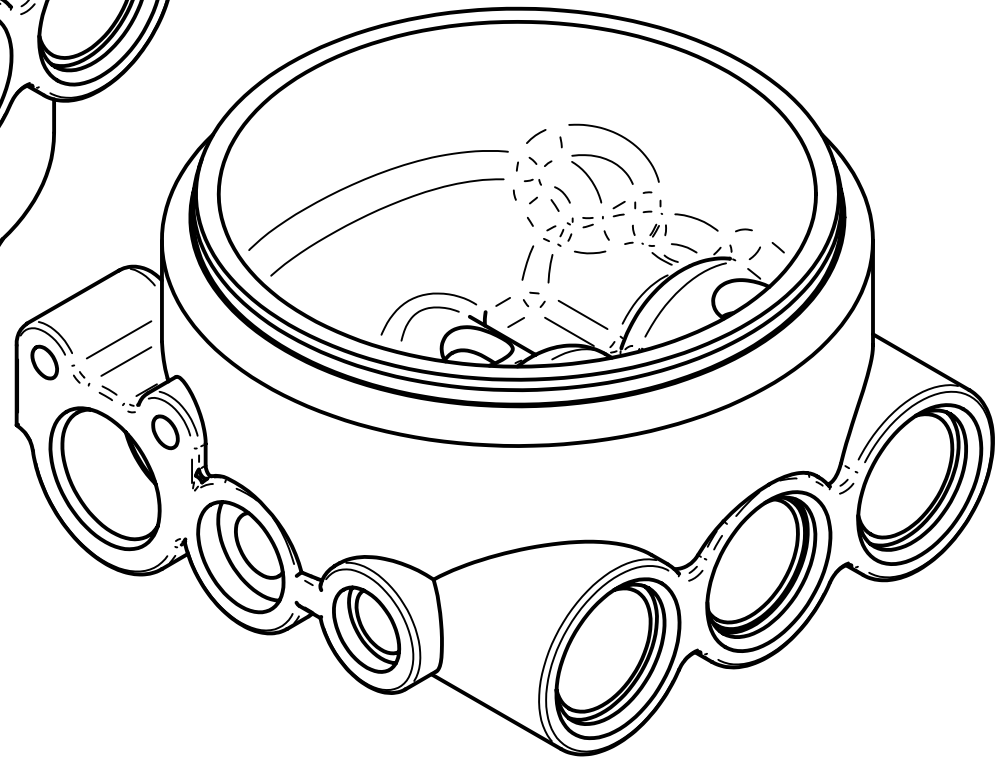
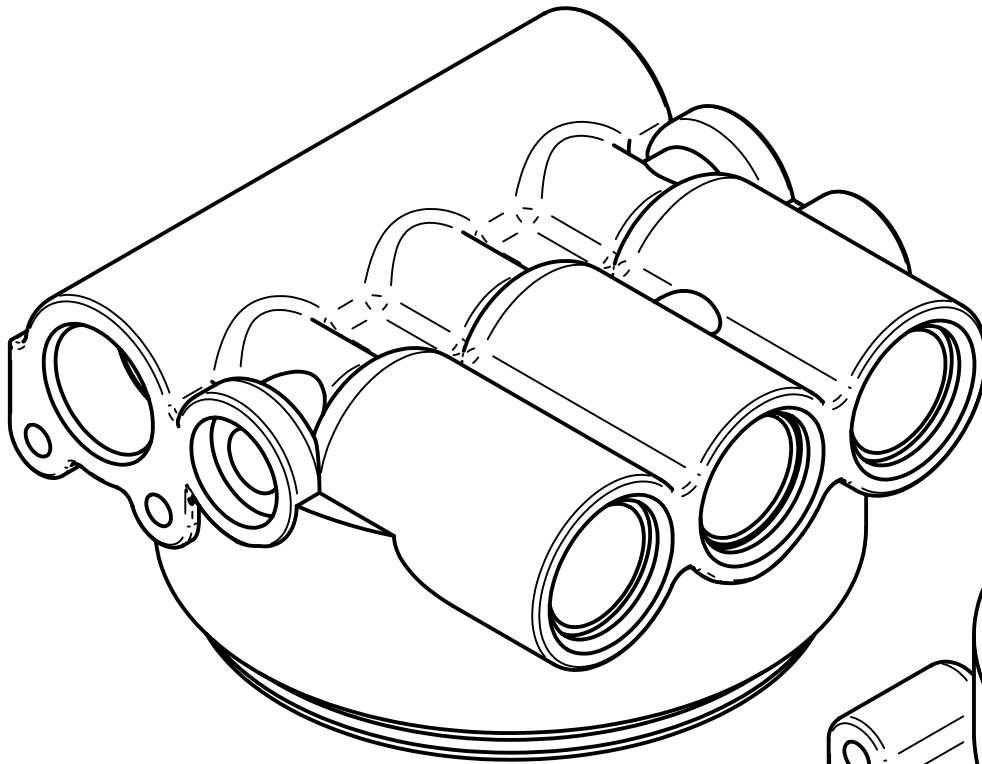

SECTION A-A

DRAWN	NAME	DATE	PREMAC	
APPROVED	Don	06/13/05	PRECISION MACHINE MANUFACTURERS (PTY)LTD.	
MATERIAL	TITLE		FILE NAME: Out Rigger Block Investment Cast.dft	
TREATMENT	SIZE DWG NO		REV	
UNLESS OTHERWISE SPECIFIED DIMENSIONS ARE IN MILLIMETERS ANGLES ±0.1°			AZ	
2 PL ±0.02 3 PL ±0.005			SCALE:	WEIGHT: SHEET 2 OF 2