

REVISION HISTORY			
REV	DESCRIPTION	DATE	APPROVED

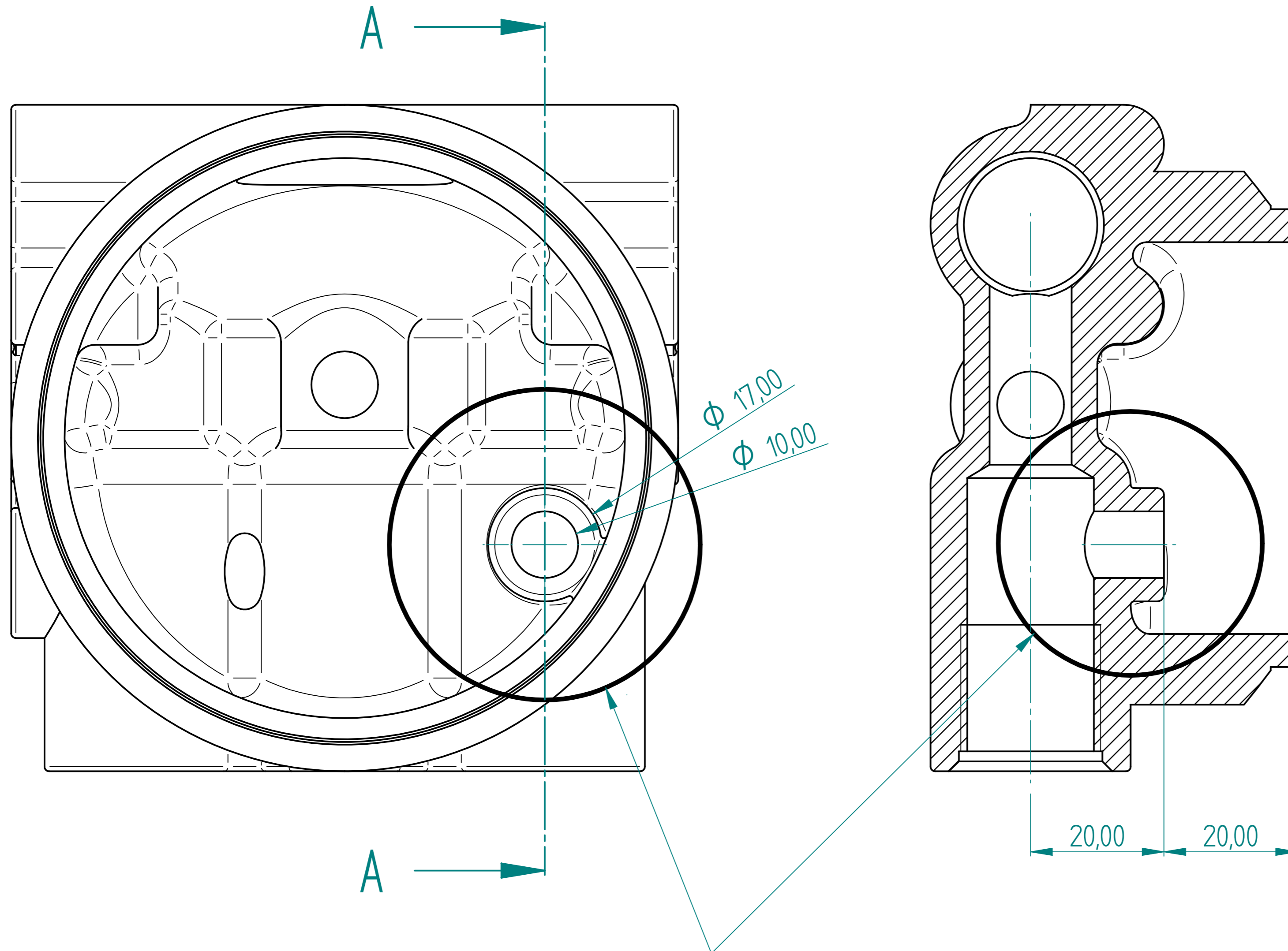

SECTION A-A

A BOSS OF DIA 17.mm AND MAINTAINING THE THROUGH HOLE OF DIA 10.mm NEEDS TO BE ADDED TO THE BLOCK AT THE POSITION INDICATED ON THE WAX MOULD DIE PLATE.

	NAME	DATE	<b>PREMAC</b>			
DRAWN	Dan	07/27/10				
APPROVED			TITLE			
MATERIAL						
TREATMENT			UNLESS OTHERWISE SPECIFIED DIMENSIONS ARE IN MILLIMETERS			
			1 <sup>st</sup> ANGLE	SIZE A4	DWG NO	REV
			2 PL ±0.02 3 PL ±0.005	FILE NAME: Out Rigger Block Mod.dft		
				SCALE:	WEIGHT:	SHEET 1 OF 2

REVISION HISTORY			
REV	DESCRIPTION	DATE	APPROVED

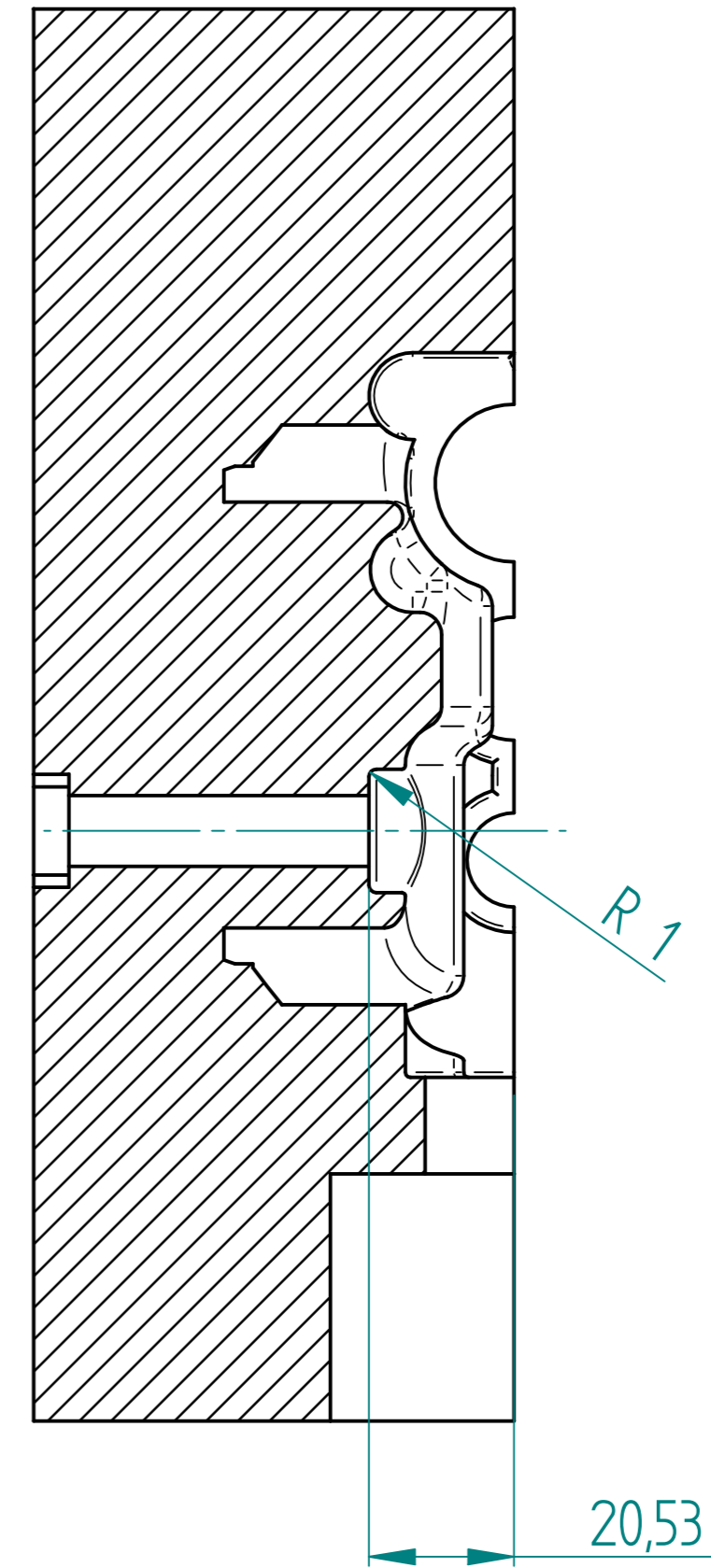
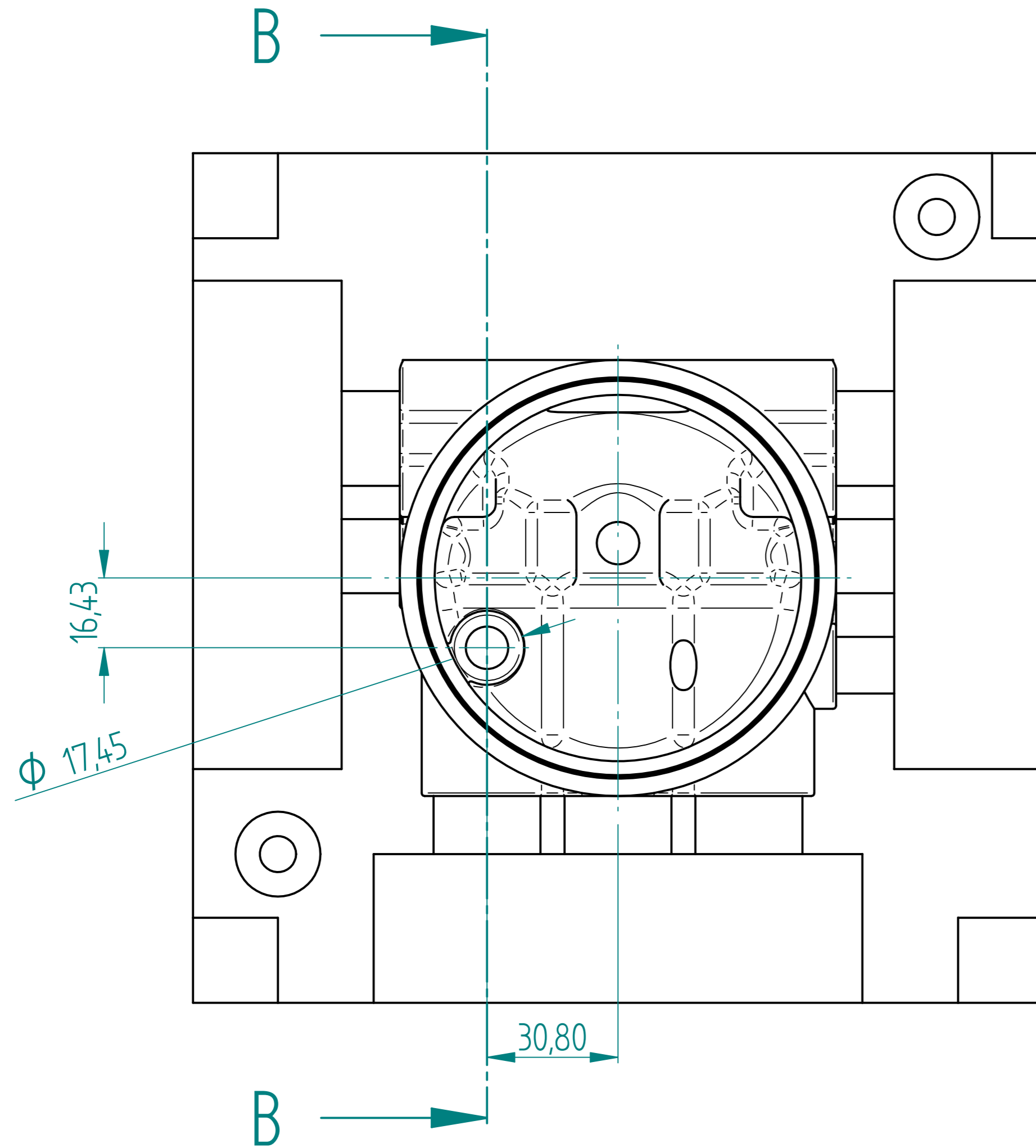

## SECTION B-B

	NAME	DATE	<b>PREMAC</b>	
DRAWN	Dan	07/27/10		
APPROVED				
MATERIAL				
TREATMENT			TITLE	
UNLESS OTHERWISE SPECIFIED DIMENSIONS ARE IN MILLIMETERS			SIZE A4	DWG NO
1 <sup>st</sup> ANGLE ANGLES $\pm 0,1^\circ$			FILE NAME: Out Rigger Block Mod.dft	
2 PL $\pm 0,02$ 3 PL $\pm 0,005$			SCALE:	WEIGHT:
			SHEET 2 OF 2	