

REVISION HISTORY			
REV	DESCRIPTION	DATE	APPROVED

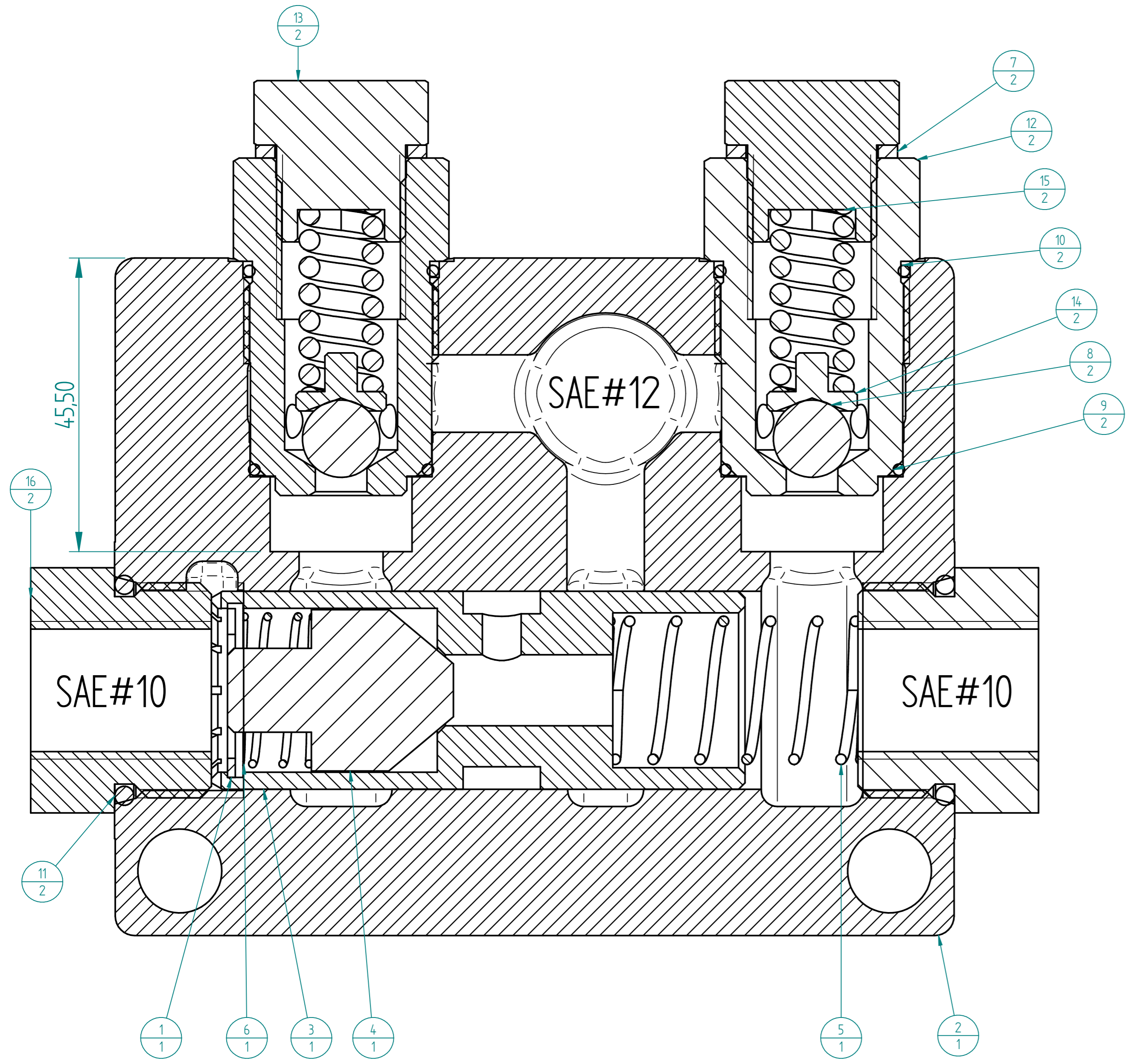

Item Number	Title	Document Number	Quantity
1	Internal Circlip	CCI27	1
2	Cable Reel Valve	CRV-01	1
3	Piston	CRV-02	1
4	Check Poppet	CRV-03	1
5	Piston Spring	CRV-04	1
6	Check Spring	CRV-05	1
7	Copper Washer	D20-2.5-2	2
8	Steel Ball	Dia 12	2
9	O-Ring	P2-022	2
10	O-Ring	P2-023	2
11	O-Ring	P3-916	2
12	Ball Relief Housing	PRB-01	2
13	Cap	PRB-02	2
14	Ball Pusher	PRB-03	2
15	Spring	PRB-04	2
16	SAE 16 Reducer	SAE 16 - 1/2	2

	NAME	DATE	PREMAC	
DRAWN	Dan	09/04/23	PRECISION MACHINE MANUFACTURERS (PTY)LTD.	
APPROVED			TITLE	
MATERIAL			Cable Reel Valve	
TREATMENT			SIZE	DWG NO
UNLESS OTHERWISE SPECIFIED DIMENSIONS ARE IN MILLIMETERS ANGLES ±0.1° 1st ANGLE			A2	CRV
			SCALE:	WEIGHT:
2 PL ±0.02 3 PL ±0.005			FILE NAME: Cable Reel Valve.dft	SHEET 13 OF 14