

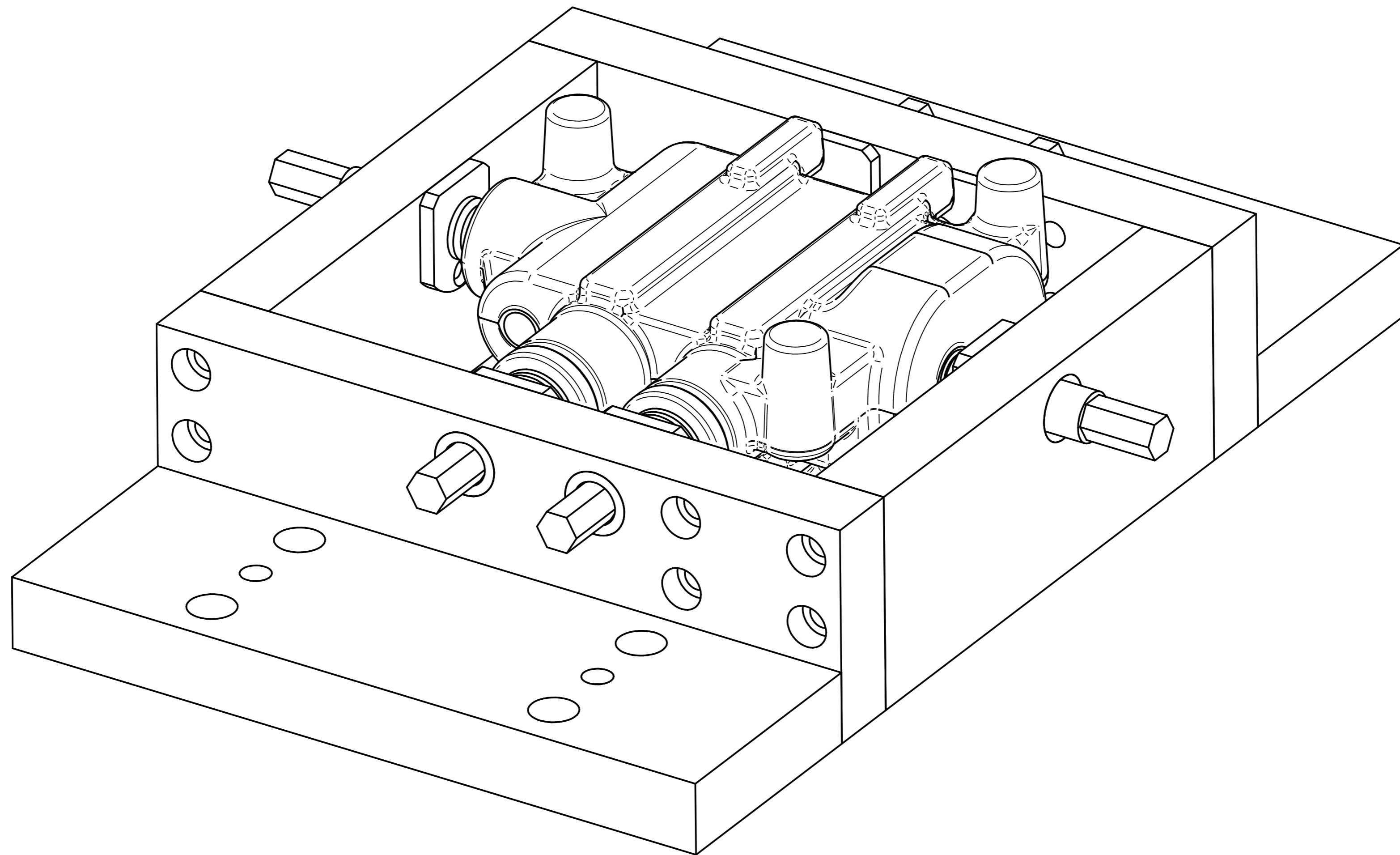

REVISION HISTORY			
REV	DESCRIPTION	DATE	APPROVED



	NAME	DATE	PREMAC		
DRAWN	Dan	08/08/22			
APPROVED					
MATERIAL					
TREATMENT			TITLE		
UNLESS OTHERWISE SPECIFIED DIMENSIONS ARE IN MILLIMETERS ANGLES ±0.1°			SIZE A4	DWG NO	REV
1 ST ANGLE  2 PL ±0.02 3 PL ±0.005			FILE NAME: Machining_Jig.dft	SCALE:	WEIGHT:
					SHEET 1 OF 7

REVISION HISTORY			
REV	DESCRIPTION	DATE	APPROVED

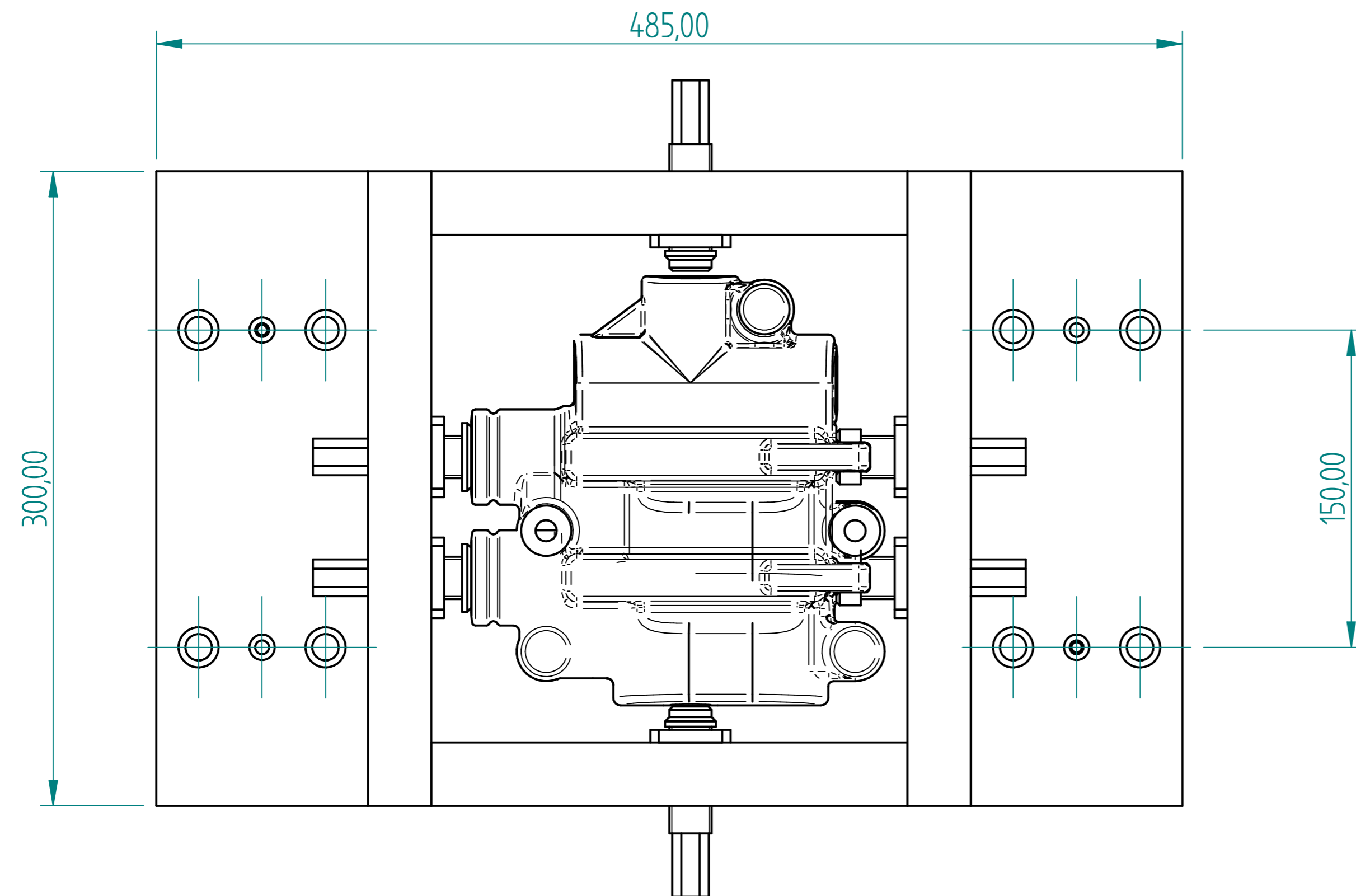
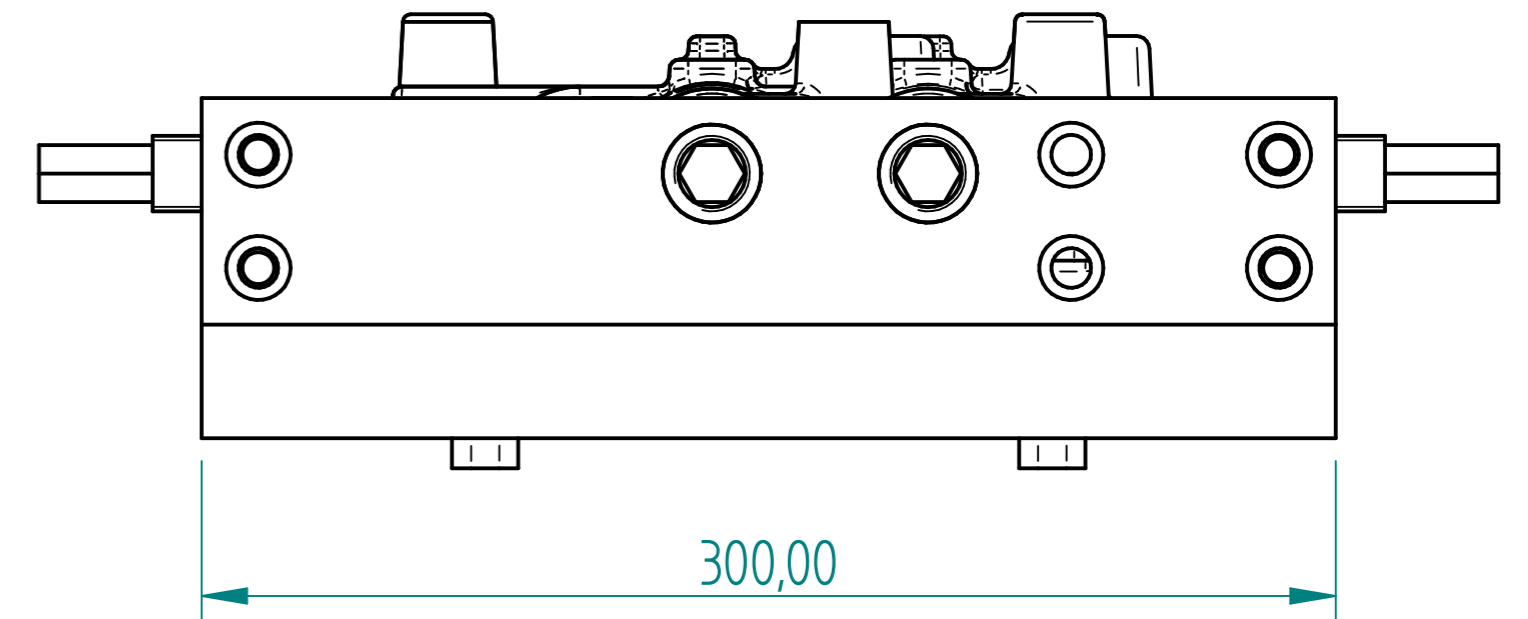
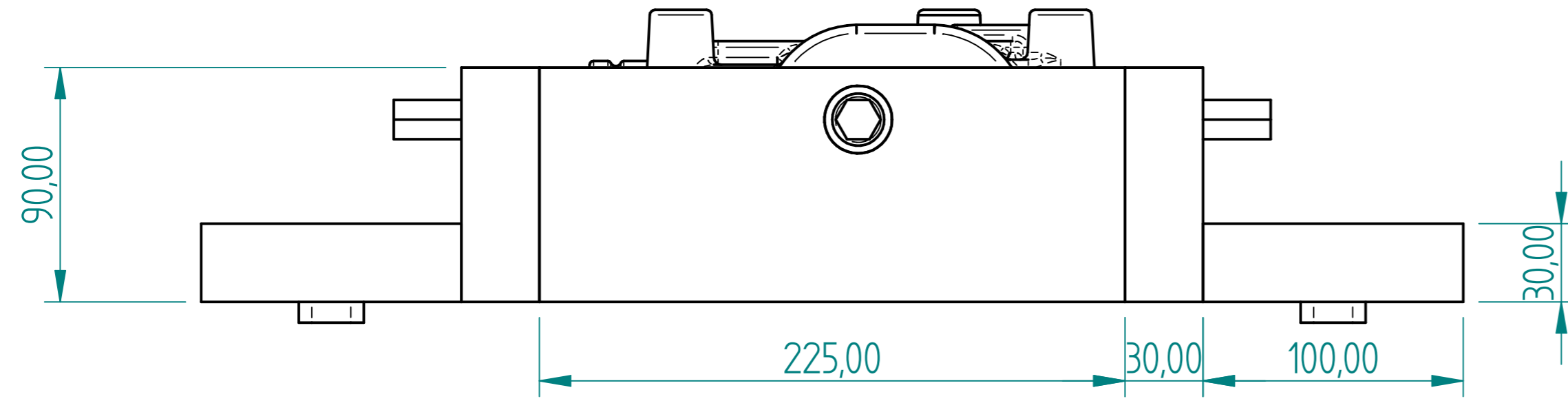

DRAWN	NAME	DATE	PREMAC	
APPROVED	Dan	08/08/22		
MATERIAL			TITLE	
TREATMENT			FILE NAME: Machining_Jig.dft	
UNLESS OTHERWISE SPECIFIED DIMENSIONS ARE IN MILLIMETERS ANGLES ±0.1°			SIZE A4	DWG NO
1st ANGLE 2 PL ±0.02 3 PL ±0.005			SCALE:	WEIGHT:
			SHEET 2 OF 7	

REVISION HISTORY			
REV	DESCRIPTION	DATE	APPROVED

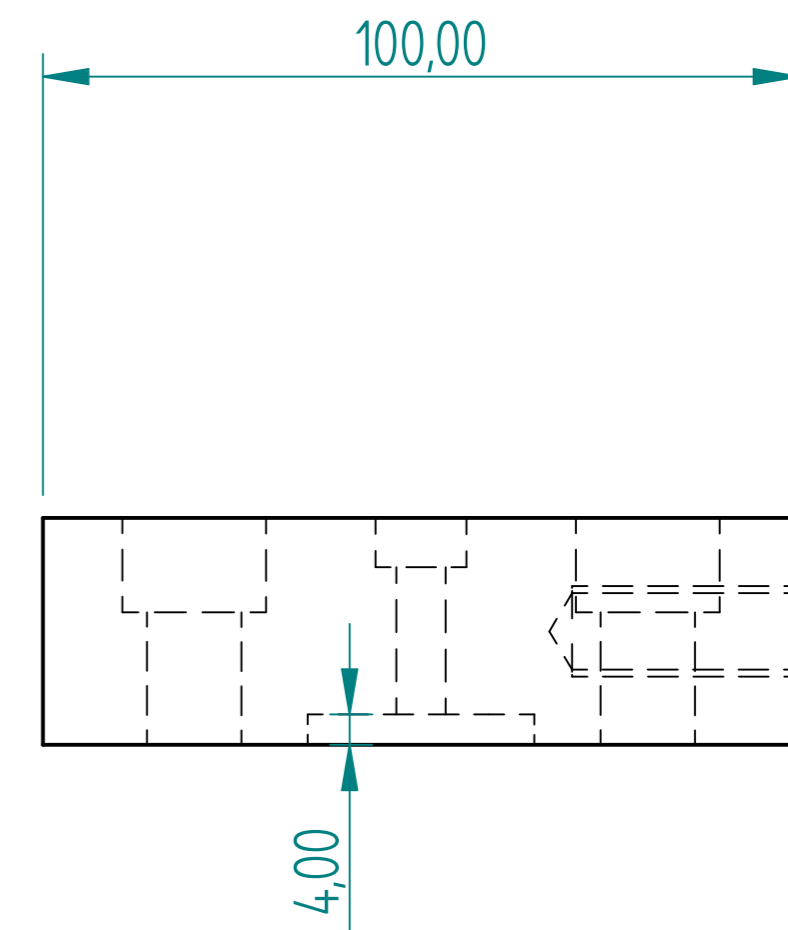
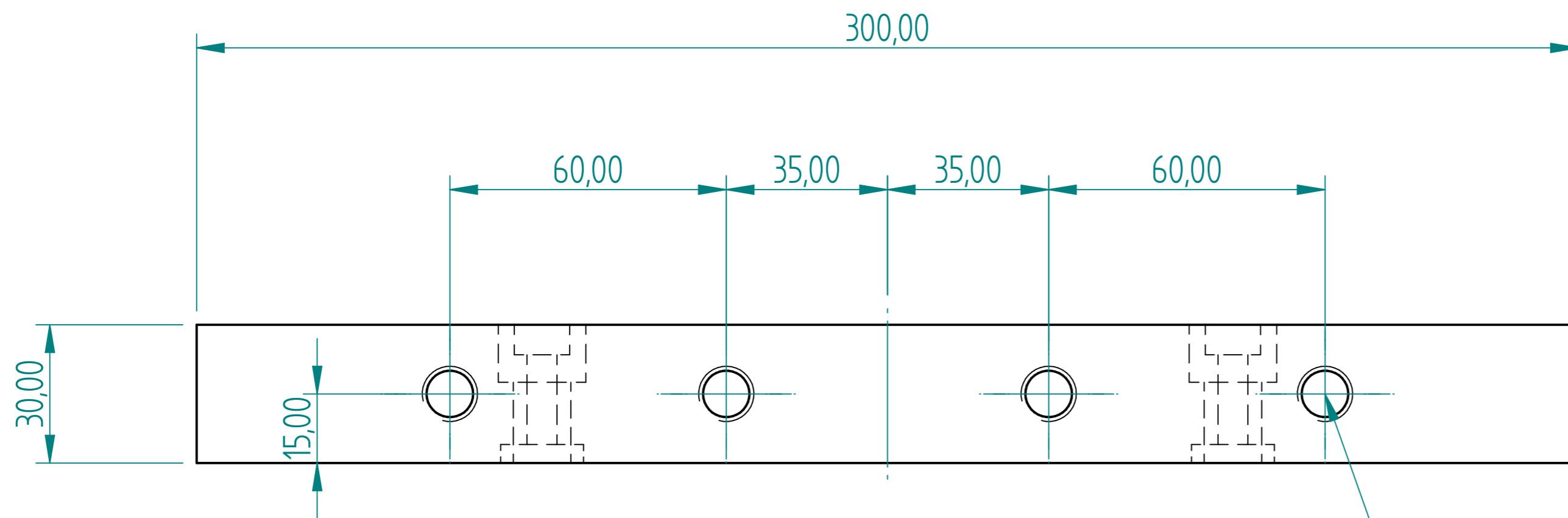

M12 - 30,00 DEEP

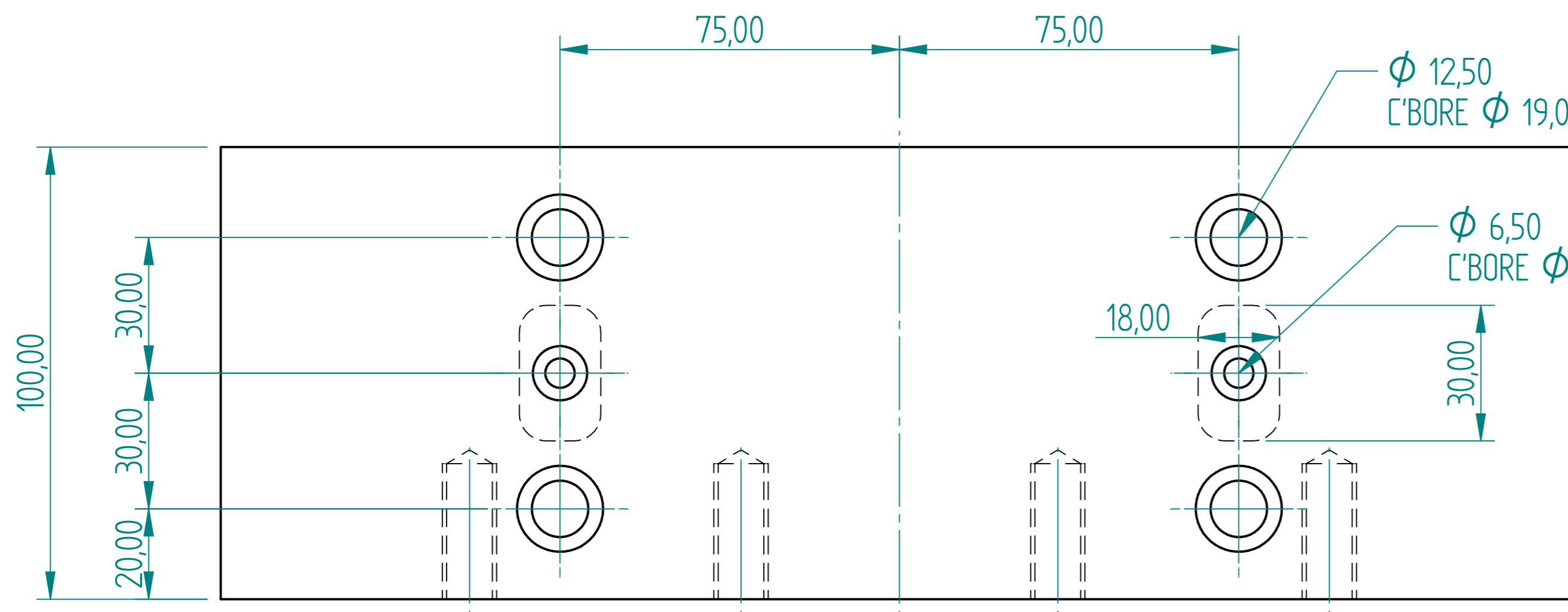

2 of

	NAME	DATE	PREMAC	
DRAWN	Dan	08/08/22		
APPROVED			TITLE	
MATERIAL				
TREATMENT				
UNLESS OTHERWISE SPECIFIED DIMENSIONS ARE IN MILLIMETERS			SIZE A4	DWG NO
1st ANGLE ANGLES $\pm 0.1^\circ$			REV	
2 PL ± 0.02 3 PL ± 0.005			FILE NAME: Machining_Jig.dft	
SCALE:		WEIGHT:	SHEET 3 OF 7	

REVISION HISTORY			
REV	DESCRIPTION	DATE	APPROVED

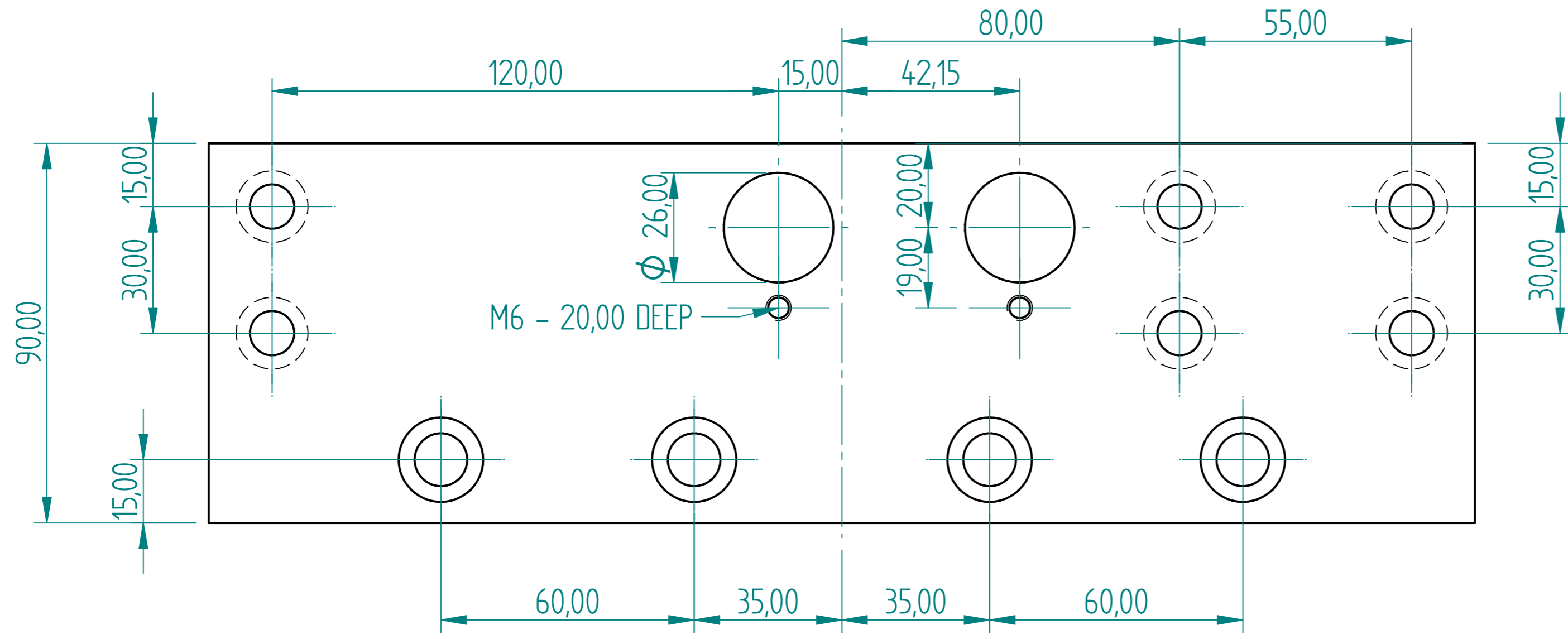
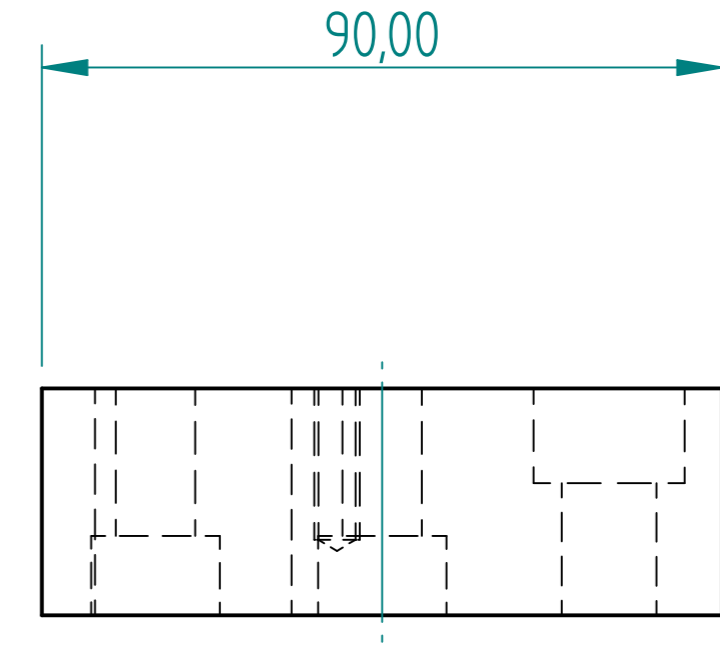
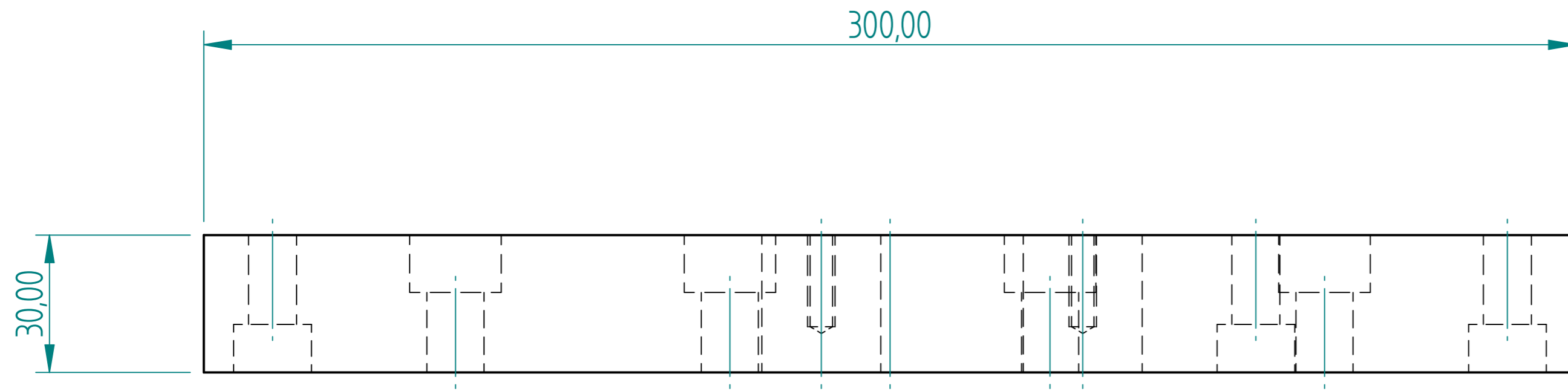

1 of each

	NAME	DATE	PREMAC	
DRAWN	Dan	08/08/22		
APPROVED			TITLE	
MATERIAL				
TREATMENT				
UNLESS OTHERWISE SPECIFIED DIMENSIONS ARE IN MILLIMETERS ANGLES $\pm 0.1^\circ$			SIZE A4	DWG NO
1st ANGLE 			FILE NAME: Machining_Jig.dft	
2 PL ± 0.02 3 PL ± 0.005			SCALE:	WEIGHT: SHEET 4 OF 7

REVISION HISTORY			
REV	DESCRIPTION	DATE	APPROVED

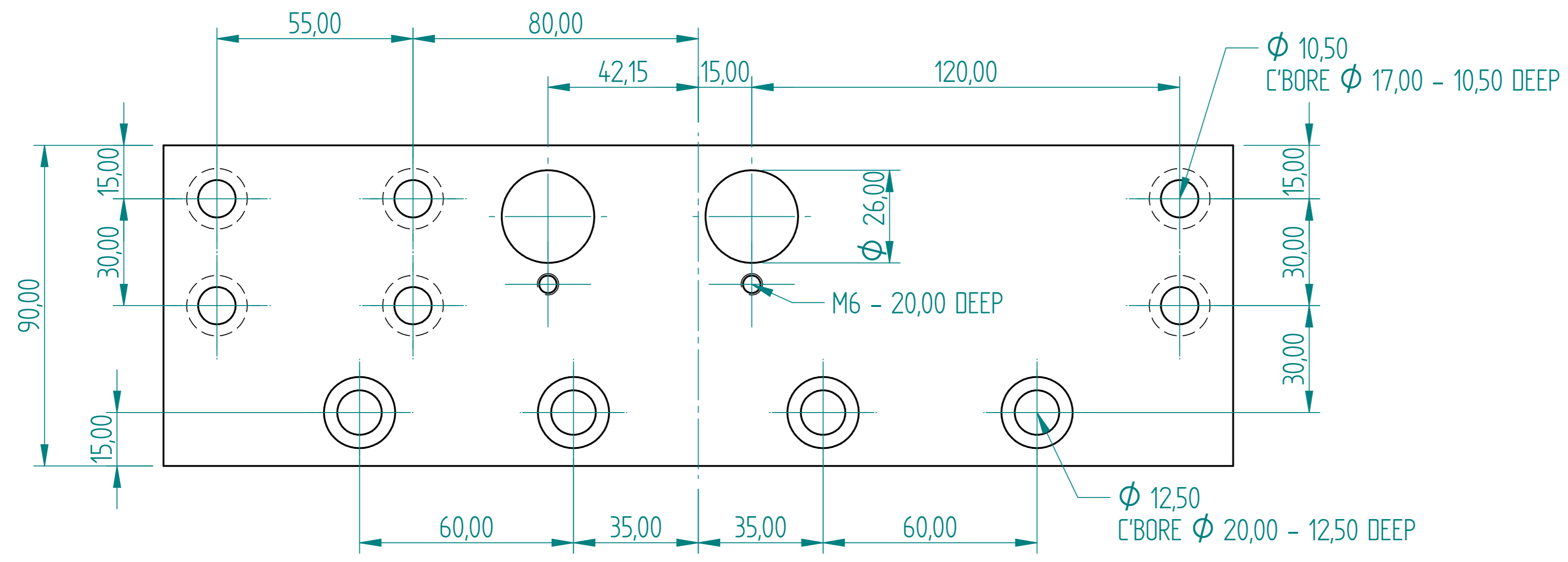
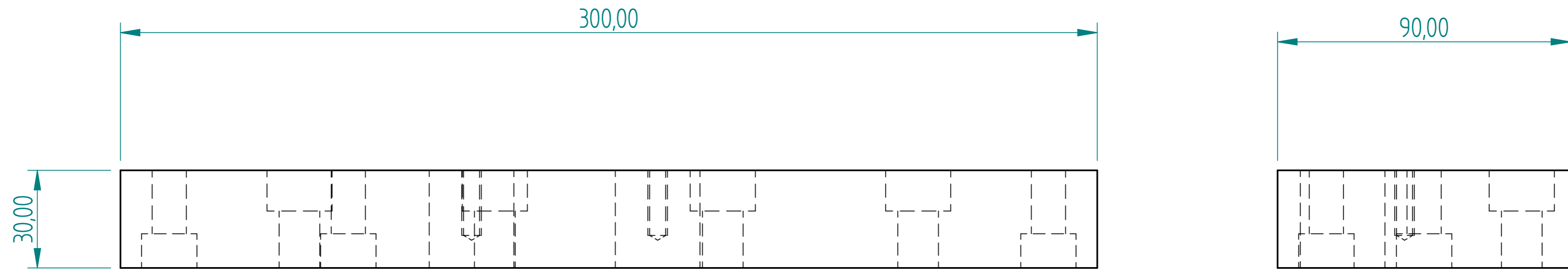

1 of each

	NAME	DATE	PREMAC	
DRAWN	Dan	08/08/22		
APPROVED			TITLE	
MATERIAL			SIZE	DWG NO
TREATMENT			A4	
UNLESS OTHERWISE SPECIFIED DIMENSIONS ARE IN MILLIMETERS			FILE NAME: Machining_Jig.dft	REV
1st ANGLE 2 PL ±0.02 3 PL ±0.005			SCALE:	WEIGHT:
			SHEET 5 OF 7	

REVISION HISTORY			
REV	DESCRIPTION	DATE	APPROVED

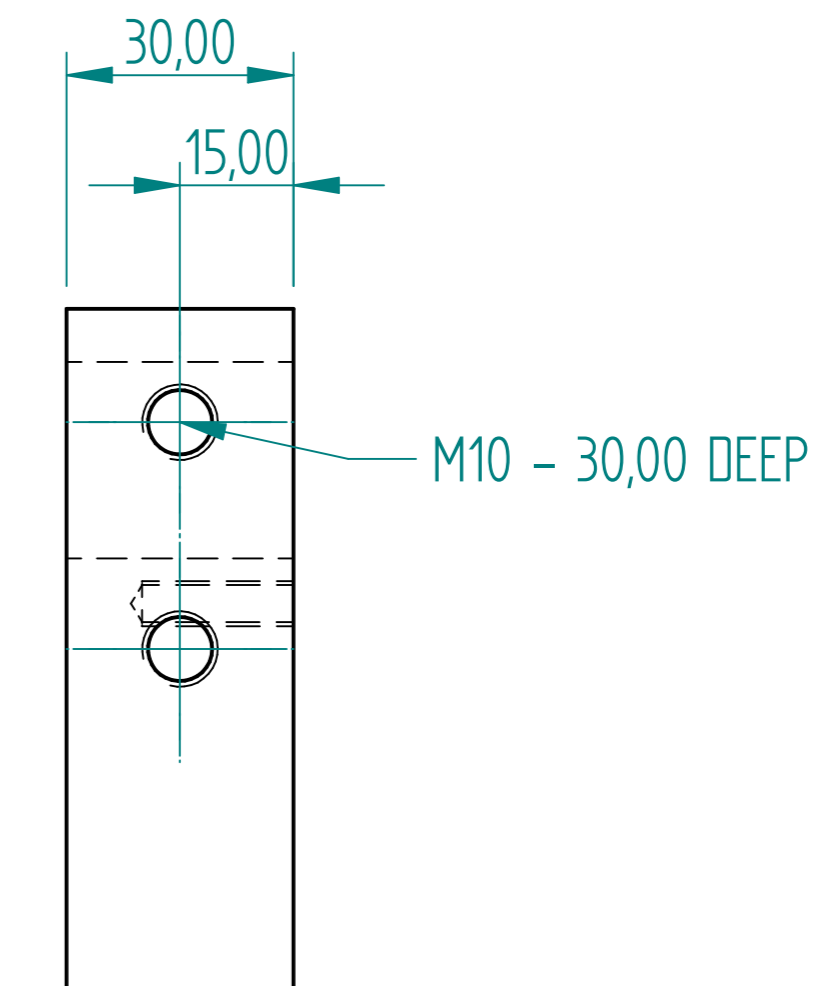
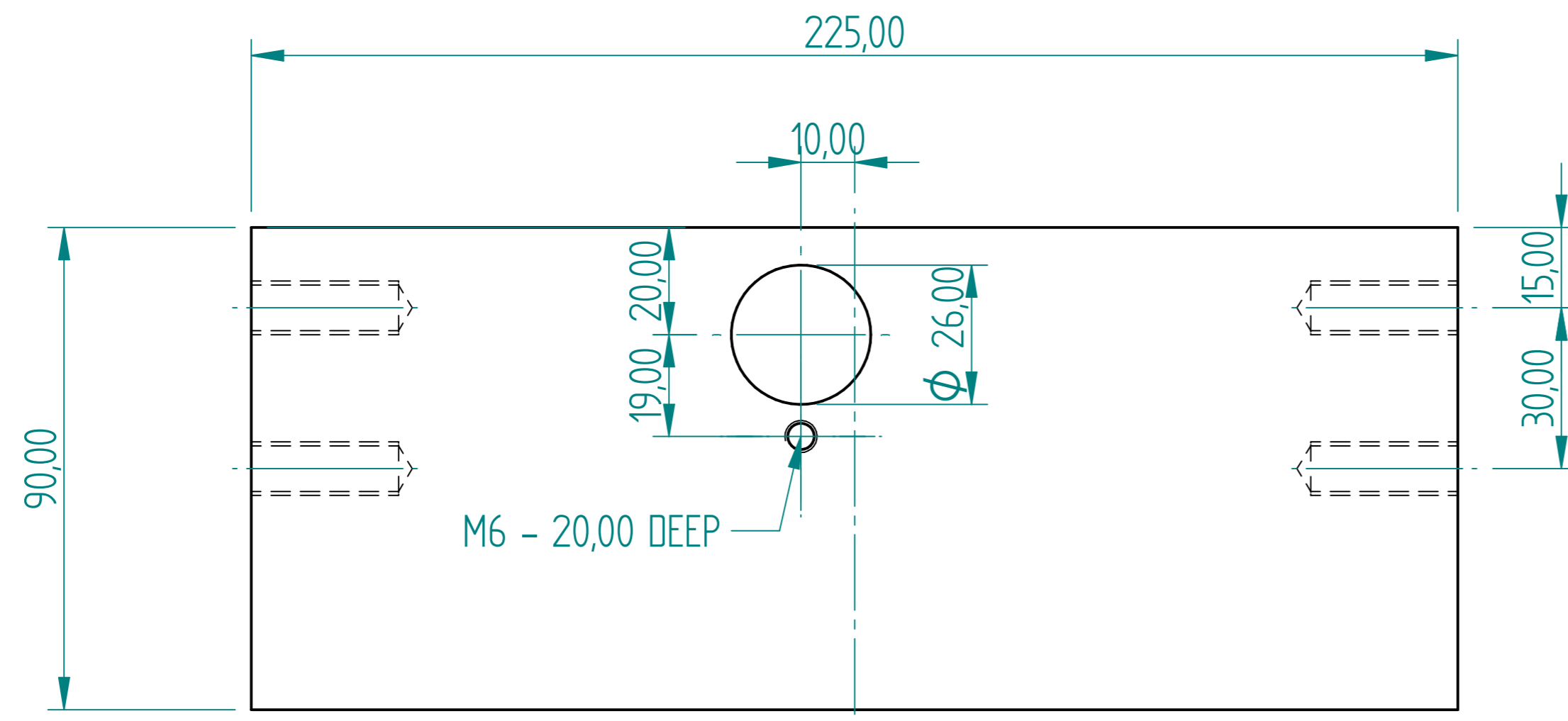
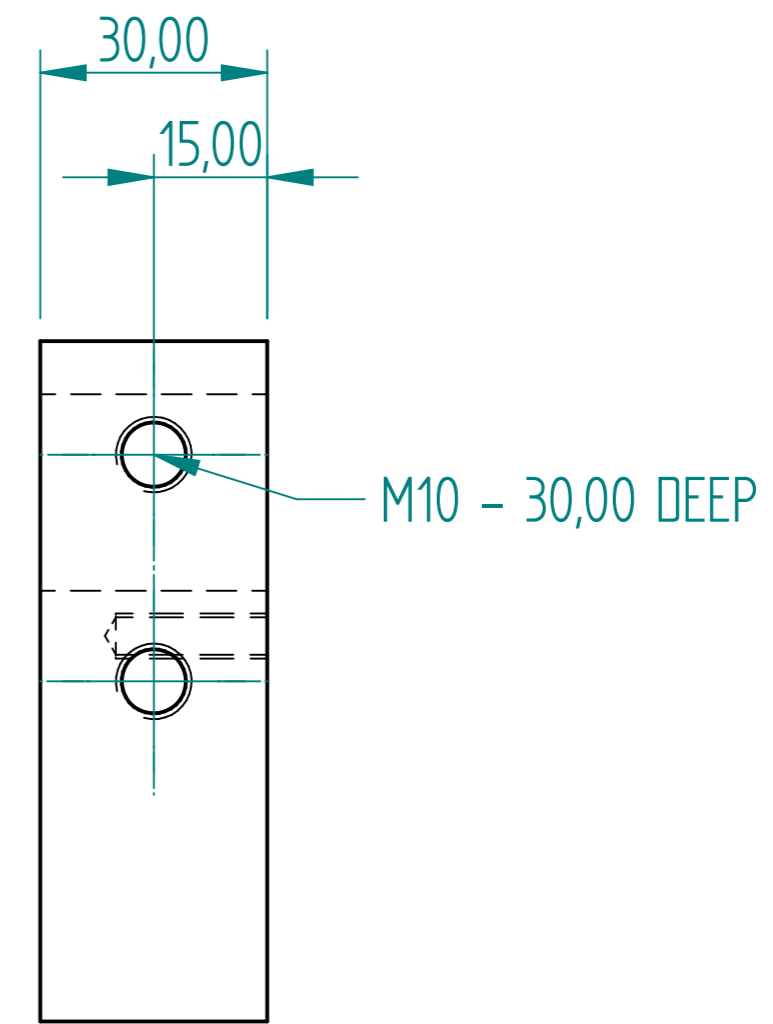
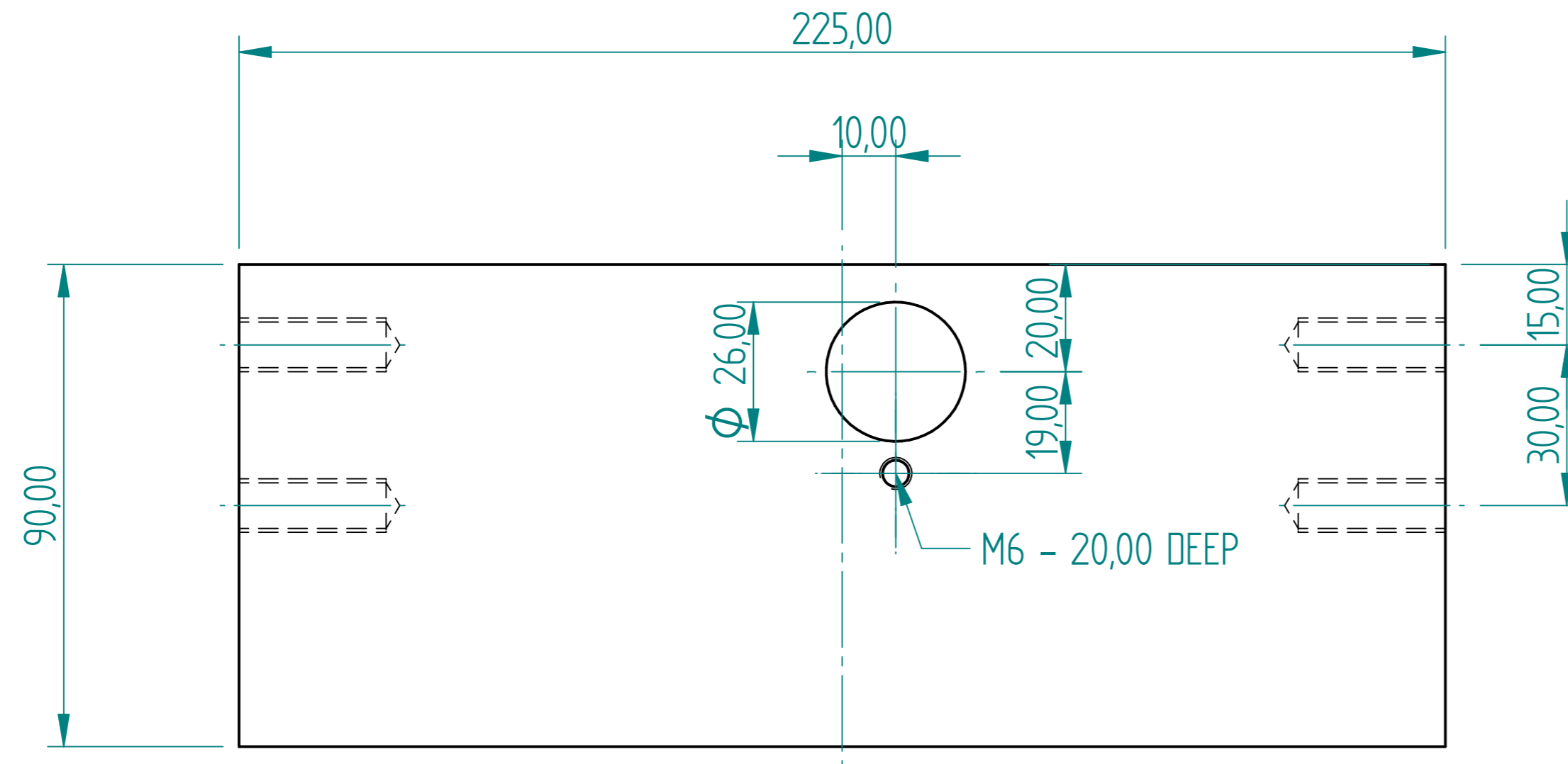

1 of each

	NAME	DATE	PREMAC	
DRAWN	Dan	08/08/22		
APPROVED			TITLE	
MATERIAL				
TREATMENT				
UNLESS OTHERWISE SPECIFIED DIMENSIONS ARE IN MILLIMETERS			SIZE A4	DWG NO
1st ANGLE ANGLES ±0.1°			REV	
2 PL ±0.02 3 PL ±0.005			FILE NAME: Machining_Jig.dft	
SCALE:		WEIGHT:	SHEET 6 OF 7	

REVISION HISTORY			
REV	DESCRIPTION	DATE	APPROVED

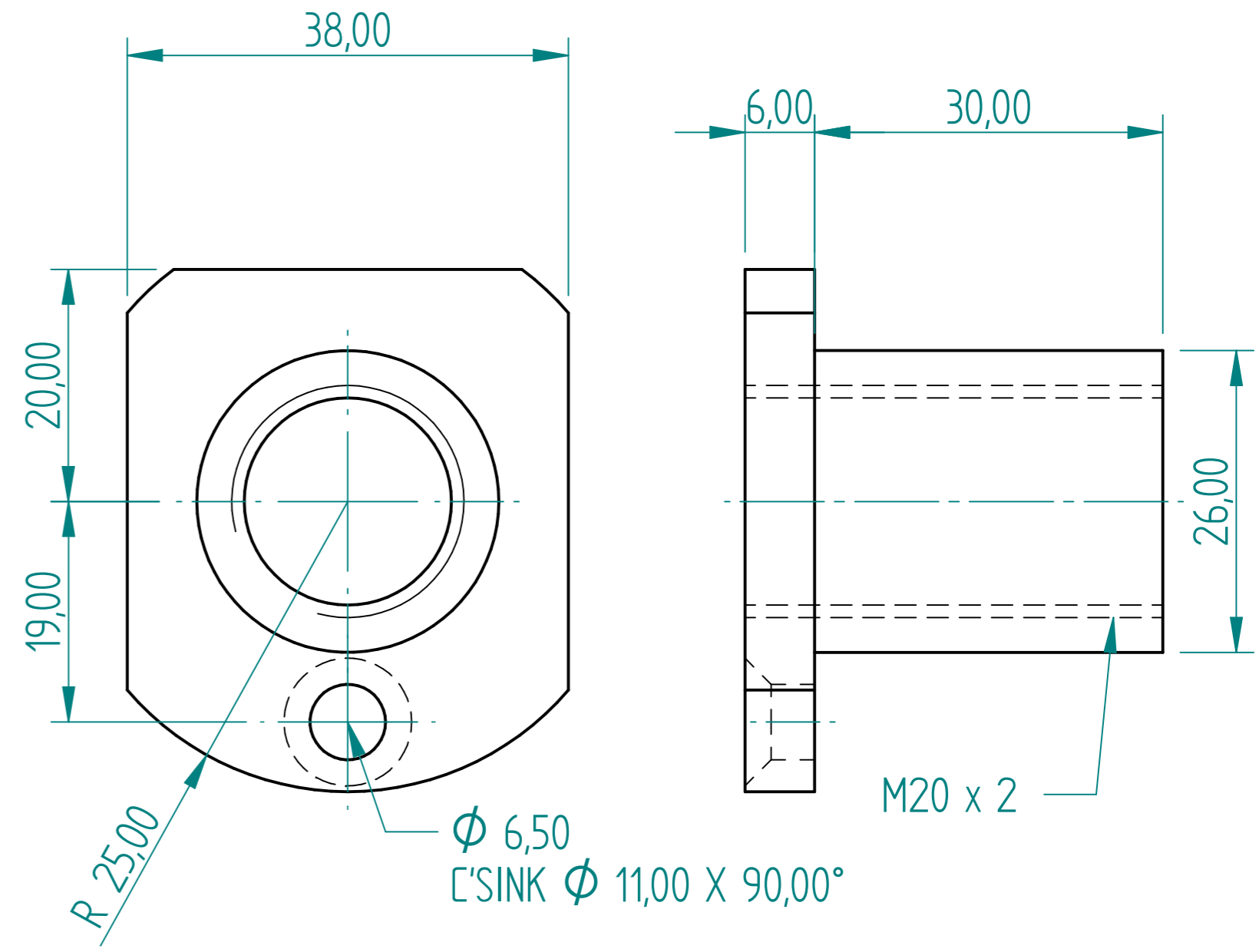
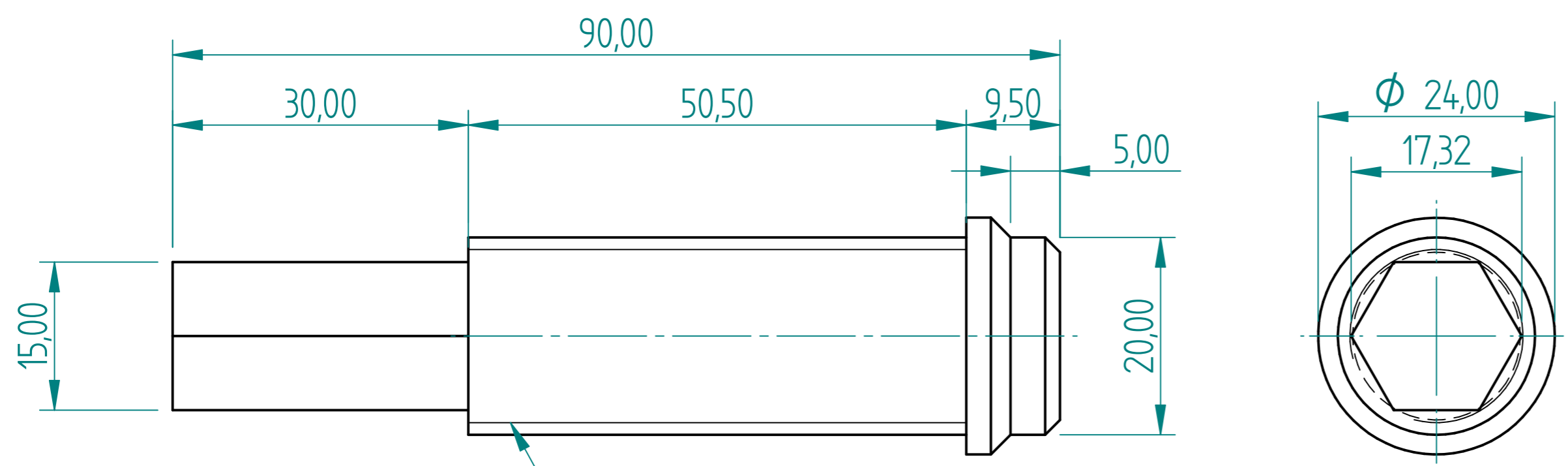
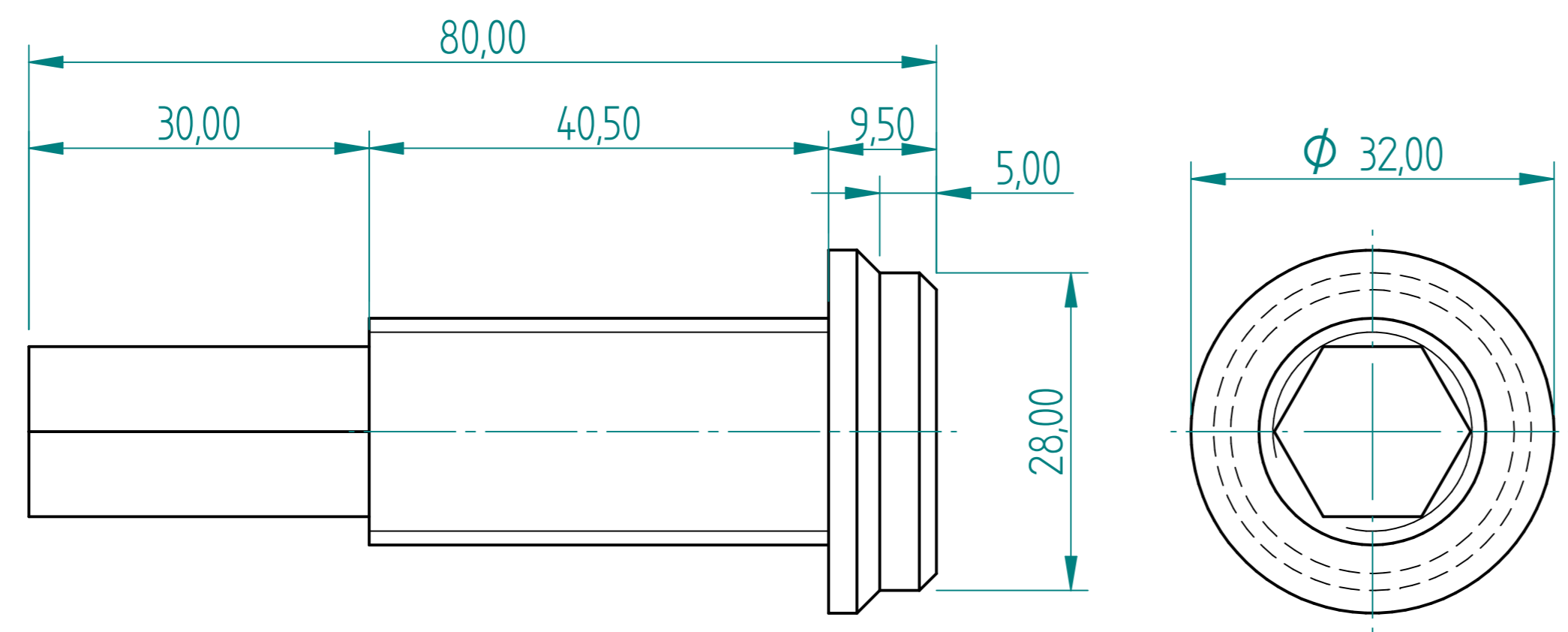
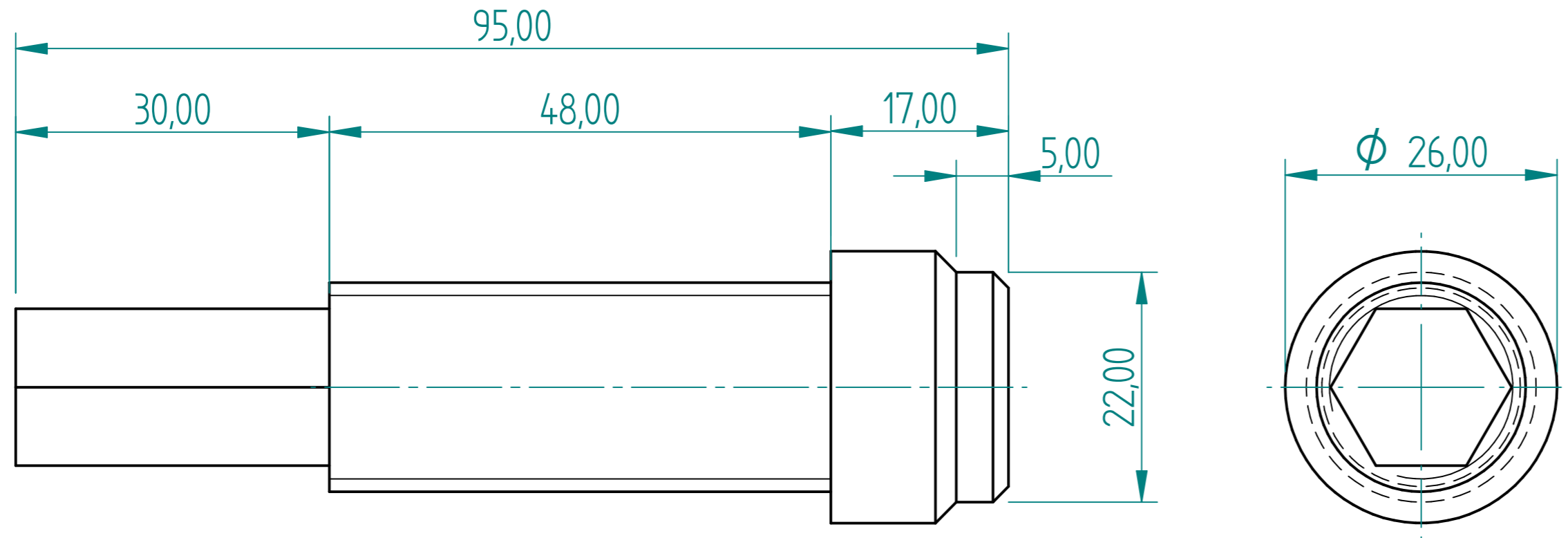

6 of

M20 x 2

SP Bonnet Locating Pin 2 of each

	NAME	DATE	PREMAC	
DRAWN	Dan	08/08/22		
APPROVED			TITLE	
MATERIAL			SIZE	DWG NO
TREATMENT			A4	
UNLESS OTHERWISE SPECIFIED DIMENSIONS ARE IN MILLIMETERS			FILE NAME: Machining Jig.dft	REV
1st ANGLE 2 PL ±0.02 3 PL ±0.005			SCALE:	WEIGHT:
			SHEET 7 OF 7	