

REVISION HISTORY			
REV	DESCRIPTION	DATE	APPROVED

	NAME	DATE	PREMAC	
DRAWN	Dan	02/02/11		
APPROVED			TITLE	
MATERIAL				
TREATMENT			UNLESS OTHERWISE SPECIFIED DIMENSIONS ARE IN MILLIMETERS ANGLES ±0.1° <small>1st ANGLE</small>	
			2 PL ±0.02 3 PL ±0.005	SIZE A4
			SCALE:	DWG NO
			WEIGHT:	REV
			SHEET 1 OF 2	FILE NAME: Selector Valve 80 M.dft

REVISION HISTORY			
REV	DESCRIPTION	DATE	APPROVED

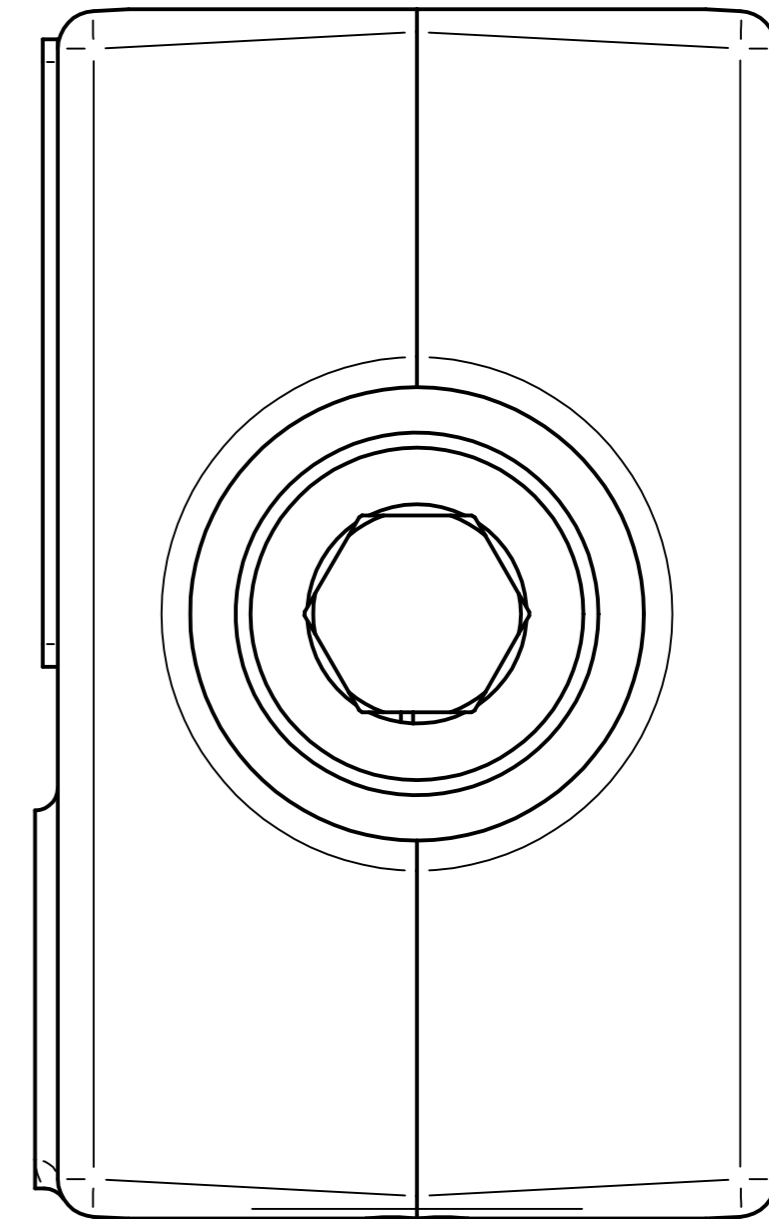
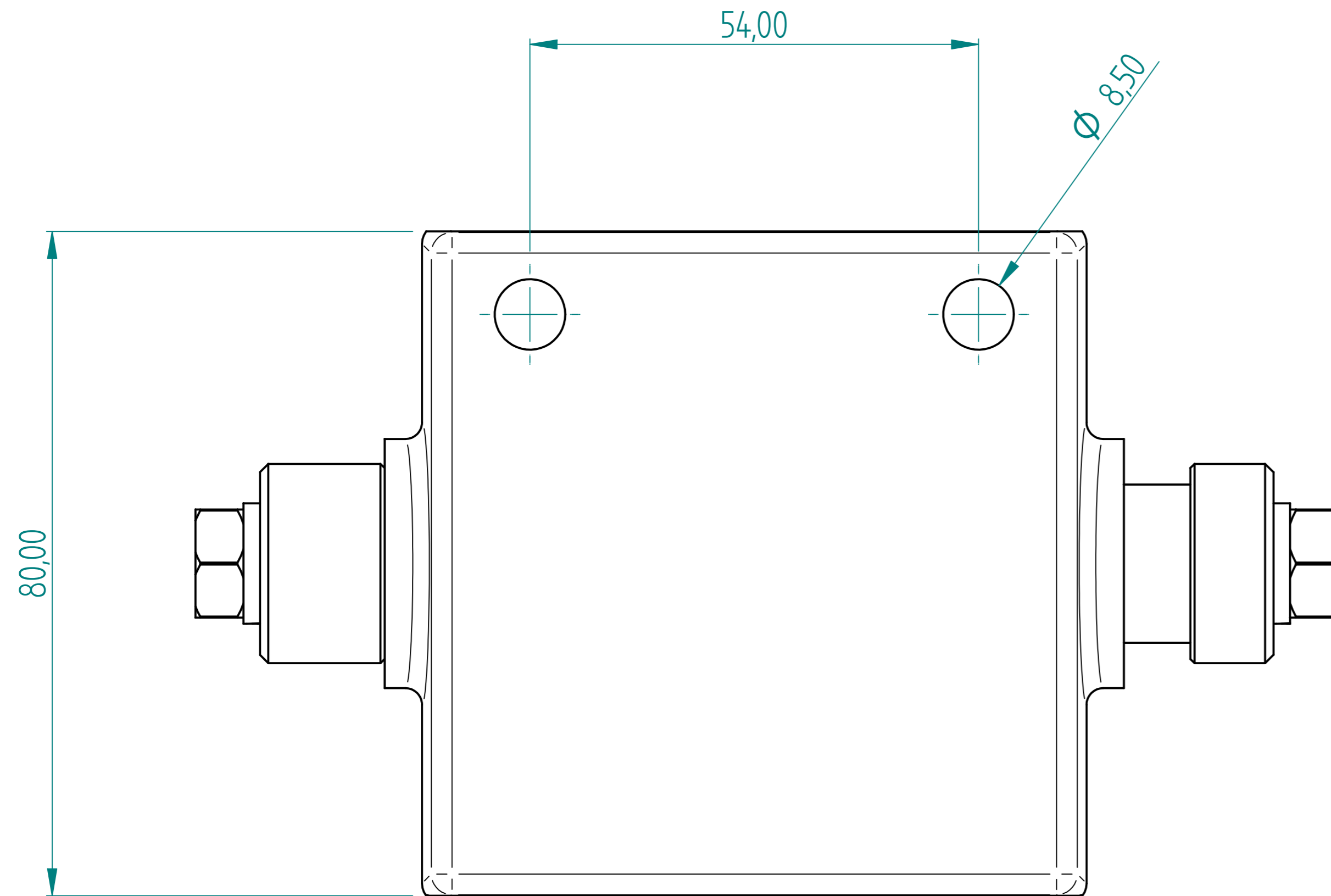

PART No SVH-10-NR

PORTS SAE#10 O-RING BOSS
 FLOW RATE 60 L/min
 PRESSURE 300 Bar

	NAME	DATE	PREMAC	
DRAWN	Dan	02/02/11		
APPROVED				
MATERIAL				
TREATMENT			TITLE	
UNLESS OTHERWISE SPECIFIED DIMENSIONS ARE IN MILLIMETERS			SIZE A4	DWG NO
1st ANGLE ANGLES ±0,1°			FILE NAME: Selector Valve 80 M.dft	REV
2 PL ±0.02 3 PL ±0.005			SCALE:	WEIGHT:
			SHEET 2 OF 2	