

| REVISION HISTORY |             |      |          |
|------------------|-------------|------|----------|
| REV              | DESCRIPTION | DATE | APPROVED |
|                  |             |      |          |

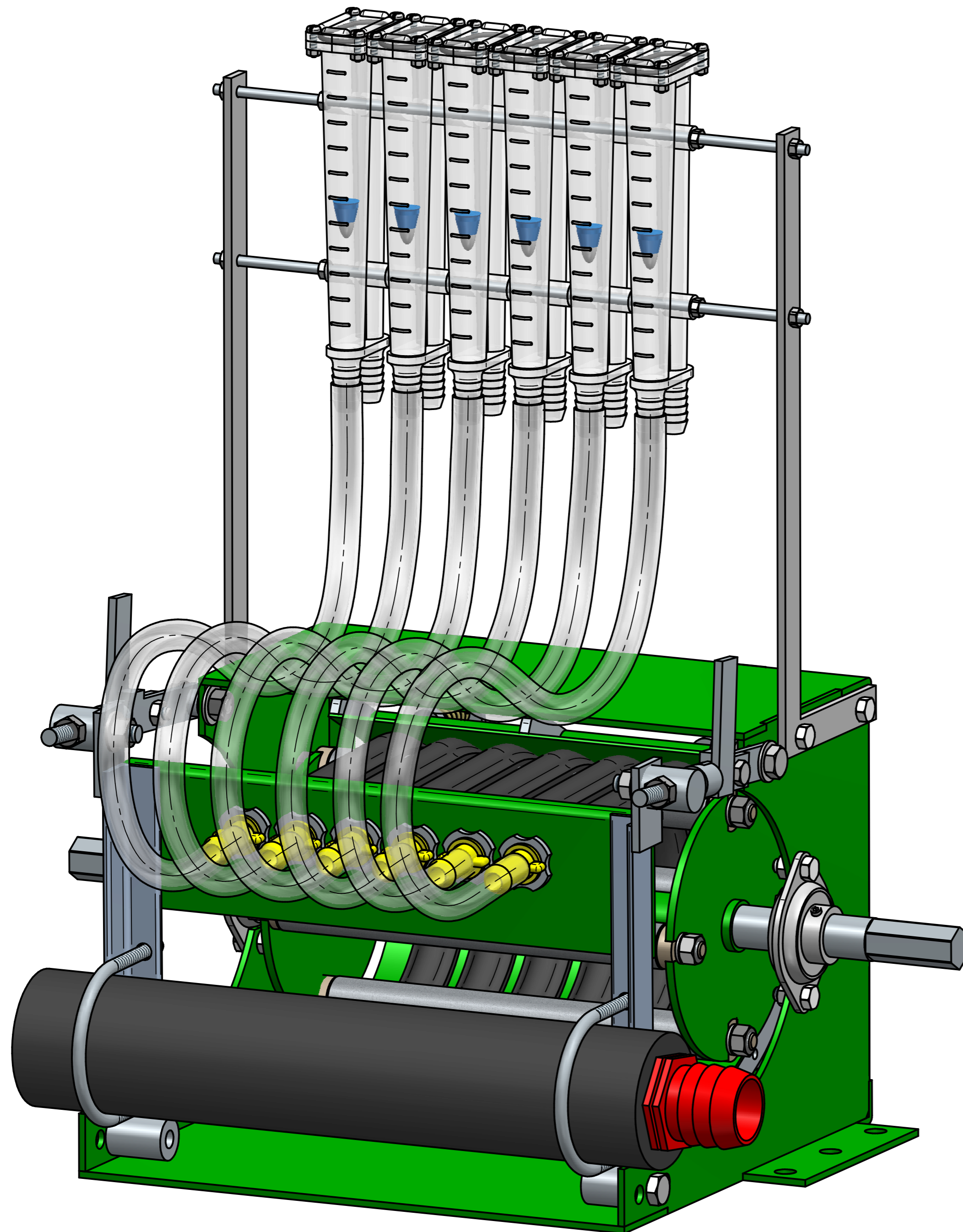

| Item Number | Title           | Quantity |
|-------------|-----------------|----------|
| 1*          | Frame           | 1        |
| 2*          | Drum            | 1        |
| 3*          | Front Plate     | 1        |
| 4*          | Hinge           | 1        |
| 5*          | Flow Indicators | 1        |
| 6*          | Hinge L         | 1        |
| 7*          | Hinge           | 1        |
| 8*          | Hinge           | 1        |
| 9*          | Hinge           | 1        |
| 10*         | Hinge           | 1        |
| 11*         | Hinge           | 1        |
| 12*         | Hinge           | 1        |
| 13*         | Back Plate      | 1        |
| 14*         | M10-30          | 2        |

|   |      |          |                             |         |               |
|---|------|----------|-----------------------------|---------|---------------|
|   | NAME | DATE     | <b>AGRIGEL</b>              |         |               |
| DRAWN   | Dan  | 01/19/14 |                             |         |               |
| APPROVED  |      |          |                             |         |               |
| MATERIAL  |      |          |                             |         |               |
| TREATMENT   |      |          | TITLE                       |         |               |
|   |      |          | Squeeze Pump                |         |               |
| UNLESS OTHERWISE SPECIFIED<br>DIMENSIONS ARE IN MILLIMETERS |      |          | SIZE<br>A4                  | DWG NO  | REV           |
| 1st ANGLE<br>ANGLES ±0.1°                                   |      |          | FILE NAME: Squeeze Pump.dft |         |               |
| 2 PL ±0.02 3 PL ±0.005                                      |      |          | SCALE:                      | WEIGHT: | SHEET 1 OF 15 |

| REVISION HISTORY |             |      |          |
|------------------|-------------|------|----------|
| REV              | DESCRIPTION | DATE | APPROVED |
|                  |             |      |          |

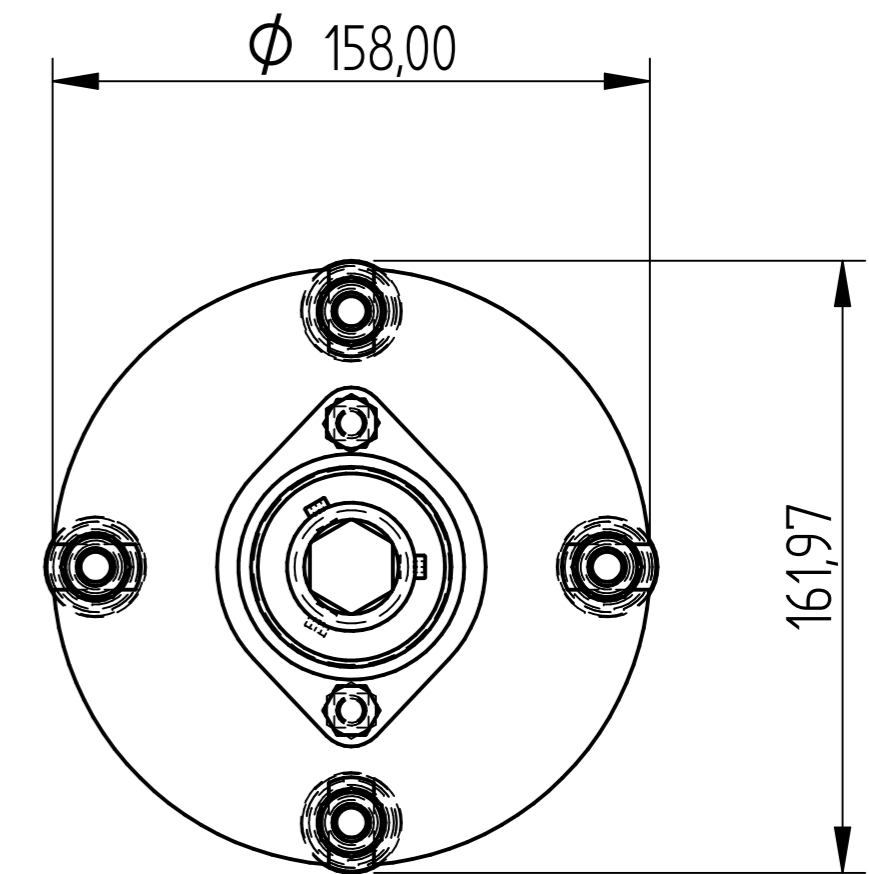
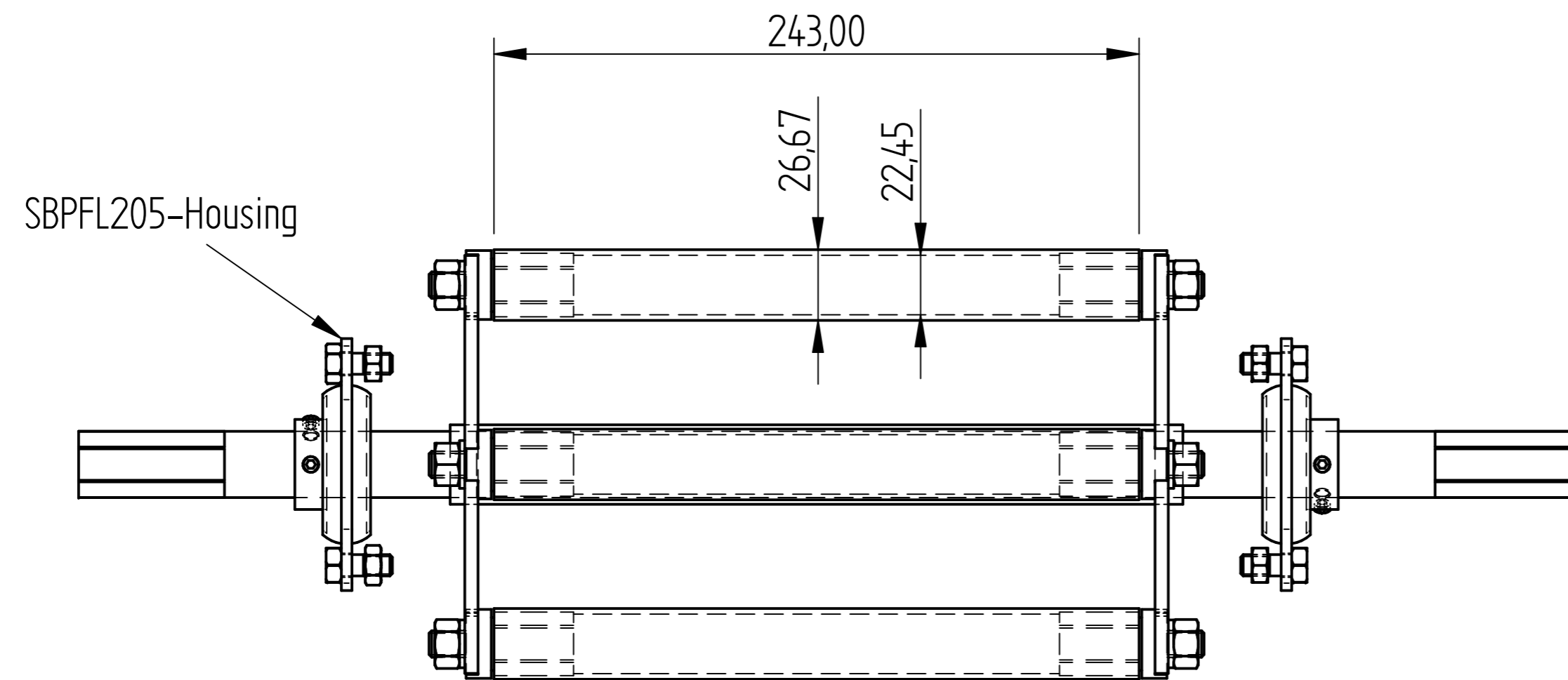

|   |      |          |                             |         |
|---|------|----------|-----------------------------|---------|
|   | NAME | DATE     | <b>AGRIGEL</b>              |         |
| DRAWN   | Dan  | 01/19/14 |                             |         |
| APPROVED  |      |          |                             |         |
| MATERIAL  |      |          |                             |         |
| TREATMENT   |      |          | TITLE                       |         |
| UNLESS OTHERWISE SPECIFIED<br>DIMENSIONS ARE IN MILLIMETERS |      |          | SIZE<br>A4                  | DWG NO  |
| 1 <sup>st</sup> ANGLE<br>2 PL ±0.02 3 PL ±0.005             |      |          | FILE NAME: Squeeze Pump.dft | REV     |
|   |      |          | SCALE:                      | WEIGHT: |
|   |      |          | SHEET 2 OF 15               |         |

| REVISION HISTORY |             |      |          |
|------------------|-------------|------|----------|
| REV              | DESCRIPTION | DATE | APPROVED |
|                  |             |      |          |

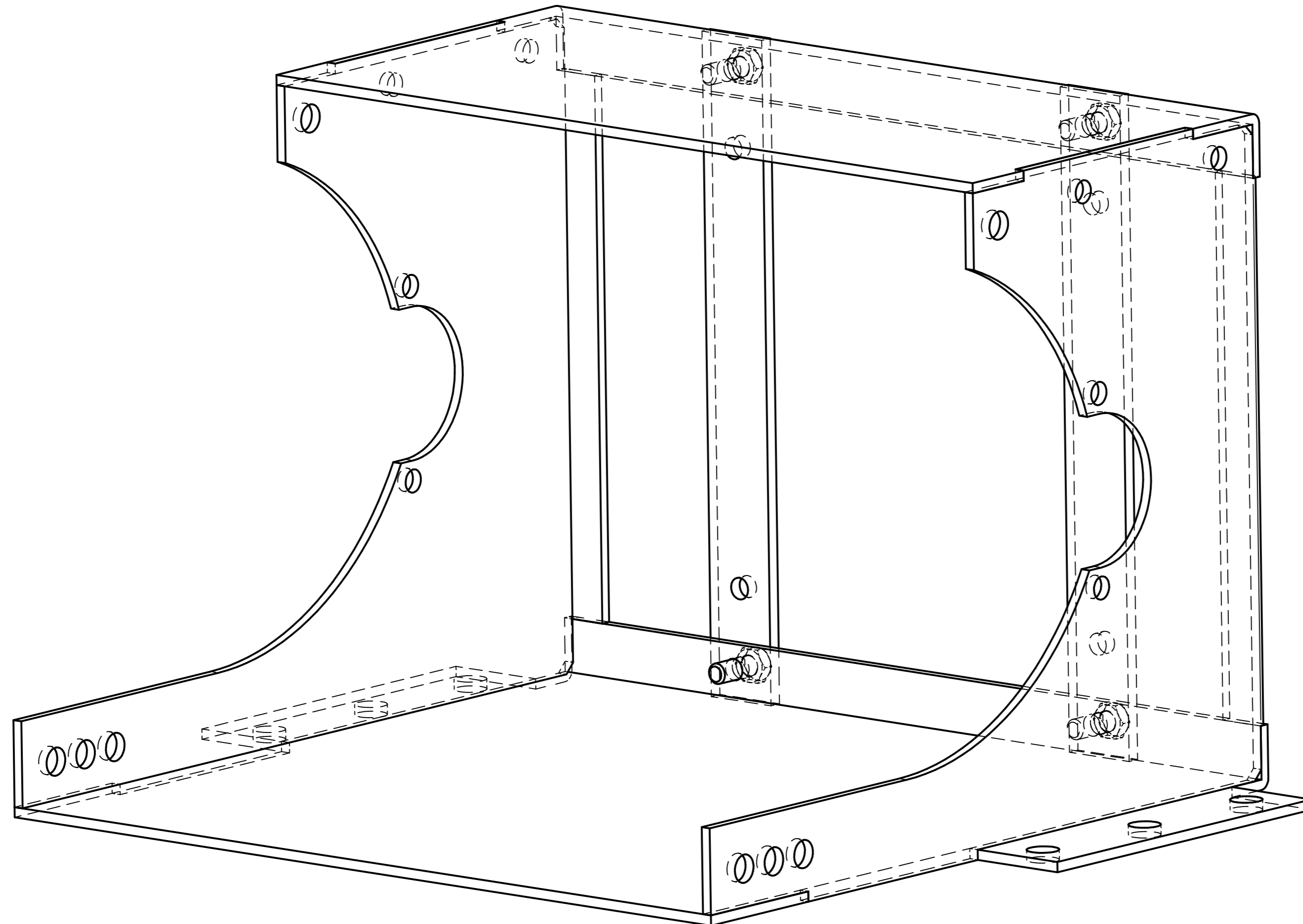

FRAME

|   |      |          |                             |         |               |
|---|------|----------|-----------------------------|---------|---------------|
|   | NAME | DATE     | <b>AGRIGEL</b>              |         |               |
| DRAWN   | Dan  | 01/19/14 |                             |         |               |
| APPROVED  |      |          | TITLE<br>Squeeze Pump       |         |               |
| MATERIAL  |      |          |                             |         |               |
| TREATMENT   |      |          | SIZE<br>A4                  | DWG NO  | REV           |
| UNLESS OTHERWISE SPECIFIED<br>DIMENSIONS ARE IN MILLIMETERS |      |          | FILE NAME: Squeeze Pump.dft |         |               |
| 1 <sup>st</sup> ANGLE<br>2 PL ±0.02 3 PL ±0.005             |      |          | SCALE:                      | WEIGHT: | SHEET 3 OF 15 |

| REVISION HISTORY |             |      |          |
|------------------|-------------|------|----------|
| REV              | DESCRIPTION | DATE | APPROVED |
|                  |             |      |          |

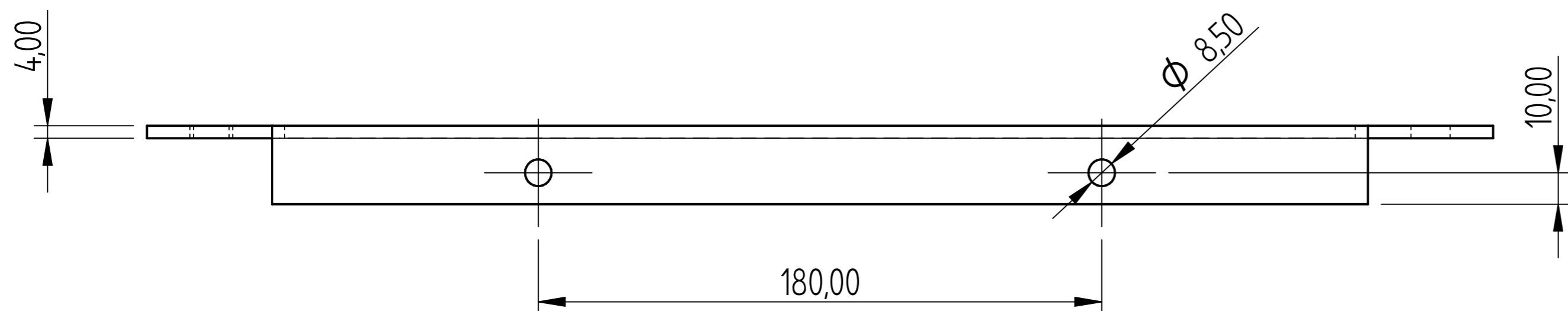
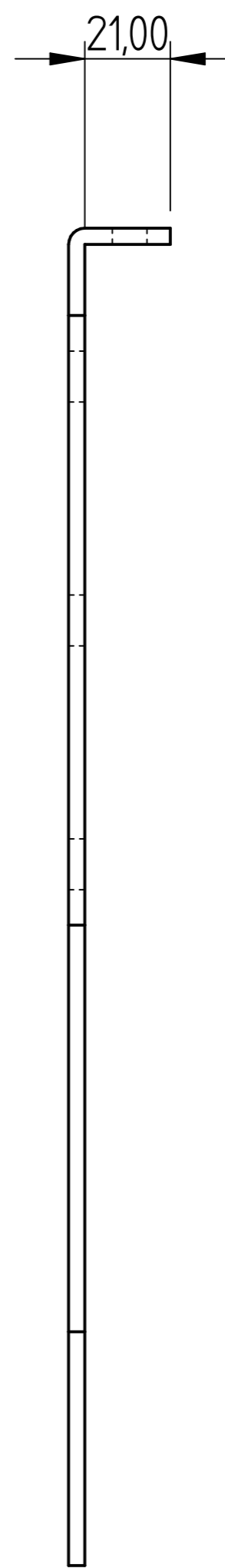
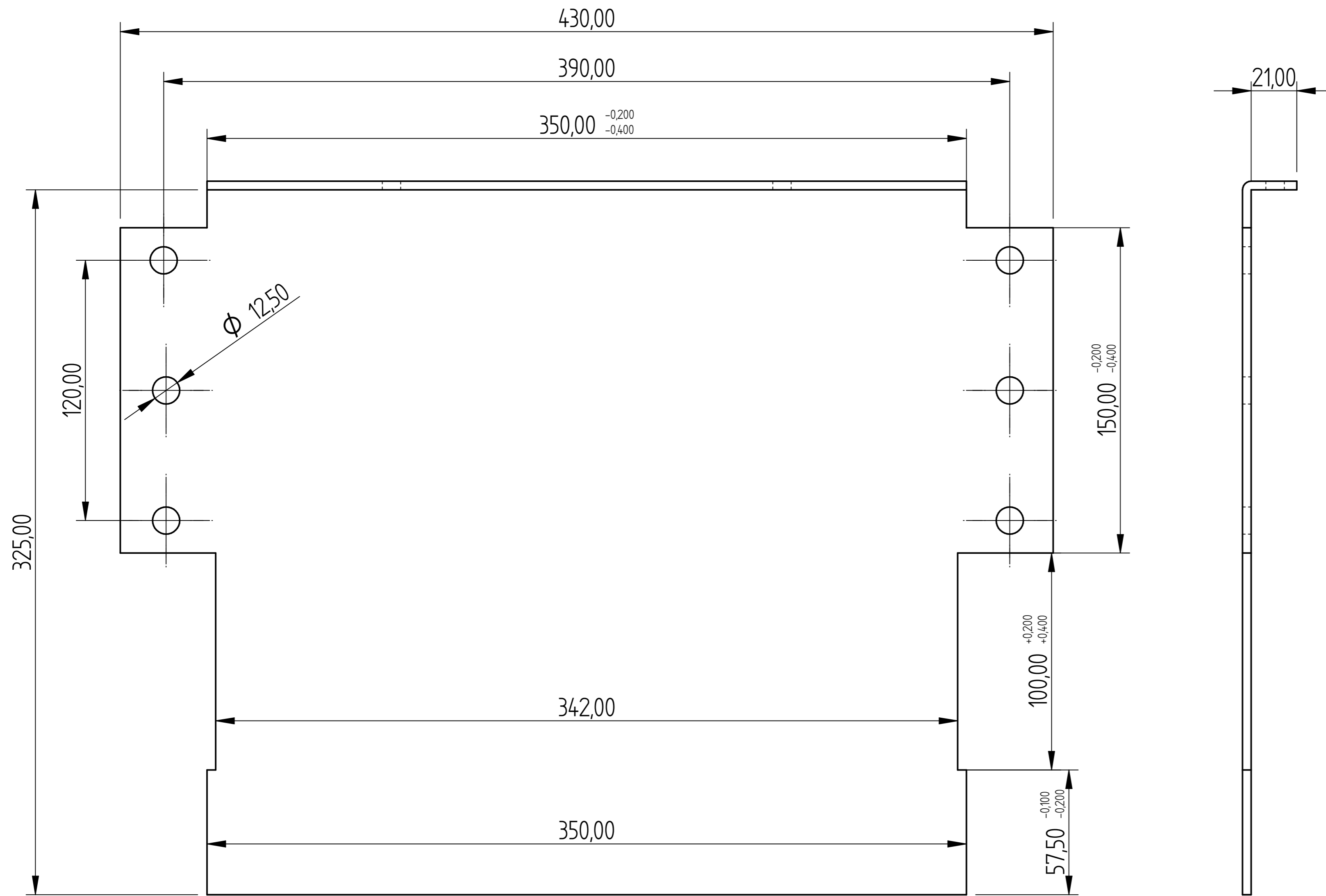

BASE PLATE

|   |      |          |                             |         |
|---|------|----------|-----------------------------|---------|
| DRAWN   | NAME | DATE     | <b>AGRIGEL</b>              |         |
| APPROVED  | Dan  | 01/19/14 | TITLE                       |         |
| MATERIAL  |      |          | Squeeze Pump                |         |
| TREATMENT   |      |          | SIZE                        | DWG NO  |
| UNLESS OTHERWISE SPECIFIED<br>DIMENSIONS ARE IN MILLIMETERS |      |          | A4                          | REV     |
| 1 <sup>st</sup> ANGLE                                       |      |          | FILE NAME: Squeeze Pump.dft |         |
| 2 PL ±0.02 3 PL ±0.005                                      |      |          | SCALE:                      | WEIGHT: |
|   |      |          | SHEET 4 OF 15               |         |

| REVISION HISTORY |             |      |          |
|------------------|-------------|------|----------|
| REV              | DESCRIPTION | DATE | APPROVED |
|                  |             |      |          |

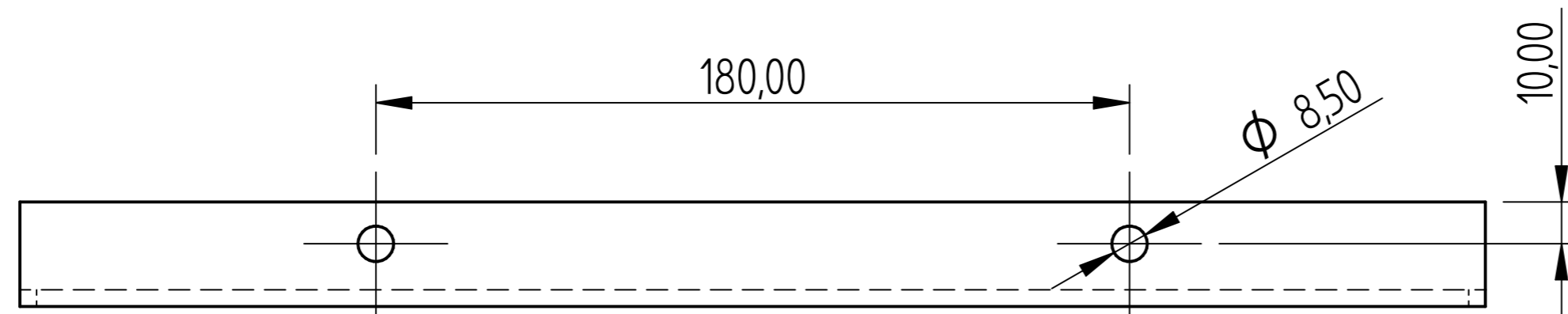
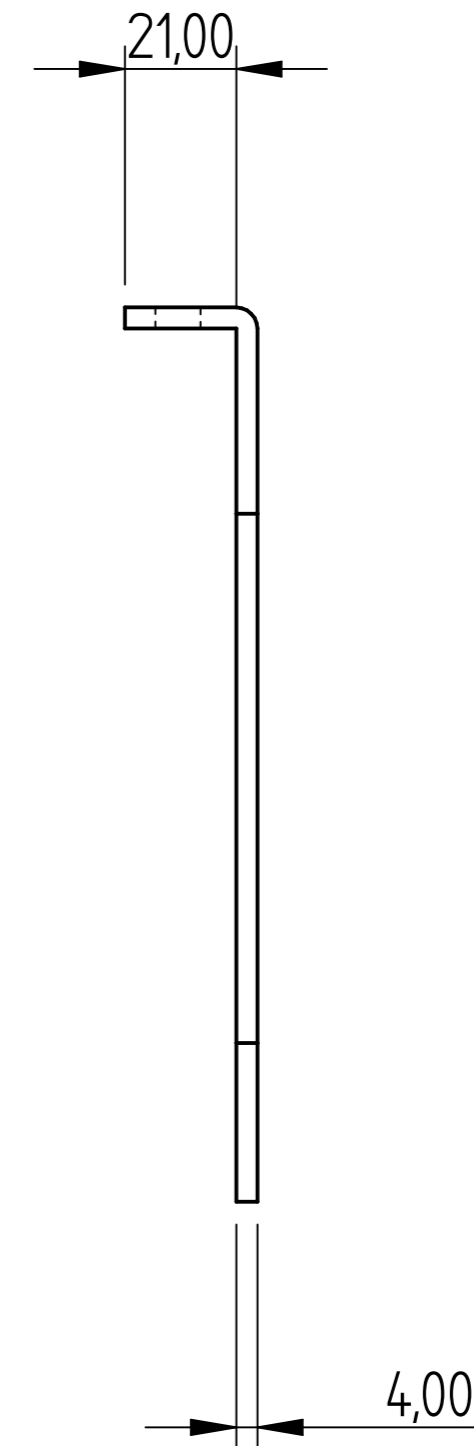
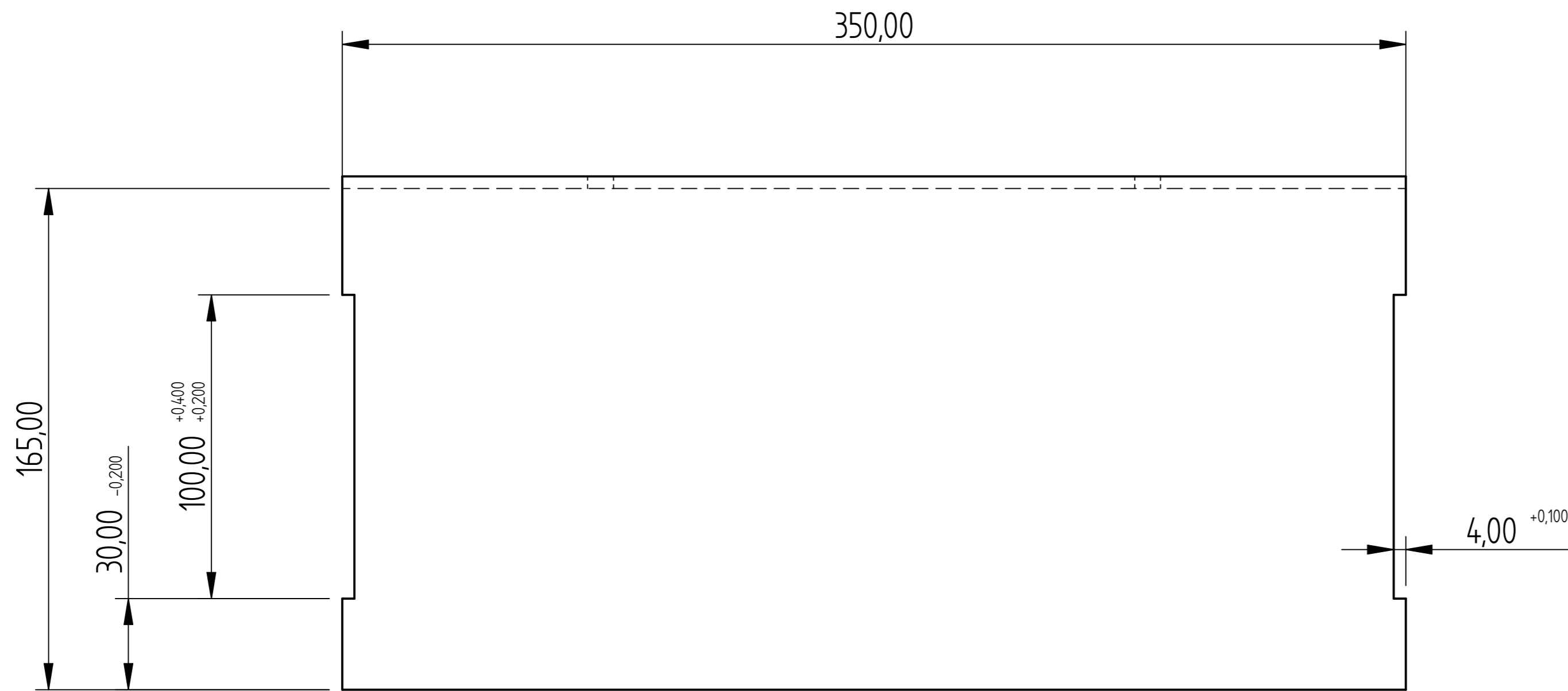

TOP PLATE

|   |      |          |                             |               |
|---|------|----------|-----------------------------|---------------|
|   | NAME | DATE     | <b>AGRIGEL</b>              |               |
| DRAWN   | Dan  | 01/19/14 | TITLE                       |               |
| APPROVED  |      |          | Squeeze Pump                |               |
| MATERIAL  |      |          | SIZE                        | DWG NO        |
| TREATMENT   |      |          | A4                          |               |
| UNLESS OTHERWISE SPECIFIED<br>DIMENSIONS ARE IN MILLIMETERS |      |          | FILE NAME: Squeeze Pump.dft | REV           |
| 1 <sup>st</sup> ANGLE                                       |      |          | SCALE:                      | WEIGHT:       |
| 2 PL ±0.02 3 PL ±0.005                                      |      |          |                             | SHEET 5 OF 15 |

| REVISION HISTORY |             |      |          |
|------------------|-------------|------|----------|
| REV              | DESCRIPTION | DATE | APPROVED |
|                  |             |      |          |

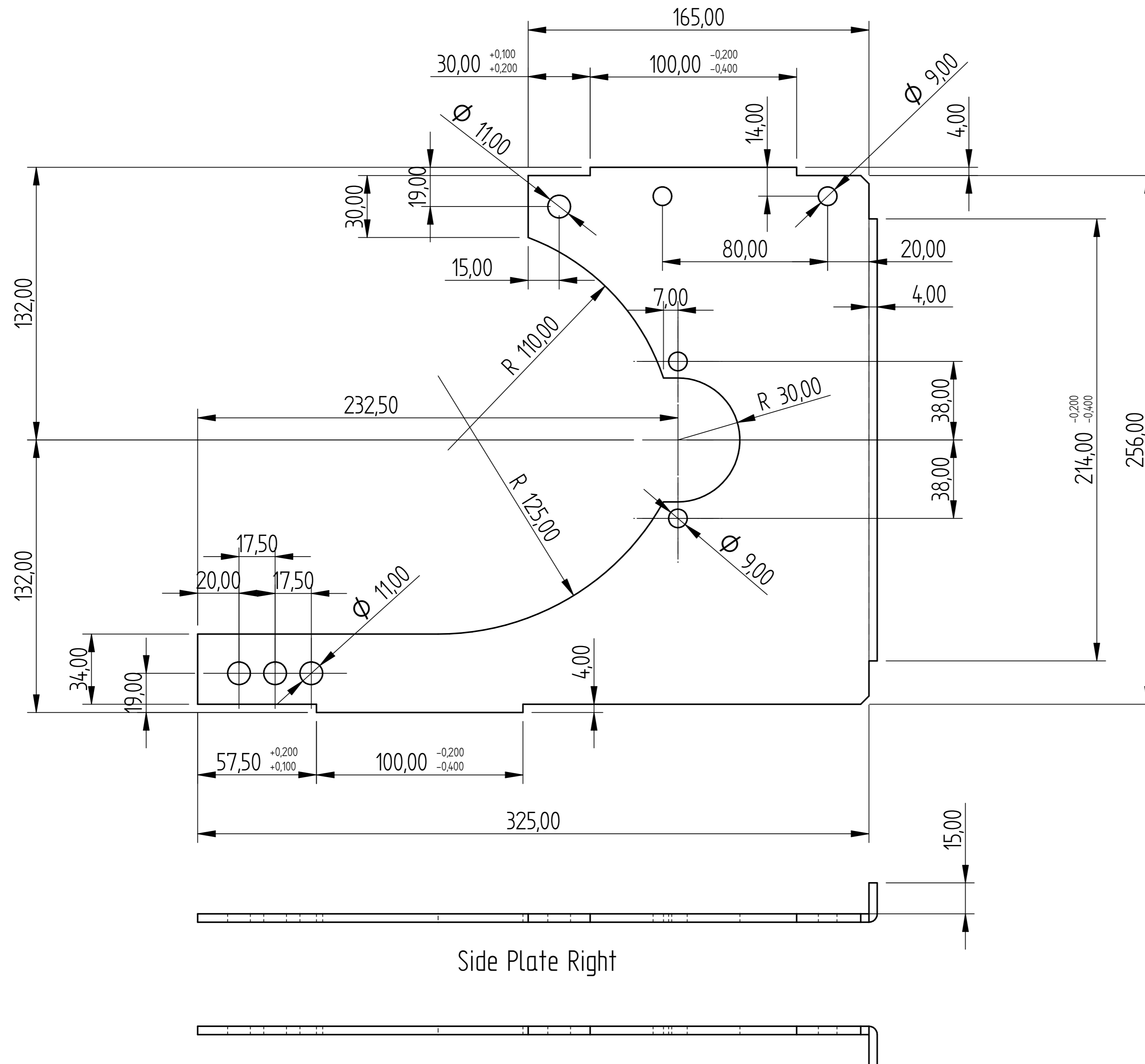

Side Plate Right

Side Plate Left

|   |      |          |                             |         |               |
|---|------|----------|-----------------------------|---------|---------------|
|   | NAME | DATE     | <b>AGRIGEL</b>              |         |               |
| DRAWN   | Dan  | 01/19/14 |                             |         |               |
| APPROVED  |      |          | TITLE<br>Squeeze Pump       |         |               |
| MATERIAL  |      |          |                             |         |               |
| TREATMENT   |      |          | SIZE<br>A4                  | DWG NO  | REV           |
| UNLESS OTHERWISE SPECIFIED<br>DIMENSIONS ARE IN MILLIMETERS |      |          | FILE NAME: Squeeze Pump.dft |         |               |
| 1 <sup>st</sup> ANGLE<br>ANGLES $\pm 0,1^\circ$             |      |          | SCALE:                      | WEIGHT: | SHEET 6 OF 15 |
| 2 PL $\pm 0,02$ 3 PL $\pm 0,005$                            |      |          |                             |         |               |

| REVISION HISTORY |             |      |          |
|------------------|-------------|------|----------|
| REV              | DESCRIPTION | DATE | APPROVED |
|                  |             |      |          |

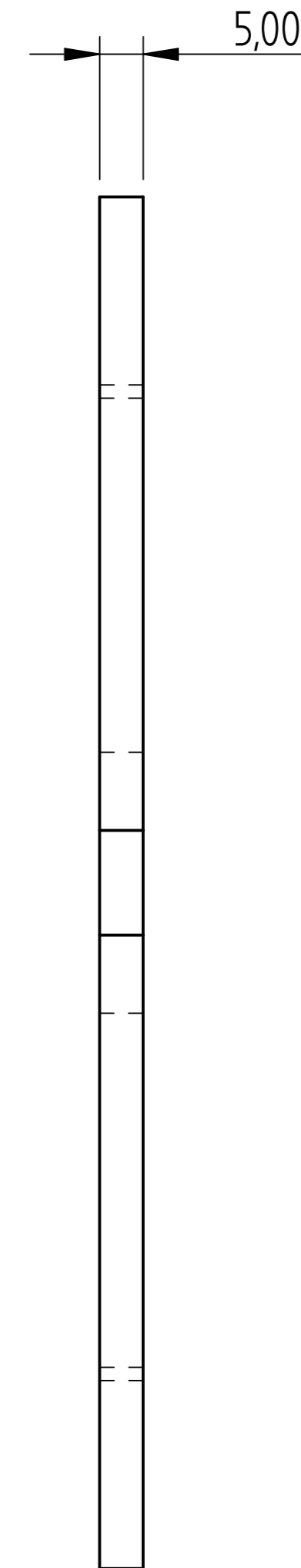
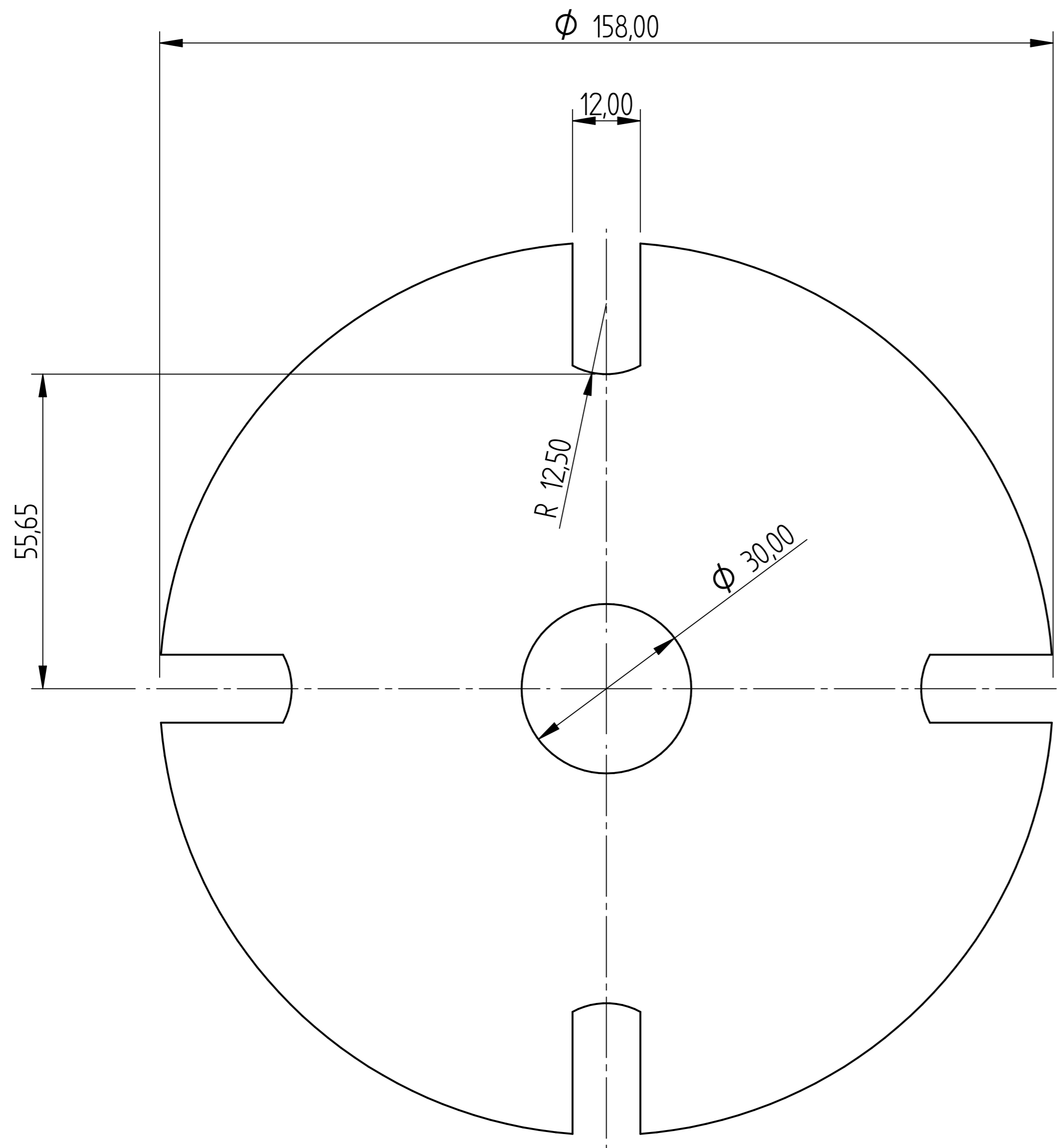

SIDE FLANGE 2 PER FRAME

|   |      |          |                             |         |
|---|------|----------|-----------------------------|---------|
|   | NAME | DATE     | <b>AGRIGEL</b>              |         |
| DRAWN   | Dan  | 01/19/14 |                             |         |
| APPROVED  |      |          |                             |         |
| MATERIAL  |      |          |                             |         |
| TREATMENT   |      |          | TITLE                       |         |
| UNLESS OTHERWISE SPECIFIED<br>DIMENSIONS ARE IN MILLIMETERS |      |          | SIZE<br>A4                  | DWG NO  |
| 1 <sup>st</sup> ANGLE<br>ANGLES ±0.1°                       |      |          | FILE NAME: Squeeze Pump.dft | REV     |
| 2 PL ±0.02 3 PL ±0.005                                      |      |          | SCALE:                      | WEIGHT: |
|   |      |          | SHEET 7 OF 15               |         |

| REVISION HISTORY |             |      |          |
|------------------|-------------|------|----------|
| REV              | DESCRIPTION | DATE | APPROVED |
|                  |             |      |          |

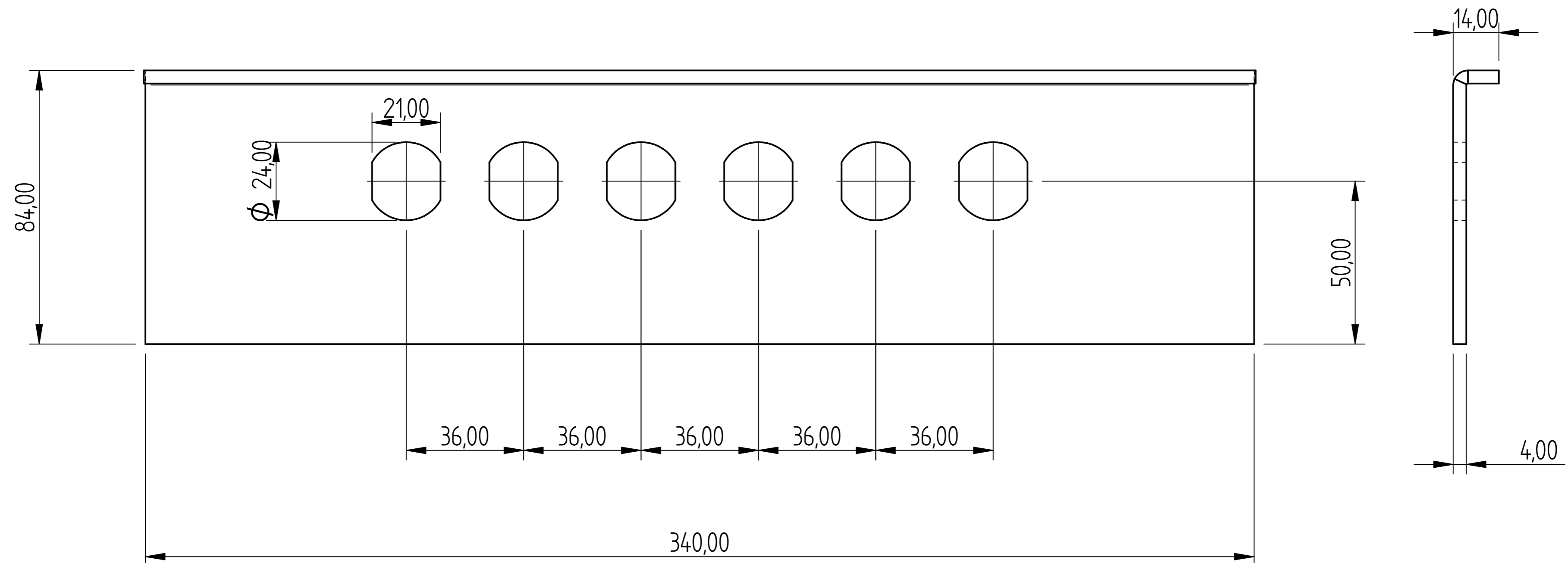

FRONT PLATE

|   |      |          |                             |         |               |
|---|------|----------|-----------------------------|---------|---------------|
|   | NAME | DATE     | <b>AGRIGEL</b>              |         |               |
| DRAWN   | Dan  | 01/19/14 |                             |         |               |
| APPROVED  |      |          | TITLE<br>Squeeze Pump       |         |               |
| MATERIAL  |      |          |                             |         |               |
| TREATMENT   |      |          | SIZE<br>A4                  | DWG NO  | REV           |
| UNLESS OTHERWISE SPECIFIED<br>DIMENSIONS ARE IN MILLIMETERS |      |          | FILE NAME: Squeeze Pump.dft |         |               |
| 1 <sup>st</sup> ANGLE<br>2 PL ±0.02 3 PL ±0.005             |      |          | SCALE:                      | WEIGHT: | SHEET 8 OF 15 |

| REVISION HISTORY |             |      |          |
|------------------|-------------|------|----------|
| REV              | DESCRIPTION | DATE | APPROVED |
|                  |             |      |          |

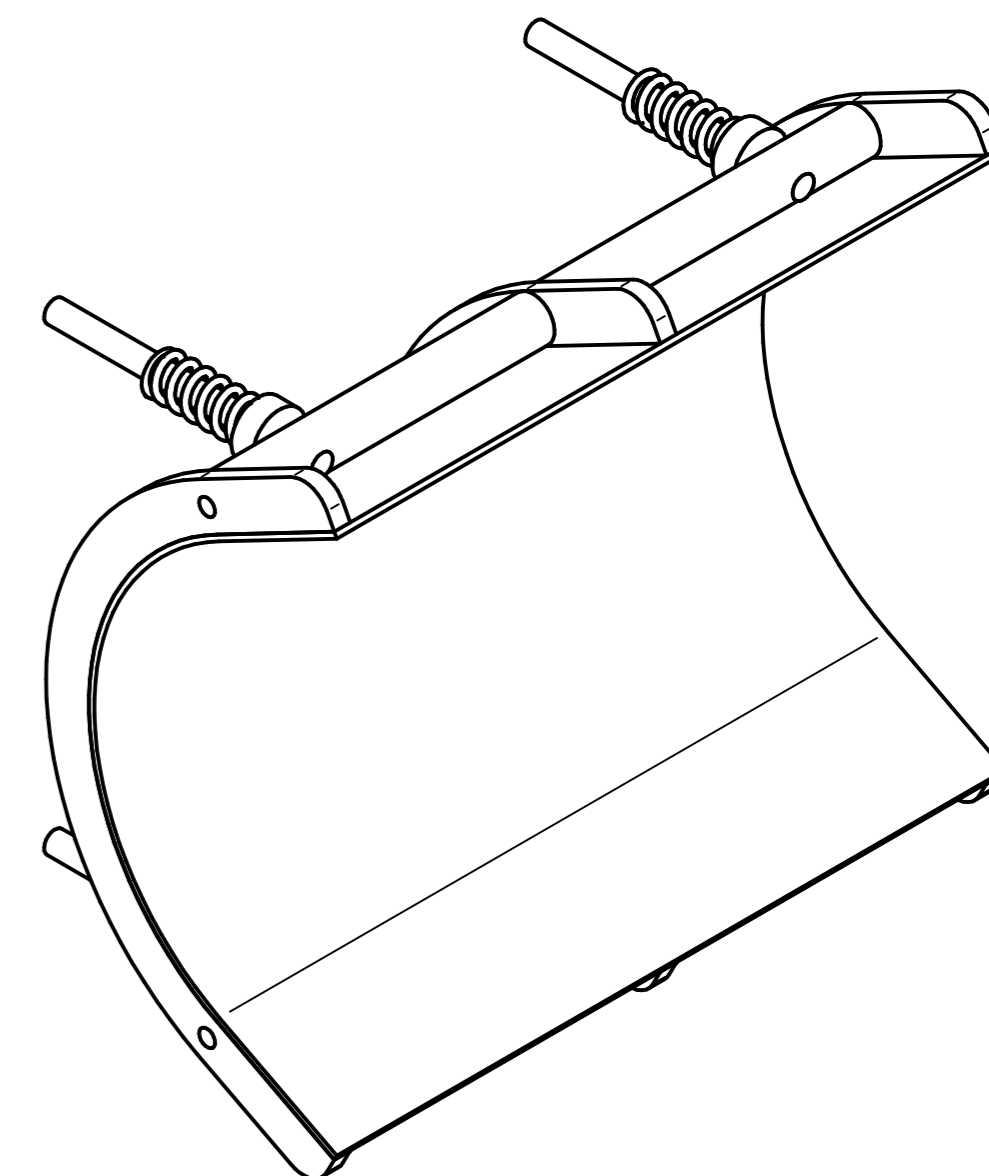
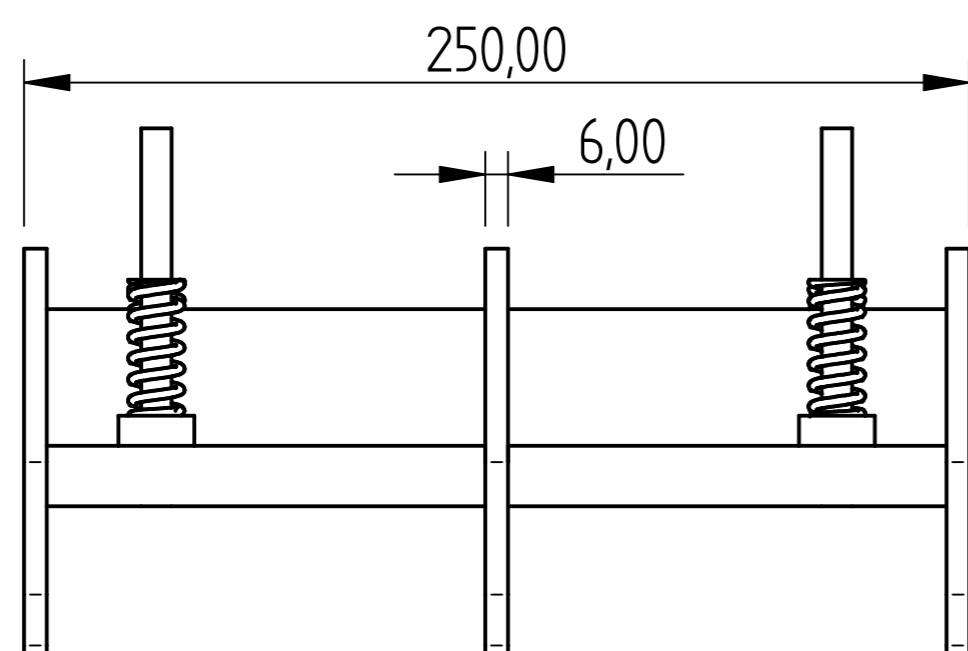
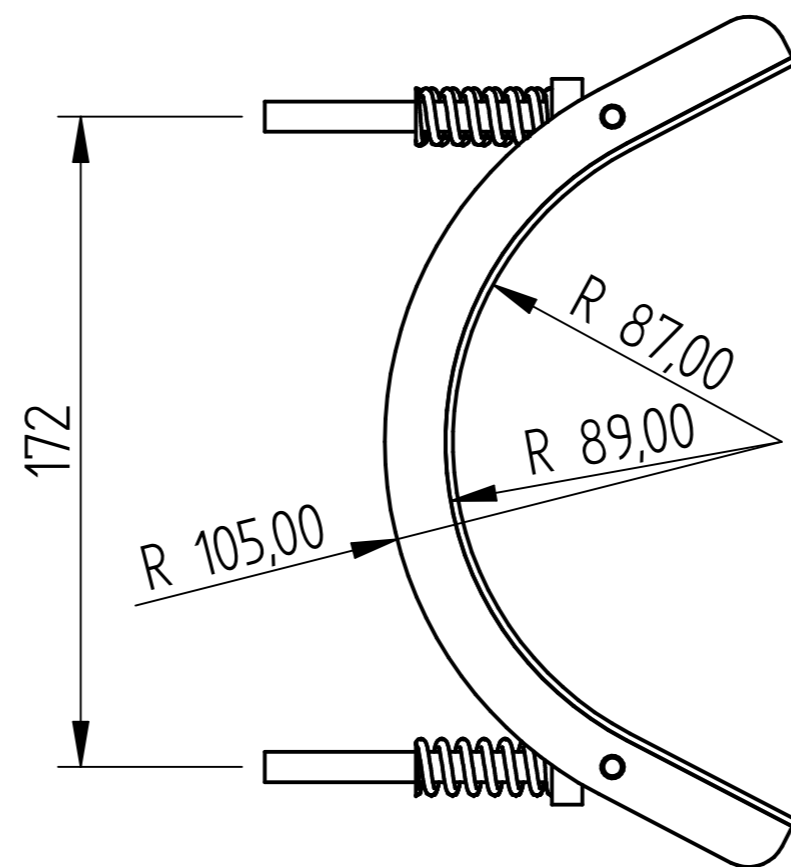
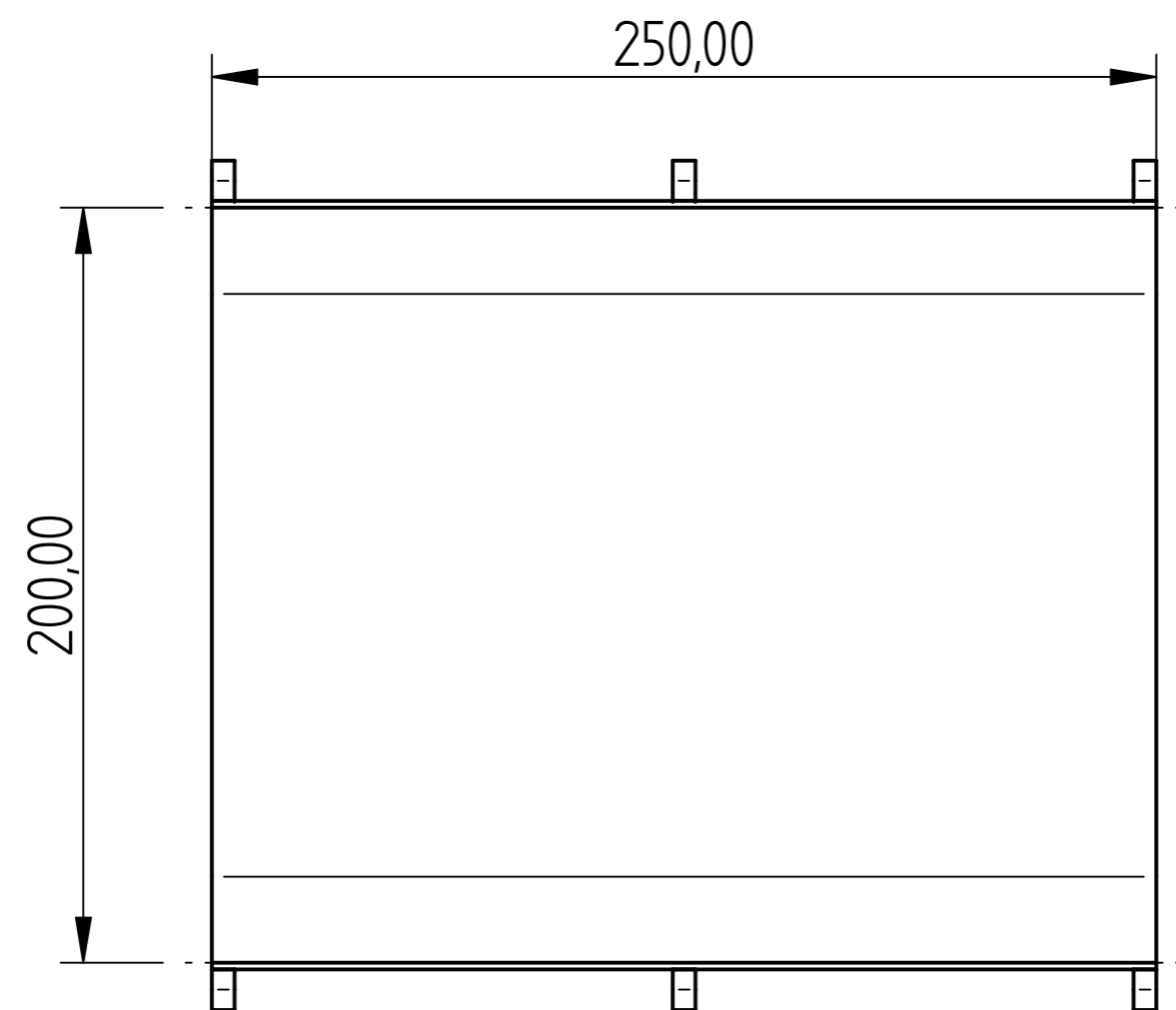

BACK PLATE ASSEMBLY

|   |      |          |                             |         |               |
|---|------|----------|-----------------------------|---------|---------------|
|   | NAME | DATE     | <b>AGRIGEL</b>              |         |               |
| DRAWN   | Dan  | 01/19/14 |                             |         |               |
| APPROVED  |      |          | TITLE<br>Squeeze Pump       |         |               |
| MATERIAL  |      |          |                             |         |               |
| TREATMENT   |      |          | SIZE<br>A4                  | DWG NO  | REV           |
| UNLESS OTHERWISE SPECIFIED<br>DIMENSIONS ARE IN MILLIMETERS |      |          | FILE NAME: Squeeze Pump.dft |         |               |
| 1 <sup>st</sup> ANGLE<br>ANGLES ±0.1°                       |      |          | SCALE:                      | WEIGHT: | SHEET 9 OF 15 |
| 2 PL ±0.02 3 PL ±0.005                                      |      |          |                             |         |               |

| REVISION HISTORY |             |      |          |
|------------------|-------------|------|----------|
| REV              | DESCRIPTION | DATE | APPROVED |
|                  |             |      |          |

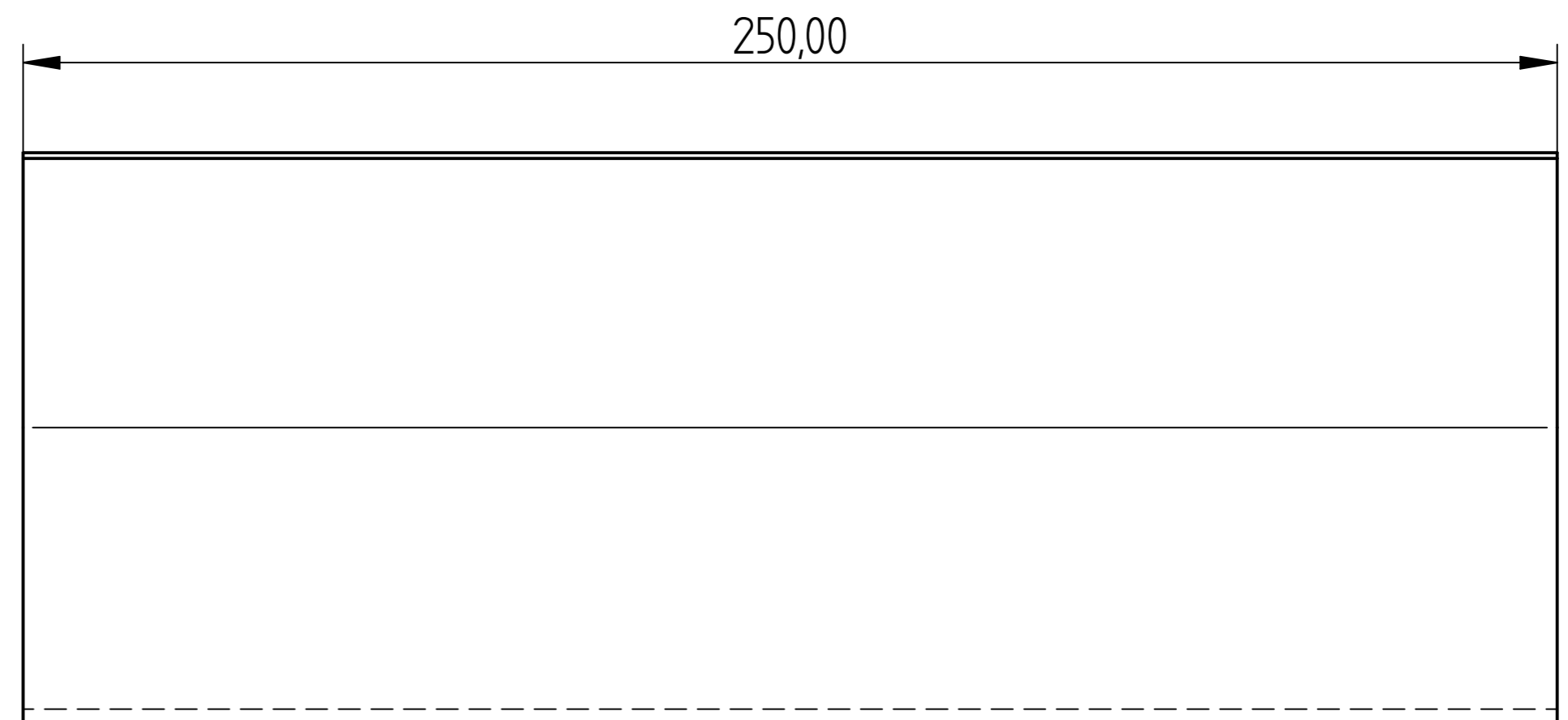
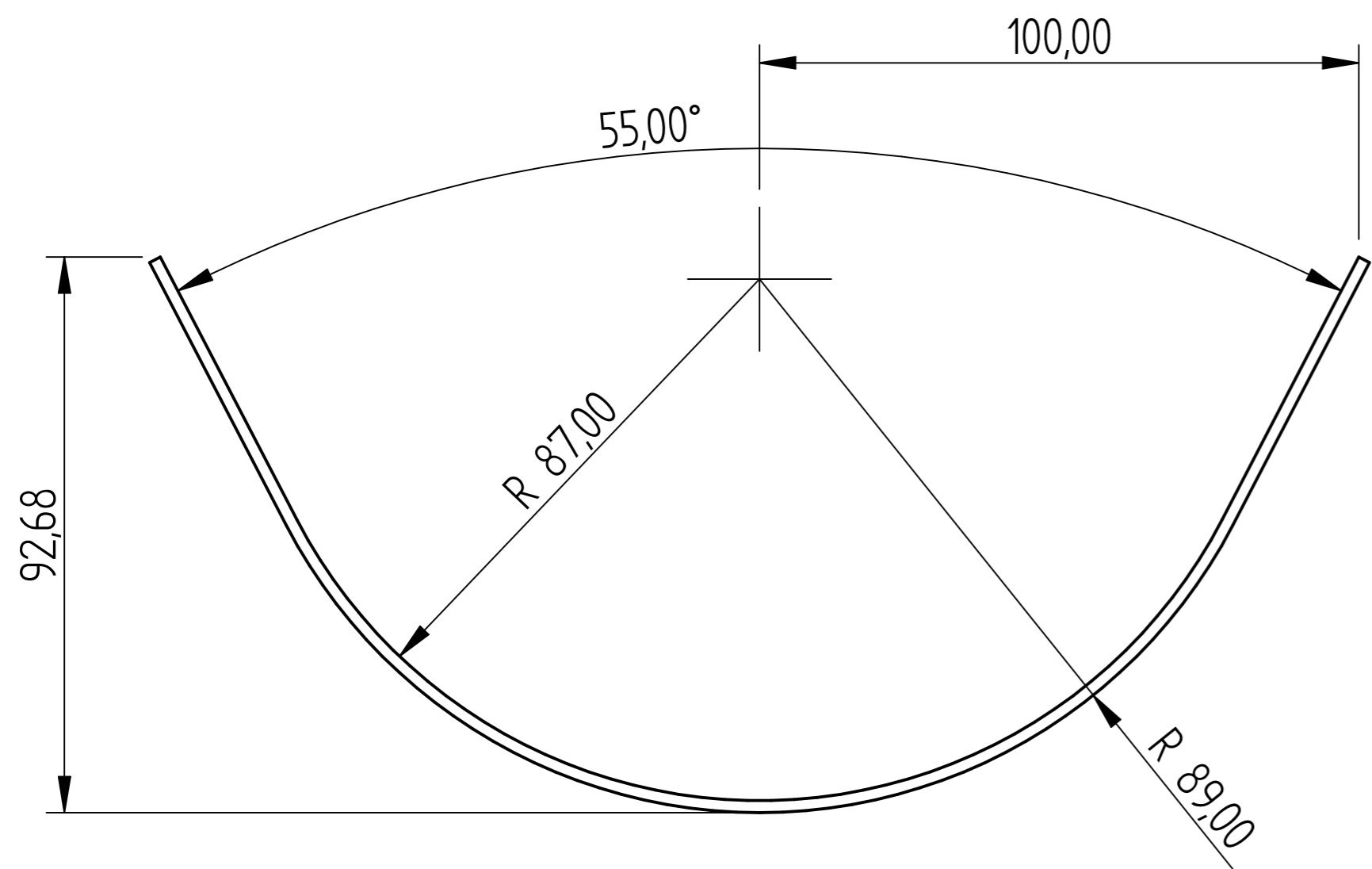

BACK PLATE

|   |      |          |                             |                |
|---|------|----------|-----------------------------|----------------|
|   | NAME | DATE     | <b>AGRIGEL</b>              |                |
| DRAWN   | Dan  | 01/19/14 | TITLE                       |                |
| APPROVED  |      |          | Squeeze Pump                |                |
| MATERIAL  |      |          | SIZE                        | DWG NO         |
| TREATMENT   |      |          | A4                          |                |
| UNLESS OTHERWISE SPECIFIED<br>DIMENSIONS ARE IN MILLIMETERS |      |          | FILE NAME: Squeeze Pump.dft | REV            |
| 1 <sup>st</sup> ANGLE                                       |      |          | SCALE:                      | WEIGHT:        |
| 2 PL ±0.02 3 PL ±0.005                                      |      |          |                             | SHEET 10 OF 15 |

| REVISION HISTORY |             |      |          |
|------------------|-------------|------|----------|
| REV              | DESCRIPTION | DATE | APPROVED |
|                  |             |      |          |

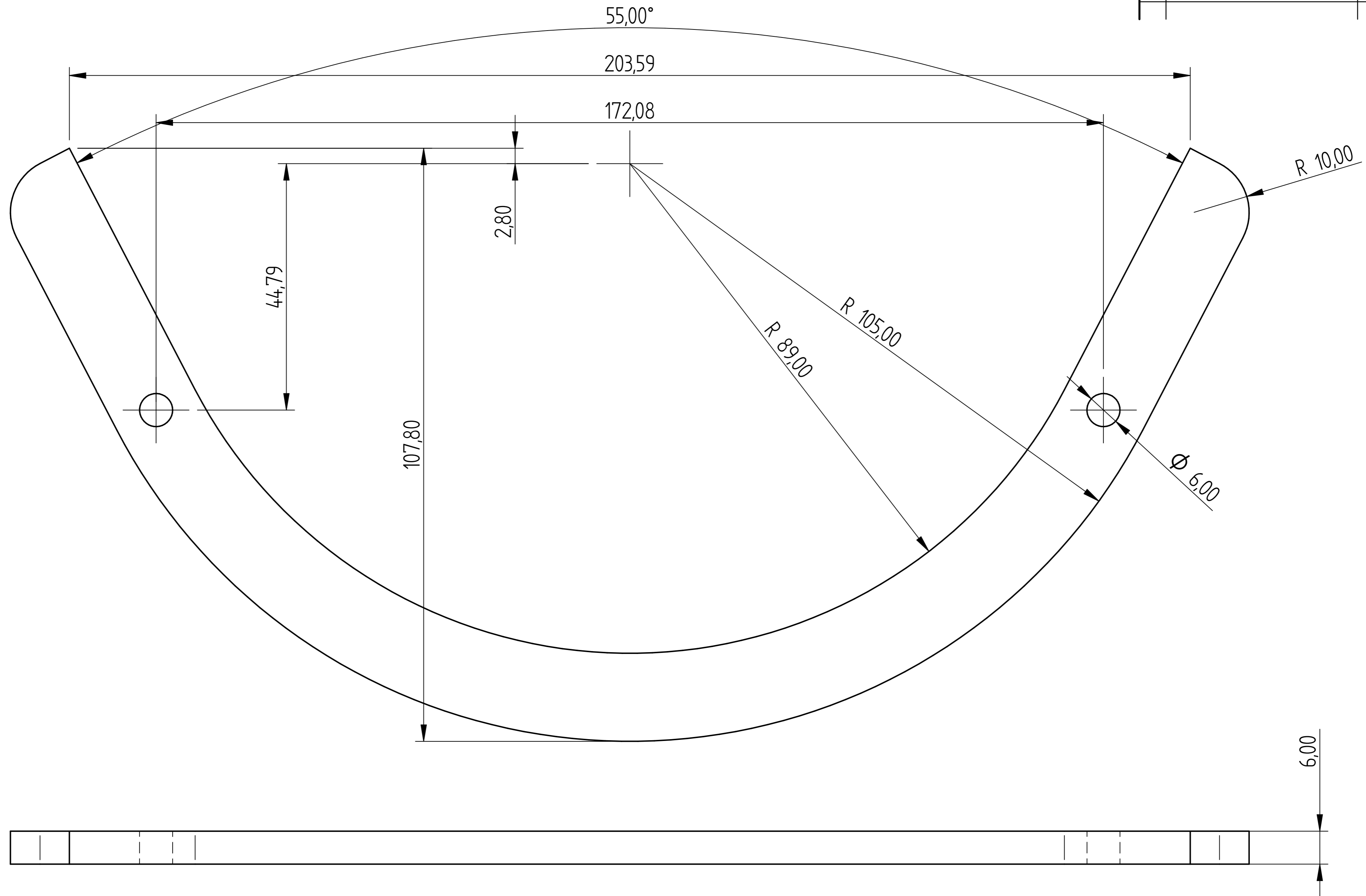

SUPPORT RIB 3 PER FRAME

|   |      |          |                             |         |                |
|---|------|----------|-----------------------------|---------|----------------|
|   | NAME | DATE     | <b>AGRIGEL</b>              |         |                |
| DRAWN   | Dan  | 01/19/14 |                             |         |                |
| APPROVED  |      |          | TITLE<br>Squeeze Pump       |         |                |
| MATERIAL  |      |          |                             |         |                |
| TREATMENT   |      |          | SIZE<br>A4                  | DWG NO  | REV            |
| UNLESS OTHERWISE SPECIFIED<br>DIMENSIONS ARE IN MILLIMETERS |      |          | FILE NAME: Squeeze Pump.dft |         |                |
| 1 <sup>st</sup> ANGLE<br>                                   |      |          | SCALE:                      | WEIGHT: | SHEET 11 OF 15 |
| 2 PL ±0.02 3 PL ±0.005                                      |      |          |                             |         |                |

| REVISION HISTORY |             |      |          |
|------------------|-------------|------|----------|
| REV              | DESCRIPTION | DATE | APPROVED |
|                  |             |      |          |

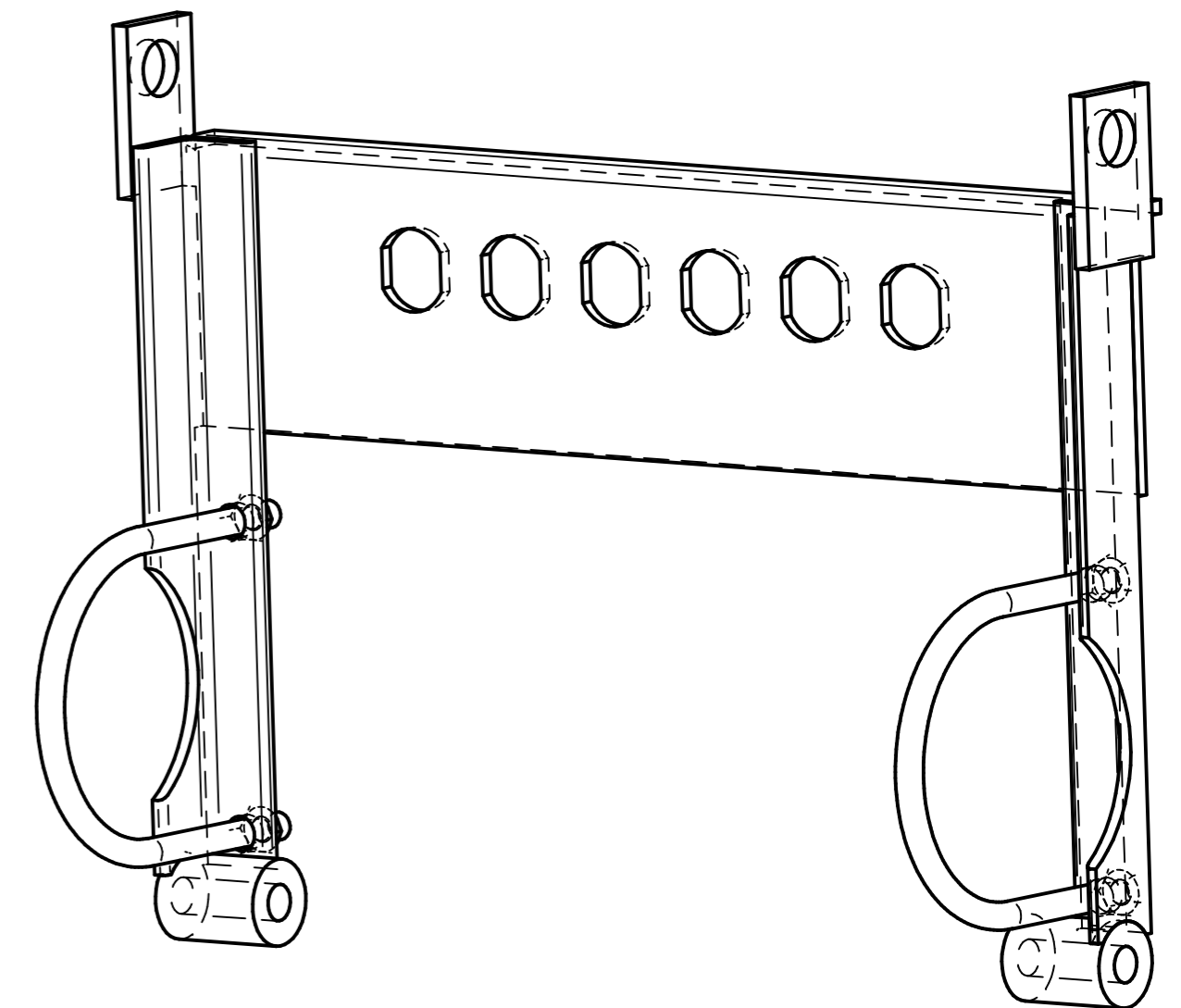
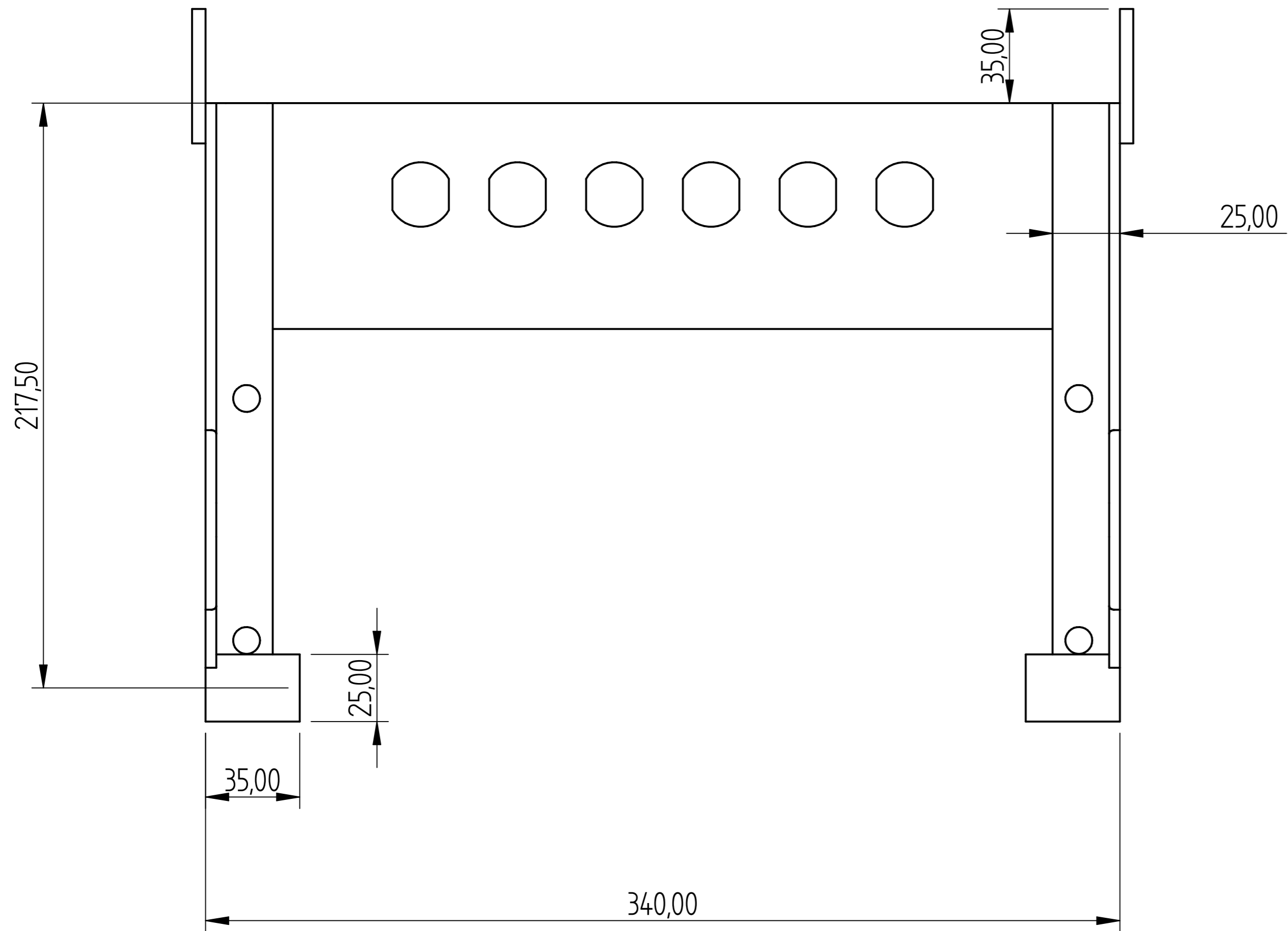

|  |      |          |                             |             |        |
|--|------|----------|-----------------------------|-------------|--------|
|  | NAME | DATE     | <b>AGRIGEL</b>              |             |        |
| DRAWN  | Dan  | 01/19/14 |                             |             |        |
| APPROVED   |      |          | TITLE<br>Squeeze Pump       |             |        |
| MATERIAL   |      |          |                             |             |        |
| TREATMENT  |      |          | SIZE<br>A4                  | DWG NO      | REV    |
| UNLESS OTHERWISE SPECIFIED<br>DIMENSIONS ARE IN MILLIMETERS<br>ANGLES ±0.1°<br>1st ANGLE |      |          | FILE NAME: Squeeze Pump.dft |             |        |
|  |      |          | 2 PL ±0.02                  | 3 PL ±0.005 | SCALE: |

| REVISION HISTORY |             |      |          |
|------------------|-------------|------|----------|
| REV              | DESCRIPTION | DATE | APPROVED |
|                  |             |      |          |

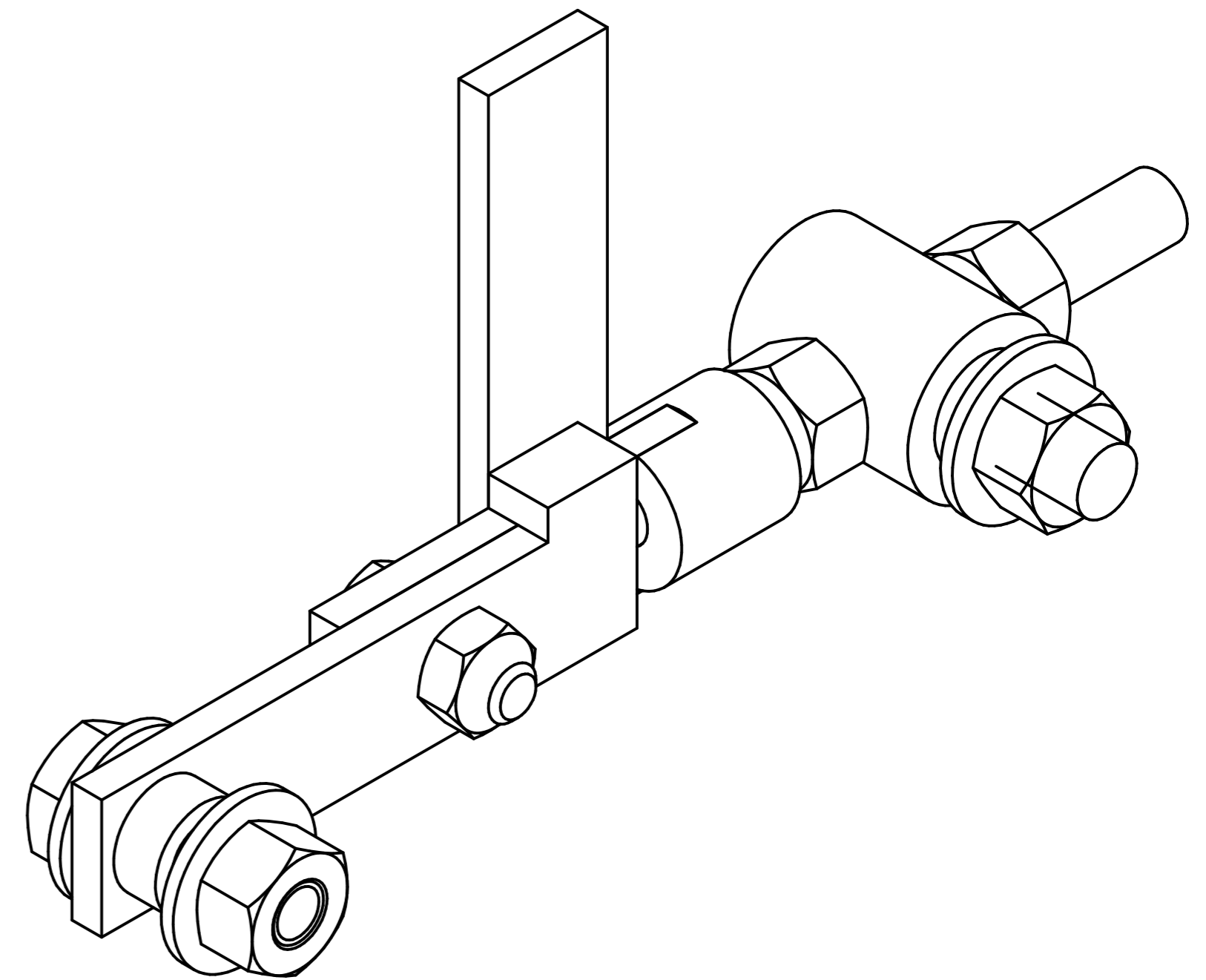
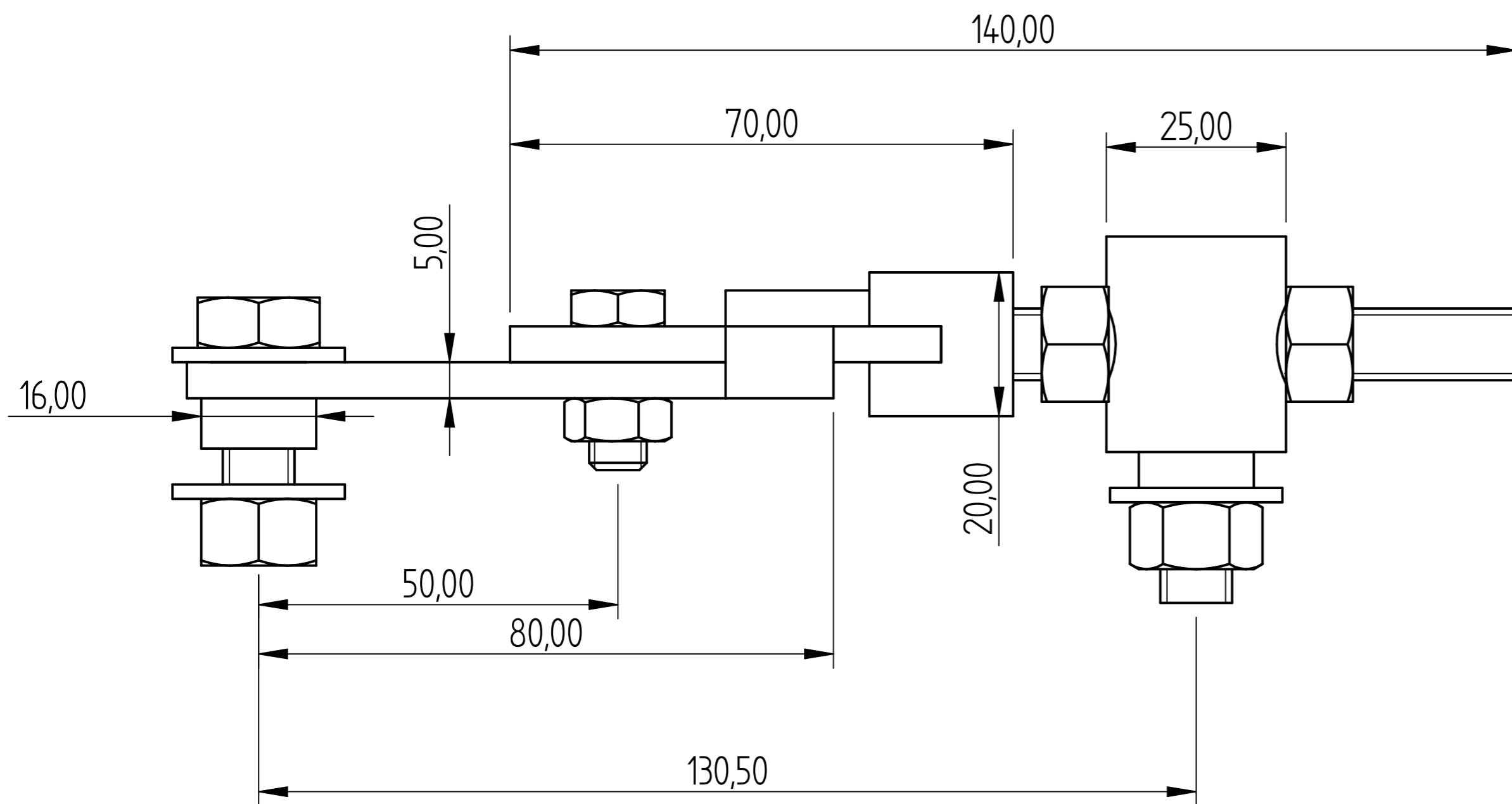
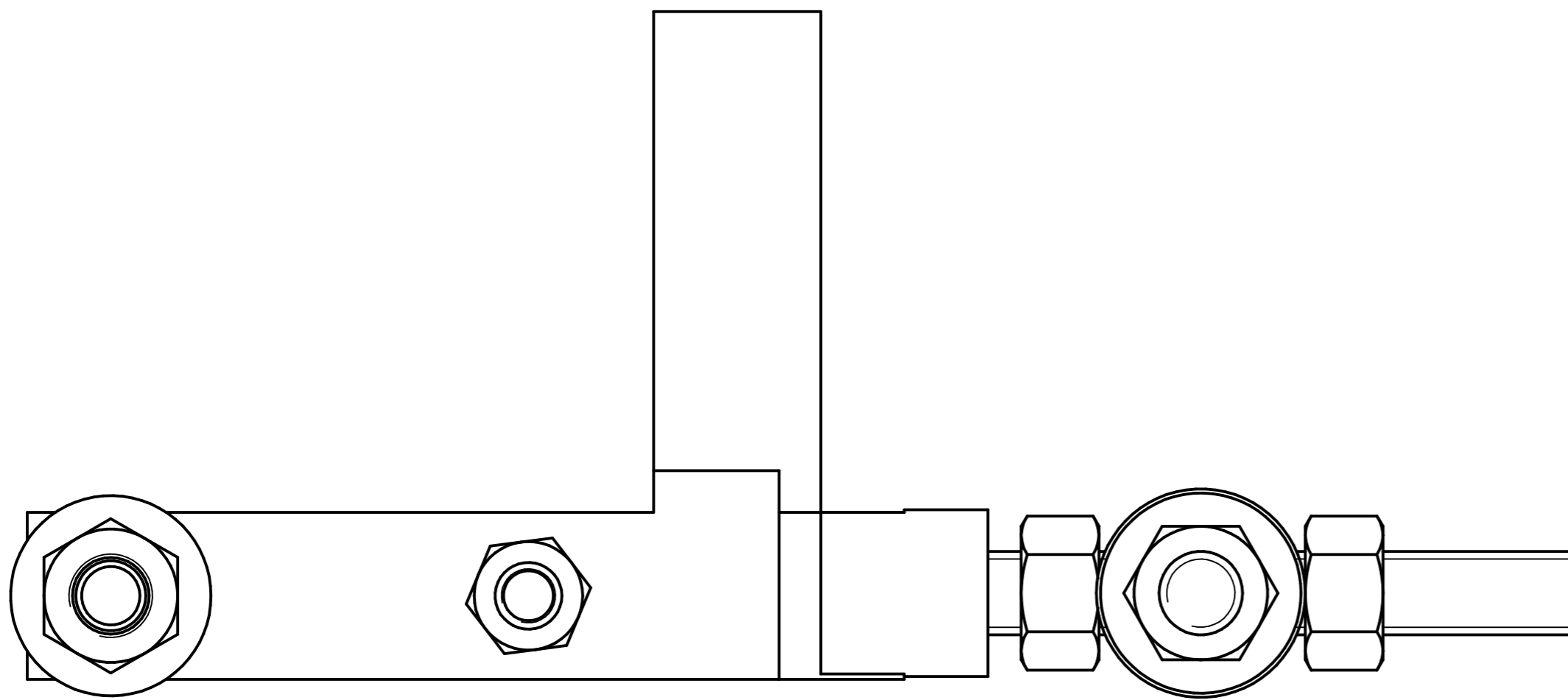

|   |      |          |                             |         |                |
|---|------|----------|-----------------------------|---------|----------------|
|   | NAME | DATE     | <b>AGRIGEL</b>              |         |                |
| DRAWN   | Dan  | 01/19/14 |                             |         |                |
| APPROVED  |      |          |                             |         |                |
| MATERIAL  |      |          |                             |         |                |
| TREATMENT   |      |          | TITLE                       |         |                |
|   |      |          | Squeeze Pump                |         |                |
| UNLESS OTHERWISE SPECIFIED<br>DIMENSIONS ARE IN MILLIMETERS |      |          | SIZE<br>A4                  | DWG NO  | REV            |
| 1 <sup>st</sup> ANGLE<br>ANGLES ±0.1°                       |      |          | FILE NAME: Squeeze Pump.dft |         |                |
| 2 PL ±0.02 3 PL ±0.005                                      |      |          | SCALE:                      | WEIGHT: | SHEET 13 OF 15 |

| REVISION HISTORY |             |      |          |
|------------------|-------------|------|----------|
| REV              | DESCRIPTION | DATE | APPROVED |
|                  |             |      |          |

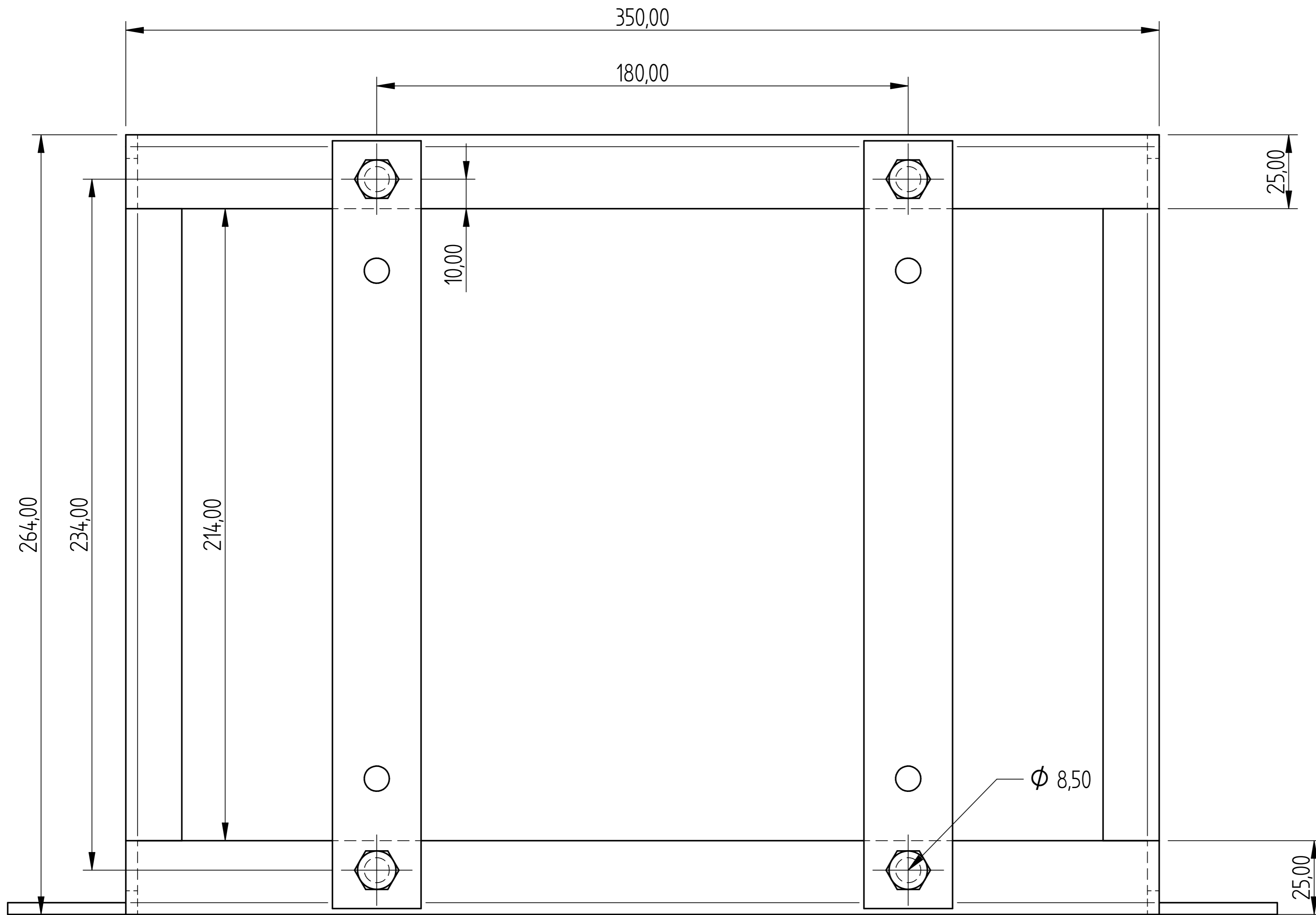

|   |      |          |                             |         |                |
|---|------|----------|-----------------------------|---------|----------------|
| DRAWN   | NAME | DATE     | <b>AGRIGEL</b>              |         |                |
| APPROVED  | Dan  | 01/19/14 |                             |         |                |
| MATERIAL  |      |          |                             |         |                |
| TREATMENT   |      |          |                             |         |                |
| UNLESS OTHERWISE SPECIFIED<br>DIMENSIONS ARE IN MILLIMETERS |      |          | SIZE<br>A4                  | DWG NO  | REV            |
| 1 <sup>st</sup> ANGLE<br>ANGLES $\pm 0,1^\circ$             |      |          | FILE NAME: Squeeze Pump.dft |         |                |
| 2 PL $\pm 0,02$ 3 PL $\pm 0,005$                            |      |          | SCALE:                      | WEIGHT: | SHEET 14 OF 15 |

| REVISION HISTORY |             |      |          |
|------------------|-------------|------|----------|
| REV              | DESCRIPTION | DATE | APPROVED |
|                  |             |      |          |

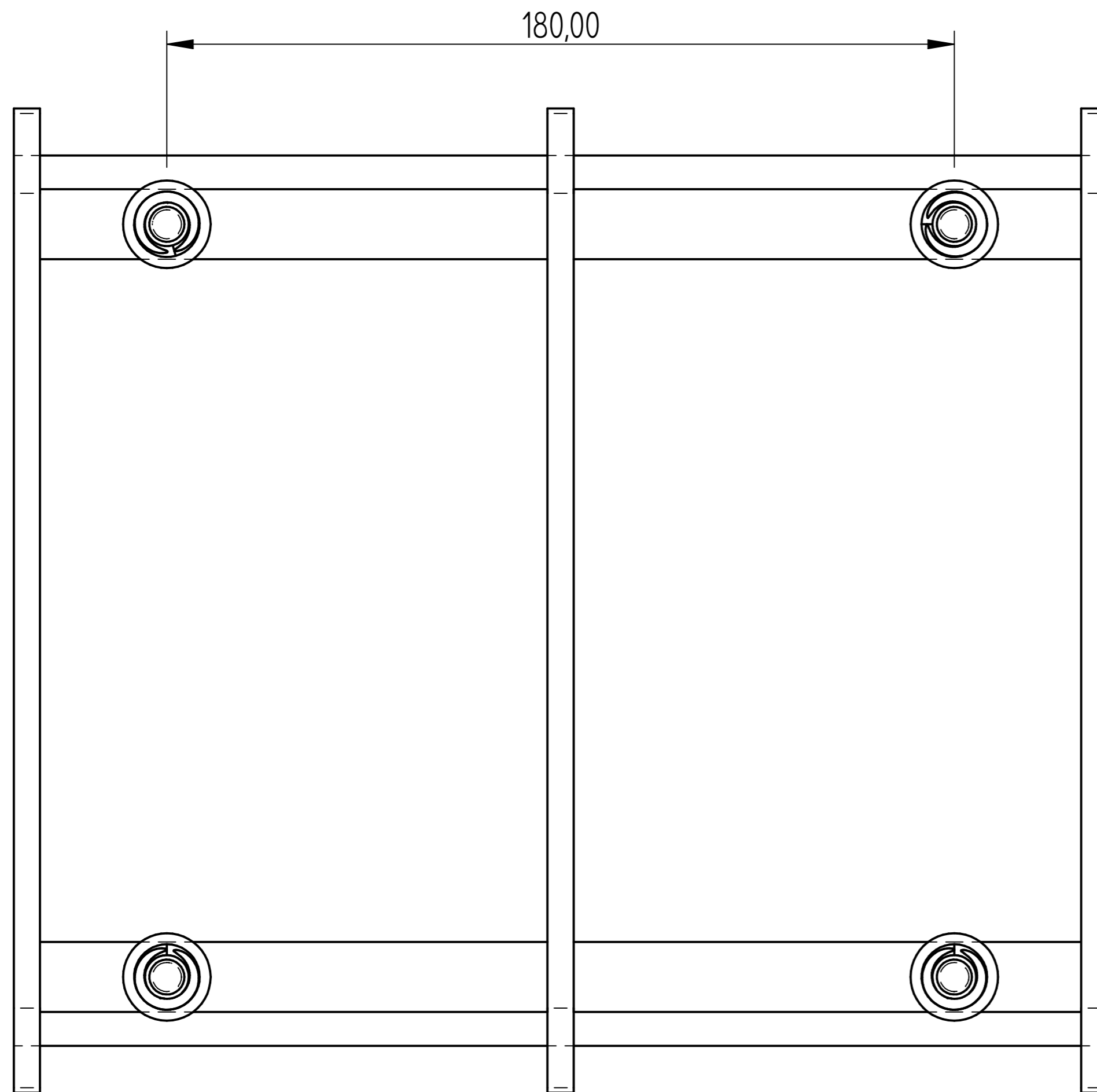

Back Plate

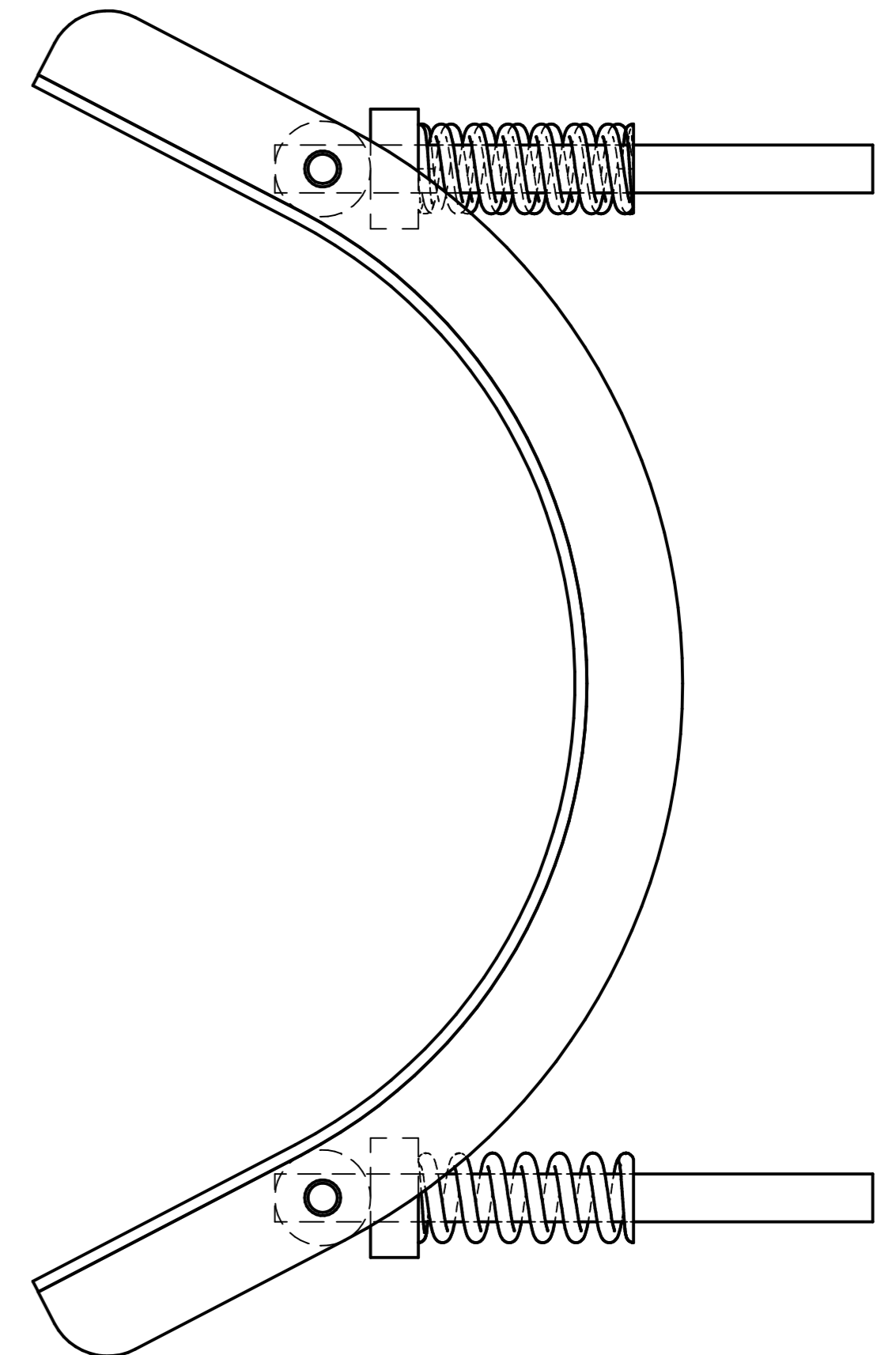

|   |      |          |                             |         |
|---|------|----------|-----------------------------|---------|
|   | NAME | DATE     | <b>AGRIGEL</b>              |         |
| DRAWN   | Dan  | 01/19/14 |                             |         |
| APPROVED  |      |          |                             |         |
| MATERIAL  |      |          |                             |         |
| TREATMENT   |      |          | TITLE                       |         |
|   |      |          | Squeeze Pump                |         |
| UNLESS OTHERWISE SPECIFIED<br>DIMENSIONS ARE IN MILLIMETERS |      |          | SIZE<br>A4                  | DWG NO  |
| 1st ANGLE<br>ANGLES ±0.1°                                   |      |          | FILE NAME: Squeeze Pump.dft |         |
| 2 PL ±0.02 3 PL ±0.005                                      |      |          | SCALE:                      | WEIGHT: |
|   |      |          | SHEET 15 OF 15              |         |