

REVISION HISTORY			
REV	DESCRIPTION	DATE	APPROVED

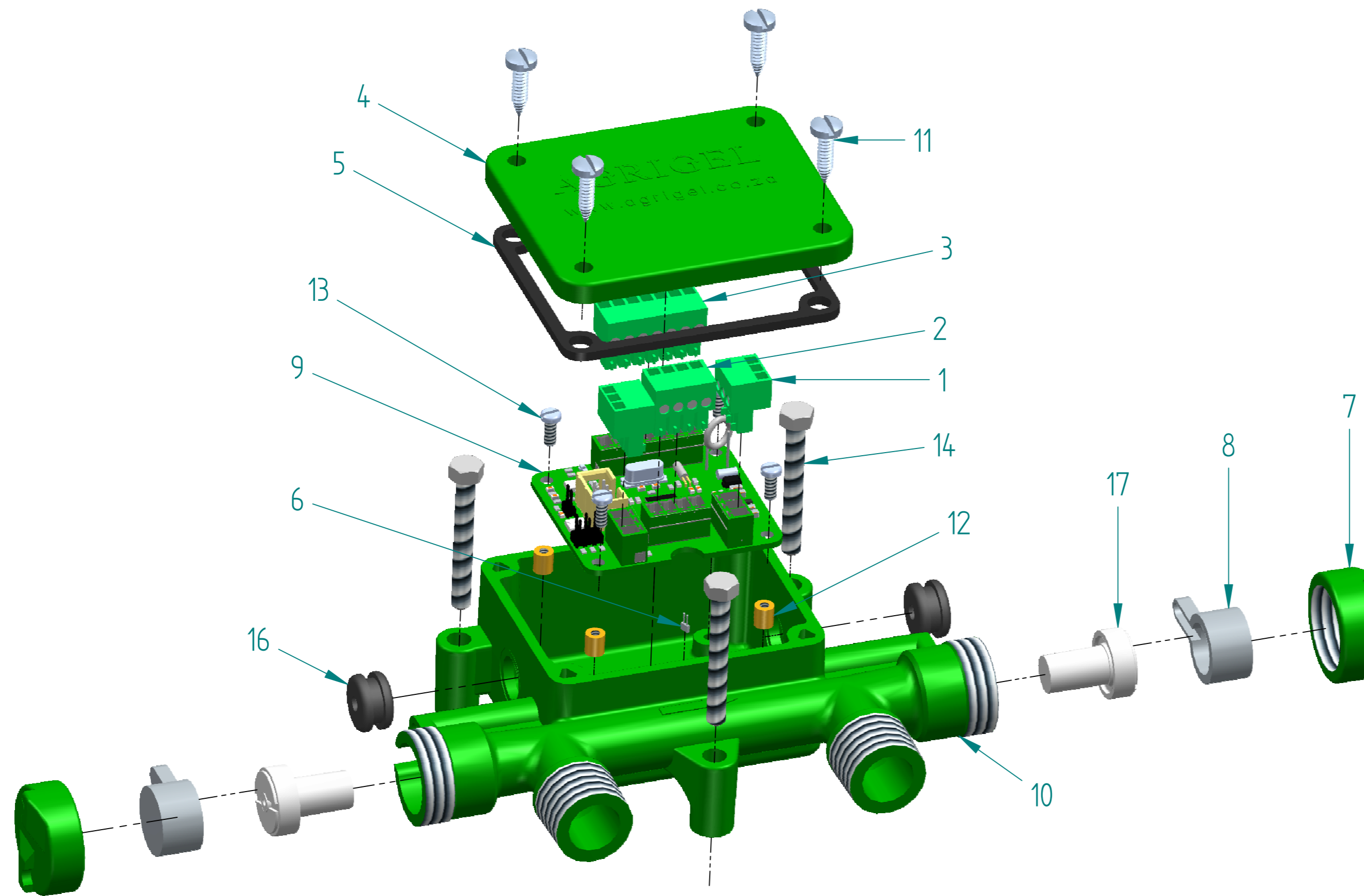

Item Number	Title	Document Number	Quantity	Item Number	Title	Document Number	Quantity
1	Connector 3 Pin		2	10	Ultrasonic Flow Meter Housing		1
2	Connector 4 Pin		1	11	Tapping Screw	Dia 4.2	4
3	Connector 7 Pin		1	12	Insert	M3 - 5.8	4
4	Lid		1	13	Screw CH	M3 - 8	4
5	Lid Seal		1	14	Bolt	M5 - 40	3
6	Temperature Sensor		1	15	O-Ring	P2-013	2
7	Transducer Cap		2	16	Grommet D4	PMFS-112	2
8	Transducer Spacer		2	17	Transducer	US_130531	2
9	UFO2-FM		1				

	NAME	DATE	AGRIGEL		
DRAWN	DG	05/29/14			
APPROVED			TITLE Flow Meter		
MATERIAL					
TREATMENT			UNLESS OTHERWISE SPECIFIED DIMENSIONS ARE IN MILLIMETERS ANGLES ±0.1° 1st ANGLE		
			SIZE A4	DWG NO	REV
			FILE NAME: Flow Meter.dft		
			SCALE:	WEIGHT:	SHEET 4 OF 4