



Bulletin HY11-5715-686/UK

## Operation Manual Series D\*FC / D\*1FC

D\*FC Design  $\geq 10$

D\*1FC Design  $\geq 10$

---

### Proportional Directional Control Valves



---

**Parker Hannifin**  
**Manufacturing Germany GmbH & Co. KG**  
Hydraulic Controls Division Europe  
Gutenbergstr. 38  
41564 Kaarst, Germany  
Tel.: (+49) 181 99 44 43 0  
E-mail: [valveshcd@parker.com](mailto:valveshcd@parker.com)  
Copyright © 2016, Parker Hannifin Corp.

**WARNING — USER RESPONSIBILITY**

**FAILURE OR IMPROPER SELECTION OR IMPROPER USE OF THE PRODUCTS DESCRIBED HEREIN OR RELATED ITEMS CAN CAUSE DEATH, PERSONAL INJURY AND PROPERTY DAMAGE.**

This document and other information from Parker-Hannifin Corporation, its subsidiaries and authorized distributors provide product or system options for further investigation by users having technical expertise.

The user, through its own analysis and testing, is solely responsible for making the final selection of the system and components and assuring that all performance, endurance, maintenance, safety and warning requirements of the application are met. The user must analyze all aspects of the application, follow applicable industry standards, and follow the information concerning the product in the current product catalog and in any other materials provided from Parker or its subsidiaries or authorized distributors.

To the extent that Parker or its subsidiaries or authorized distributors provide component or system options based upon data or specifications provided by the user, the user is responsible for determining that such data and specifications are suitable and sufficient for all applications and reasonably foreseeable uses of the components or systems.

**Offer of Sale**

Please contact your Parker representation for a detailed "Offer of Sale".

<b>Content</b>	<b>Page</b>
<b>1. Introduction</b>	<b>4</b>
Ordering code D*FC	4
Ordering code D*1FC	5
Name plate example	6
Characteristics of valve driver	6
Block diagram of integral electronics	7
Technical data	8
Signal flow diagram	9
Scope of supply	10
Important information	10
Information on the process of technical changes	10
Information on warranty and liability	10
CE mark	10
Personnel requirements	10
Compliance with other rules and instructions	10
<b>2. Safety</b>	<b>10</b>
Safety instructions	10
Use of the product	11
Limits of use	11
Contaminations	11
Remaining risks	11
<b>3. Use of the product</b>	<b>12</b>
Transport	12
Storage	12
Commissioning	12
Pressure fluids	13
Electrical connection	13
Electrical interfacing	15
Solenoid disable	19
ProPxD parametrizing software	20
Operation	23
Service/maintenance	23
Air bleeding of hydraulic system	23
Filter	23
Flushing	23
Decommissioning	23
Disposal	23
Trouble shooting	23
<b>4. Product information</b>	<b>24</b>
Other applicable standards/rules	24
Accessories / spare parts	25

Operation Manual

1. Introduction

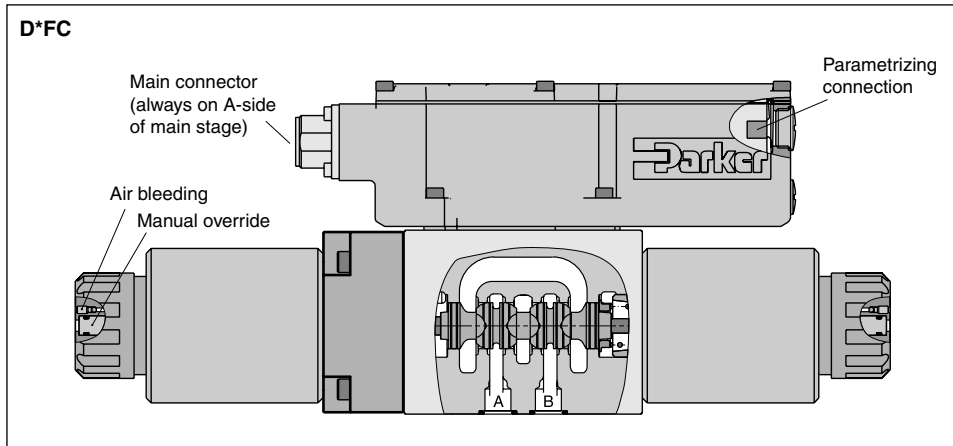

Ordering code D\*FC

<b>D</b>		<b>F</b>	<b>C</b>			<b>9</b>				<b>3</b>	
DC valve	Nominal size	Proportional control	High dynamics	Spool type (see catalogue)	Spool position <sup>1)</sup>	Drain port Y plugged <sup>4)</sup>	Seal	Command signal	Electrical options	Spool/body design	Design series (not required for ordering)

Code	Nominal size
1	NG06 / CETOP 03
3	NG10 / CETOP 05

Code	Spool position on power down
A <sup>2)</sup>	
B <sup>2)</sup>	
C <sup>3)</sup>	

Code	Seal
N	NBR
V	FPM

  

Code	Electronic options <sup>5)</sup>
0	6 + PE
1	6 + PE + enable + solenoid disable
3	6 + PE + solenoid disable
5	11 + PE
7	6 + PE with enable

Code	Signal	Function
B	0...±10 V	0...+10 V P -> A
E	0...±20 mA	0...+20 mA P -> A
K	0...±10 V	0...+10 V P -> B
S	4...20 mA	12...20 mA P -> A

<sup>1)</sup> On power down the spool moves in a defined position.  
This cannot be guaranteed in case of single flow path on the control edge A – T resp. B – T with pressure drops above 120 bar or contamination in the hydraulic fluid.  
<sup>2)</sup> Approx. 10 % opening, only zero lapped spools and underlap spools.  
<sup>3)</sup> Only for overlapped spools.  
<sup>4)</sup> Needs to be removed at tank pressure >35 bar.  
<sup>5)</sup> Please order connector separately.

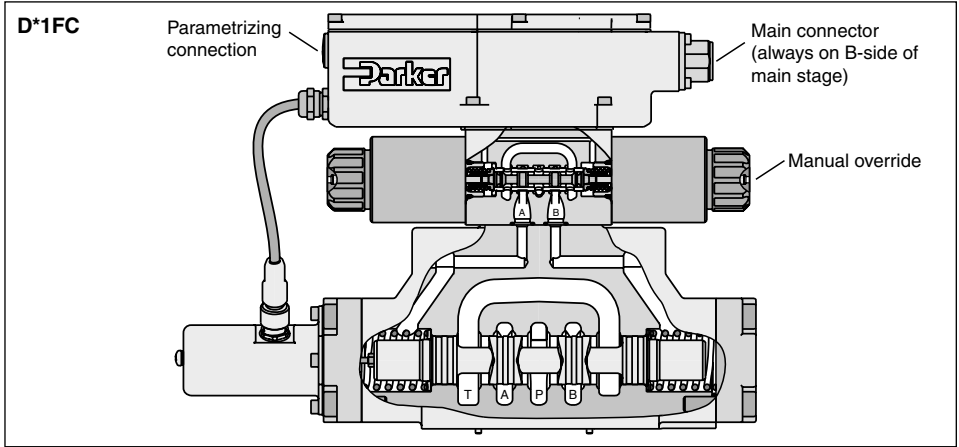

Ordering code D\*1FC

<b>D</b>		<b>1</b>	<b>F</b>	<b>C</b>			<b>C</b>								
<b>Direct control valve</b>		<b>NG06 pilot</b>	<b>Integrated electronics with position feedback</b>		<b>Flow</b> (see catalogue)		<b>Pilot connection</b> (see catalogue)		<b>Command signal</b>		<b>Valve options</b>				
	<b>Nominal size</b>	<b>Proportional control</b>		<b>Function</b> (see catalogue)	<b>Spool position on power down</b> (see catalogue)		<b>Seal</b>		<b>Electrical options <sup>2)</sup></b>		<b>Design series</b> (not required for ordering)				

Code	Nominal size
3	NG10 / CETOP 05
4	NG16 / CETOP 07
9 <sup>1)</sup>	NG25 / CETOP 08
11	NG32 / CETOP 10

Code	Seal
N	NBR
V	FPM

Code	Signal	Function
B	0...±10 V	0...+10 V P -> B
E	0...±20 mA	0...+20 mA P -> B
K	0...±10 V	0...+10 V P -> A
S	4...20 mA	12...20 mA P -> A

Code	Valve options
0	Standard für spool type B, E, R
8 <sup>2) 3)</sup>	Monitor switch
L	Hybrid valve 24 V normally closed for spool type Z

Code	Electronic options
0	6 + PE
1	6 + PE + enable + solenoid disable
3	6 + PE + solenoid disable
5	11 + PE
7	6 + PE with enable

  

<sup>1)</sup> With enlarged connections Ø 32 mm.

<sup>2)</sup> Not for D111FCZ\*.

<sup>3)</sup> Monitor switch for hybrid valves: code 8 includes options of code L (24 V normally closed).

## Name plate example

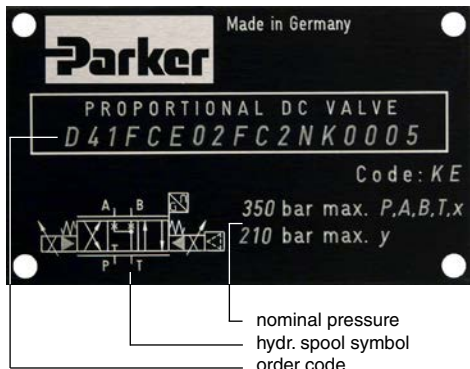

Parker D\*FC and D\*1FC proportional directional control valves have an integral electronics. Different flow sizes as well as command signal options are available to achieve an optimal adaption for different applications.

## Characteristics of valve driver

The described integral electronic driver combines all necessary functions for the optimal operation of the valve. The most important features are:

- digital circuit design
- high dynamic constant current solenoid control
- differential input stage with various command signal options
- four quadrant ramp function
- MIN adjustment for deadband compensation
- MAX adjustment to match the command signal span to the valve operating range





## Technical Data

General		
Design		Proportional directional control valve, direct operated (D*FC), pilot operated (D*1FC)
Actuation		Proportional solenoid
Size	D*FC D*1FC	NG06 (CETOP 03) / NG10 (CETOP 05) NG10 (CETOP 05) / NG16 (CETOP 07) / NG25 (CETOP 08) / NG32 (CETOP10)
Mounting interface		DIN 24340/ISO 4401/CETOP RP121/NFPA
Mounting position		unrestricted
Hysteresis	[%]	<0.1
Ambient temperature	[°C]	-20...+60
MTTF <sub>D</sub> value <sup>1)</sup>	[years]	D*FC: 150, D*1FC: 75
Weight	[kg]	D*FC NG06 = 3.4 / NG10 = 7.7 D*1FC: NG10 = 9.0 / NG16 = 12.5 / NG25 = 21.0 / NG32 = 68.5
Vibration strength	[G]	10 Sinus 5...2000 Hz acc. IEC 60068-2-6 30 Random noise 20...2000 Hz acc. IEC 60068-2-36 15 Shock acc. IEC 60068-2-27
Hydraulic		
Operating pressure	[bar]	D*FC: Ports P, A, B 350, port T max. 35; 210 (external drain); port Y max. 35 D*1FC: pilot oil internal P, A, B, X 350; T, Y 210 pilot oil external P, A, B, T, X 350; Y 210
Fluid		Hydraulic oil according to DIN 51524 ... 535, other on request
Fluid temperature	[°C]	-20...+60 (NBR: -25...+60)
Viscosity permitted	[cSt]/[mm <sup>2</sup> /s]	20...400
Viscosity recommended	[cSt]/[mm <sup>2</sup> /s]	30...80
Filtration		ISO 4406 (1999); 18/16/13
Electrical		
Duty ratio	[%]	100
Protection class		IP65 acc. EN 60529 (with correctly mounted plug-in connector)
Supply voltage Us	[VDC]	18...30, electric shut-off at < 17, ripple < 5 % eff., surge free
Current consumption max.	[A]	2.0 (D1FC, D*1FC), 3.5 (D3FC)
Pre-fusing	[A]	2.5 (D1FC, D*1FC), 4.0 (D3FC)
Command signal options	Uc [V] Ic [mA]	Codes B, K: +10...0...-10, ripple < 0.01 % eff., surge free, Ri = 100 kOhm Code S: 4...12...20, ripple < 0.01 % eff., surge free, Ri = <250 Ohm < 3.6 mA = enable off > 3.8 mA = enable on (acc. NAMUR NE43) Code E: +20...0...-20, ripple < 0.01 % eff., surge free, Ri = <250 Ohm
Differential input voltage max.	[V]	Code 0/1/3/7: 30 for terminal D and E against PE (terminal G)
	[V]	11 for terminal D and E against 0 V (terminal B)
	[V]	Code 5: 30 for terminal 4 and 5 against PE (terminal ↓)
	[V]	11 for terminal 4 and 5 against 0 V (terminal 2)
Adjustment ranges	Min [%] Max [%] Ramp [s]	0...50 50...100 0...32.5
Interface		RS232C, parametrizing connection 5pole
Enable signal (code 1/5/7)	[V]	5...30
Diagnostic signal	[V]	+10...0...-10 / +12.5 error detection, rated max. 5 mA
EMC		EN 61000-6-2, EN 61000-6-4
Central connection		Code 0/1/3/7: 6+PE acc. EN 175201-804 Code 5: 11+PE acc. EN 175201-804
Cable specification	[mm <sup>2</sup> ]	Code 0/1/3/7: 7 x 1.0 (AWG16) overall braid shield
	[mm <sup>2</sup> ]	Code 5: 8 x 1.0 (AWG20) overall braid shield
Cable length max.	[m]	50
Solenoid disable:		
Electrical connection		Code 1/3: Female M12x1; 5p acc. to IEC-61076-2-101
Wiring min.	[mm <sup>2</sup> ]	0.34 (AWG22)
Cable length max.	[m]	50

With electrical connections the protective conductor (PE ↓) must be connected according to the relevant regulations.

<sup>1)</sup> If valves with onboard electronics are used in safety-related parts of control systems, in case the safety function is requested, the valve electronics voltage supply is to be switched off by a suitable switching element with sufficient reliability.

Signal flow diagram

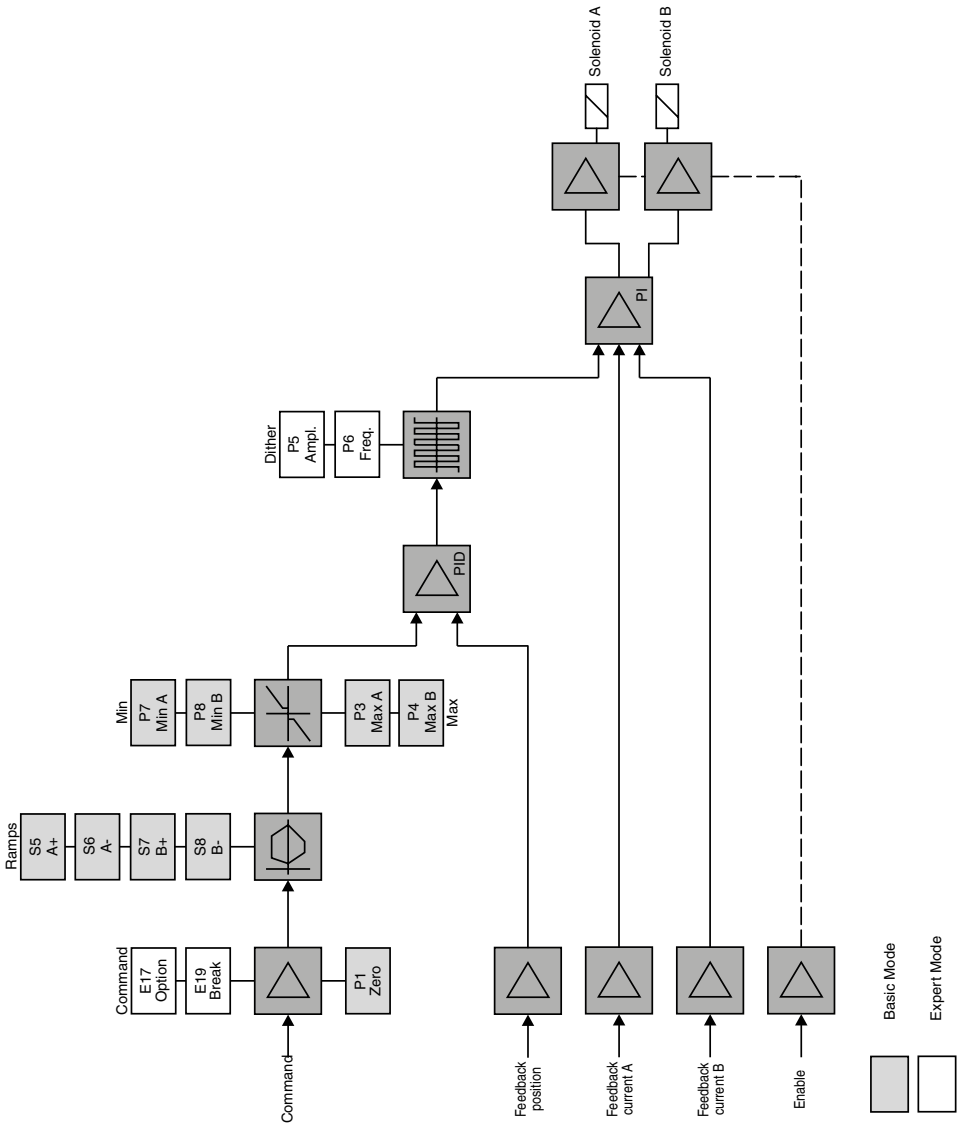

## Scope of supply

Please check immediately after receiving the valve, if the content is matching with the specified scope of supply. The delivery includes:

- valve
- operation manual

The central connector assembly has to be ordered separately and is not included in the delivery.

 Please check the delivery immediately after receiving the shipment for apparent damages due to shipping. Report shipment losses at once to the carrier, the insurance company and the supplier!

## Intended usage

This operation manual is valid for proportional directional control valves D\*FC/D\*1FC series. Any different or beyond it usage is deemed to be as not intended. The manufacturer is not liable for warranty claims resulting from this.

## Information on the process of technical changes

We reserve the right to make technical changes as a result of further development of the product described in these operating instructions. Figures and drawings in these instructions are simplified depictions. As a result of developments, improvements and changes to the product, it is possible that the figures are not fully consistent with the valve in operation. The technical details and dimensions are non-binding. They may not form the basis of any claims. Copyright reserved.

## Information on warranty and liability

The manufacturer does not assume liability for damage due to the following failures:

- incorrect mounting / installation
- improper handling
- lack of maintenance
- operation outside the specification

 Do not disassemble the valve! In case of suspicion for a defect please return it to Parker.

## CE mark

The CE mark appears on the main nameplate. If the product is installed as part of a larger machine, this larger machine is in turn subject to EU directives and must therefore obtain a general CE mark for the machine as a whole. The machine must not enter circulation in the EU until this is done. The legal requirements corresponding to the CE mark can be found in section "Other applicable standards / rules".

## Personnel requirements

The product may only be used, installed, removed, operated and maintained by specialist personnel. For the purposes of these instructions, a specialist is defined as someone who, on the basis of their education, expertise and professional experience, is able to correctly evaluate and carry out the tasks and duties assigned to him/her, and identify and correct potential hazards. Skilled, semi-skilled or trained personnel may not use this product under their own responsibility unless they have the required specialist knowledge. Otherwise, they may only use the product under the constant supervision of a specialist person.

## Compliance with other rules and instructions

Carry out transport and installation/repair activities only in accordance with the valid and applicable safety and accident prevention regulations issued by the trade associations.

The valve contains hydraulic oil. The normal local environmental protection requirements must therefore be met when handling the product. The particular circumstances of each place of installation mean that instructions must be followed in order to install and use the product safely.

## 2. Safety

### Safety instructions

Please read the operation manual before installation, startup, service, repair or stocking! Paying no attention may result in damaging the valve or incorporated system parts.

## Use of the product

The product must only be used if it is perfect in working order. Problems that may impair safety must be corrected.

 This product is a safety component that may only be repaired by the manufacturer if it malfunctions. If the safety components are repaired by the user, the manufacturer's warranty is invalidated because the manufacturer is demonstrably unable to ensure that the product is used as specified.

## Limits of use

The product may only be operated within the specified limits of use. The relevant details can be found in „Technical data“.

 Ambient conditions must be observed. Unauthorized temperatures, shocks, the effects of aggressive chemicals, radiation, unauthorized electromagnetic emissions may result in disruptions and failures. Observe the limits of operation set out in „Technical data“.

## Contaminations

Function and service life of the valve are heavily dependent on the purity and quality of the pressure fluid and depend upon the operating conditions of the hydraulic components. Appropriate filters must be used and regular inspections of the medium must be carried out to prevent contamination of the pressure fluid. Permitted level of contamination is set out in the „Technical data“.

 Be aware of three important sources of contamination:

- Contaminations entering during installation
- Contaminations occurring during operation
- Dirt entering from the surroundings

## Remaining risks

### Allergic reactions

Hydraulic oil can cause allergic reactions on susceptible skin. This can be prevented by taking the precautions that are usual when handling mineral oil products and by using personal protective equipment.

## Leaking plugs

 Leaking plugs can cause a malfunction. That is why the plugs must be checked for leaks at the regular maintenance interval. Leaking plugs may constitute a safety hazard, so the valve must be returned to Parker for repair.

## Lightning

 If electronic components are exposed to electromagnetic fields as a result of lightning, they must be checked to ensure they are still working perfectly. If there is a malfunction, the product must be returned to Parker.

## Temperature

The surface of our product may heat up in use.

 The service temperatures may exceed the temperature threshold for burn injury, 70 °C. Above this threshold, even brief contact with the surface may result in a burn. The only way to consistently prevent burn injuries is to use personal protective equipment and to remain safety-conscious at all times.

 If integrated electronics are exposed to a temperature above 80 °C, they may malfunction.

## Power failure

 In a power failure the valve piston returns to the spring centred starting position. You must check whether this creates potential hazards when the system/machine is used.

## Hydraulic

D\*FC/D\*1FC valves are tested and approved with an even flow. If the flow becomes asymmetrical, the safety function of the valve may be compromised. You should therefore carry out tests before commissioning to verify that the valve is in good working order.

If the valve piston has been under pressure and stationary in the end position for an extended period, oil particles may cause the piston to seize. For this reason the valve should be actuated regularly.

## 3. Use of the product

### Transport

Depending on size, lifting equipment or transport aids are needed. Our product leaves the factory in perfect working order, and appropriate packaging is used to protect it from damage.

 The condition of the product on arrival is no longer under our control, so please check for transport damage/defects immediately after arrival. Document the transport damage and immediately notify the carrier, the insurance company and the manufacturer. Do not dispose of the packaging unless there is no transport damage and the entire package contents have been removed from the packaging. If the product has been damaged during transport, it must be exchanged for a new one.

When transporting the product within your premises, make sure it is kept in a safe position and protected in its original packaging until it is ready to use. Note also the information in sections "Warranty and liability", "Basic information on using the manual", "Other applicable standards/rules", "Personnel requirements", "Remaining risks".

### Storage

If the product needs to be temporarily stored, it must be protected from dirt, the weather, and damage. Each valve is tested with hydraulic oil in the factory, so that the internal components are protected from corrosion. However, this protection can only be guaranteed under the following conditions:

Storage time	Conditions
12 months	Stable air humidity 60 % and stable temperature < 25 °C
6 months	Fluctuating air humidity and fluctuating temperature < 35 °C

The product is delivered with adequate corrosion protection, provided our recommendations for the ambient conditions are followed.

 Storage outside or in maritime or tropical climates without appropriate packaging leads to corrosion and may make the product unusable.

 Make sure the product is stored so that no injuries can be caused by tipping or falling. In particular, make sure that the safety rules for high-bay racking are followed.

### Commissioning

After installing our product in a system/machine, make sure that the requirements of the Machinery Directive are met if applicable. Access should be provided to the hydraulic diagram, the equipment list and the logic diagram for the system/machine.

 The product must be checked for damage and missing parts (e.g. seals) before installation, especially in the area of the sealing surfaces and the safety devices. If the safety devices or sealing surfaces are damaged or are missing individual parts with relevance to the product's function, the product may not be used.

Remove all transport securing devices, protective covers and packaging.

 Check for foreign objects in the open hydraulic passages. Contaminations may impair operational reliability and shorten the service life.

 Make sure that the hydraulic system/machine is unpressurised before the product is installed.

 Before commissioning, the specialist personnel must verify that the entire hydraulic system has been installed correctly. Commissioning must be carried out with care, taking account of all safety regulations.

If necessary, erect warning signs to prevent unintended operation. Note also the information in sections "Warranty and liability", "Basic information on using the manual", "Other applicable standards/rules", "Personnel requirements", "Remaining risks".

Compare valve type (located on the name plate) with part list resp. circuit diagram.

- The valve may be mounted fix or movable in any direction.
- Verify the mounting surface for the valve. Un-evenness of 0.01 mm /100 mm, surface finish of 6.3 µm are tolerable values.

 Keep clean valve mounting surface and work environment!

- Remove protection plate from the valve mounting surface
- Check the proper position of the valve ports and the O-rings.

Mounting bolts:

- D1FC: 4 pcs. M5x30
- D3FC: 4 pcs. M6x40
- D31FC: 4 pcs. M6x40
- D41FC: 2 pcs. M6x55, 4 pcs. M10x60
- D91FC: 6 pcs. M12x75,
- D111FC: 6 pcs. M20x90

Use property class 12.9, ISO 4762

Tighten the bolts crisscross with the following torque values:

D1FC: 7.6 Nm	D31FC: 13.2 Nm
D3FC: 13.2 Nm	D41FC: 13.2/63 Nm
	D91FC: 108 Nm
	D111FC: 517 Nm

 Insufficient condition of the valve mounting surface might create malfunction! Incorrect mounting resp. bolt torque may result in abrupt leakage of hydraulic fluid on the valve ports.

### Pressure fluids

The following rules apply for the operation with various pressure fluids: The above information serves for orientation and does not substitute user tests among the particular operating conditions. Particularly no liability for media compatibility may be derived out of it.

Mineral oil: usable without restrictions

For operation with the following pressure fluids please consult Parker:

HFA	Oil-in-water emulsion
HFB	Water-in-oil emulsion
HFC	Aqueous solution (glycols)
HFD	Unhydrous fluids (Phosphor-Ester)

For detailed information concerning pressure fluids note VDMA-document 24317 as well as DIN 51524 & 51502.

Special gaskets may be available depending on the utilized fluid. In case of insecurity please consult Parker.

### Electrical connection

The electrical connection of the valve takes place by one common cable, which is coupled to the integrated electronic driver by a central connector assembly.

The connection Codes 0, 1, 3 and 7 requires a 6 + PE female connector EN 175201-804.

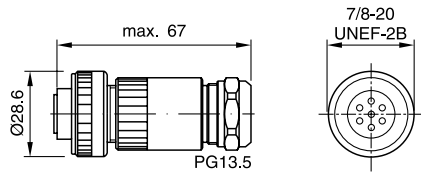

 The female connector has to be ordered separately under article nr. 5004072.

 A female connector with metal housing is required! Plastic made models may create function problems due to insufficient EMC-characteristics.

The connecting cable has to comply to the following specification:

- Cable type control cable, flexible, 7 conductors, overall braid shield
- Cross section min. AWG16/1.0 mm<sup>2</sup>
- Outer dimension 8...12 mm
- Cable length max. 50 m

 For cable lengths > 50 m consult Parker.

The connection cable is coupled to the female connector by solder joints.

Skinning lengths for the connecting cable:



 Do not disconnect cable socket under tension!

The connection Code 5 requires a 11 + PE female connector EN 175201-804.

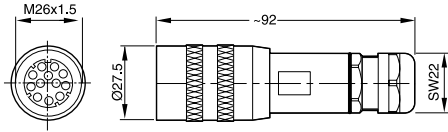

➔ The female connector has to be ordered separately under article nr. 5004711.

⚠ A female connector with metal housing is required! Plastic made models may create function problems due to insufficient EMC-characteristics.

The connecting cable has to comply to the following specification:

Cable type	control cable, flexible, 8 conductors, overall braid shield
Cross section	min. AWG16 / 1.0 mm <sup>2</sup>
Outer dimension	12...15 mm
Cable length	max. 50 m

➔ For cable lengths > 50 m consult Parker.

The connection cable is coupled to the female connector by crimp contacts.

Stripping lengths for the connecting cable:



➔ For the workmanlike termination of the crimp contacts the tool # 932 507-001 – supplier: Hirschmann – is required.

⚠ Do not disconnect cable socket under tension!

The shielding has to be assembled according the outline below:

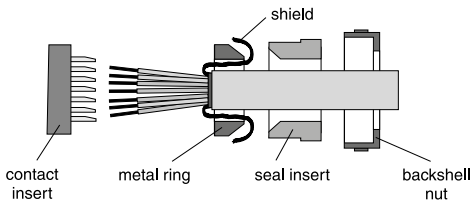

The backshell nut of the cable gland has to be tightened with a suitable tool. The target value for the tightening torque is 4 Nm. Tighten the cap nut with a torque of approx. 5 Nm after attaching the female connector on the socket outlet.

⚠ Incomplete tightening of backshell nut resp. cap nut may result in automatic release of the connection as well as degradation of the water tightness.

Follow the “instructions for use“ for installation of female connectors made by other kind of brands!

⚠ The cable connection to the female connector has to take place by qualified personnel! A short between individual conductors resp. to the connector housing, bad soldering as well as improper shield connection may result in malfunction and breakdown of the valve.

⚠ The mounting surface of the valve has to be carefully tied to the earth grounded machine frame. The earth ground wire from the valve connecting cable as well as the cable shield have to be tied to the protective earth terminal within the control unit. It is necessary to use a low ohmic potential connection between control unit and machine frame to prevent earth loops (cross section AWG6 > 10 mm<sup>2</sup>).

Electrical interfacing

Supply voltage:

The supply voltage for the valve has to cover the range of 18...30 V. The residual ripple may not exceed 5 % eff.

**!** The applied power supply must comply to the relevant regulations (DIN EN 61558) and must carry a CE-mark. The operating voltage for the valve must be free of inductive surges. Do not exceed the max. value of 30 V. Non-observance of this rule may result in permanent damaging of the valve.

**!** The increased inrush current of the valve should be considered when selecting the power supply. A stabilized power supply with overcurrent limiting feature should not be used. Due to the inrush current of the valve the current limit circuit may respond prematurely and create problems during energizing of the supply voltage.

**!** The operation of the valve is blocked if the supply voltage polarity is interchanged.

**!** Each valve requires a separate pre-fuse (rating: s. techn. data). Non-observance of this instruction may create irreparable damage of valve resp. incorporated system parts.

Wiring diagram of supply voltage

Code 0/1/3/7 (6 + PE)

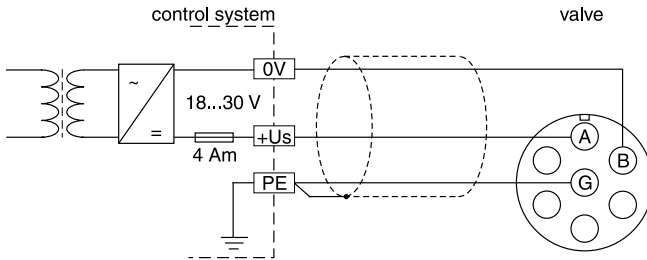

Code 5 (11 + PE)

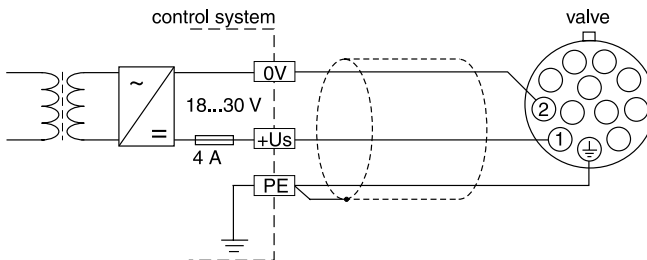

## Enable input (only for Code 5 / 11+PE and Code 1/7 / 6 + PE)

A signal voltage enables the actuator drive of the valve. Continuous operation of the valve requires a permanent voltage 5...30 V (i.e. the supply voltage). In case of disabling the signal the valve will reach its hydraulic default (power down) position in no time independently from the command signal value. At the same time the position controller output will be clamped. In case of restarting the enable signal, the valve spool takes its position always out of the power down. Preferable the enable signal should be switched on together with the hydraulic pressure

supply. This forces the actuator drive into drop out condition when the hydraulic system is switched off, and it avoids needless heating of the actuator.



The enable function represents no safety arrangement against unwanted valve operation in terms of rules for accident prevention! To block the valve function under all conditions, more advanced steps are necessary, i.e. the installation of additional safety check valves.

### Wiring diagram of enable input Code 5 (11 + PE)

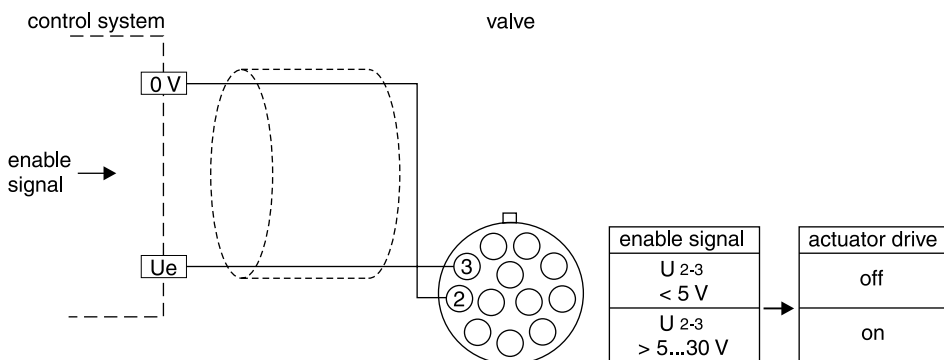

### Wiring diagram of enable input code 1/7 (6 + PE)

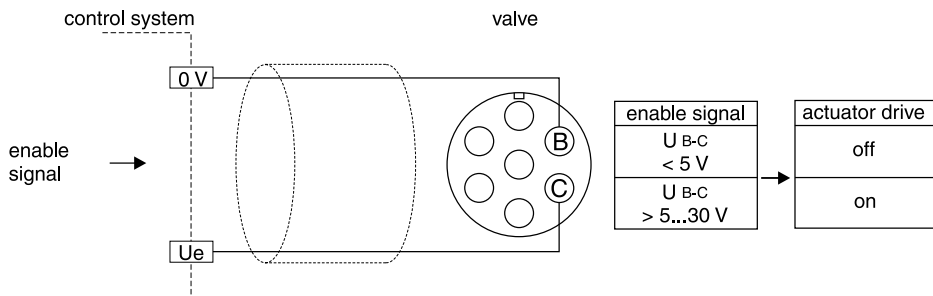



## Command signal input

The command signal for the valve will be connected to the pins D and E of the difference signal input of the electronic driver. The spool stroke behaves proportional to the command signal amplitude. Different versions of command signal processing are available, depending on the valve type. These are described below:

For the function description is assumed as signal reference (0V):

Code 0/3: pin E, Code 1/7: pin E, Code 5: pin 5

 Details are shown from the technical specifications.

 The command input signal needs to be filtered as well as free of inductive surges and modulations. Due to the sensitivity of the valve a high signal quality is recommended, this will prevent malfunction.

 Incorrect signal amplitude levels may disturb the functionality and can damage the valve.

 The option 4...20 mA uses the "0 mA" condition as breakdown-information. This means the presence of an evaluable failure information if the input signal line is interrupted. In this case the actuator drive will be switched off. The drive will switch on when the input signal reaches a value of 3.8 mA, it switches off when the command falls below 3.6 mA. This determination follows the NAMUR-specification NE43. NAMUR is an association of users of process control technology.

Operation Manual

Wiring diagram of voltage command input +10...0...-10 V Code 0/1/3/7 (6 + PE)

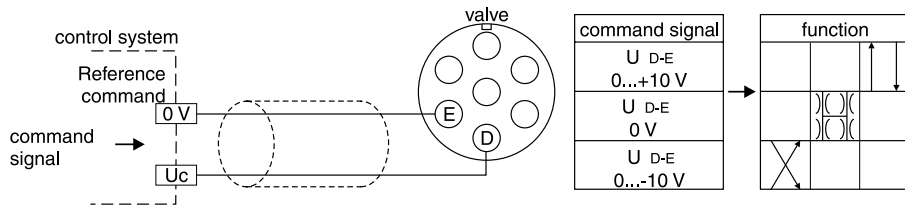

Wiring diagram of current command input 4...12...20 mA Code 0/1/3/7 (6 + PE)

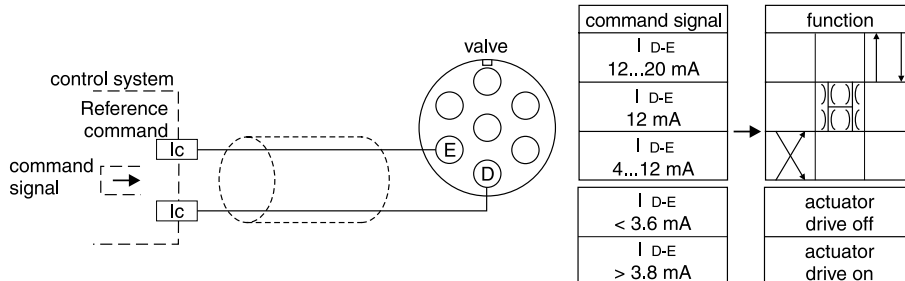

Wiring diagram of voltage command input +10...0...-10 V Code 5 (11 + PE)

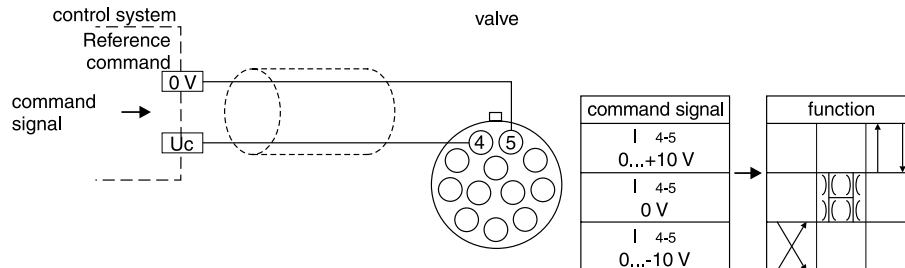

Wiring diagram of current command input 4...12...20 mA Code 5 (11 + PE)

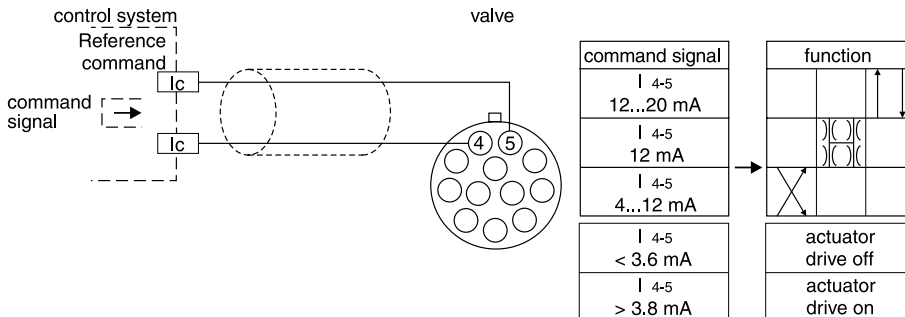

**Diagnostics output**

A diagnostics signal is available. Its voltage represents the operating condition of the valve.



The output may drive a load of max. 5 mA. Exceeding of this limit leads to malfunction.

The following information is available:

- position of valve spool (+10...0...-10 V means +100...0...-100 % spool stroke).

**Wiring diagram of diagnostics output Code 0/1/3/7 (6 + PE)**

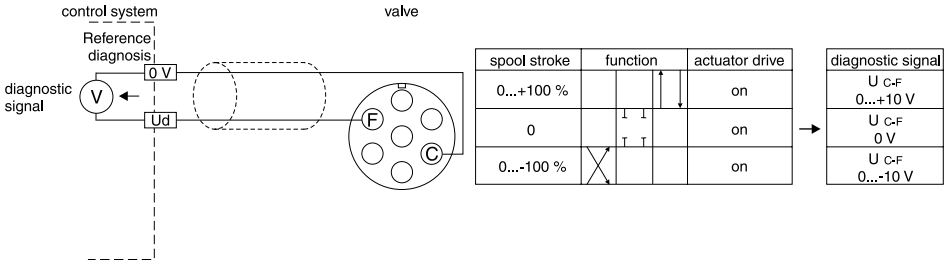

**Wiring diagram of diagnostics output Code 5 (11 + PE)**

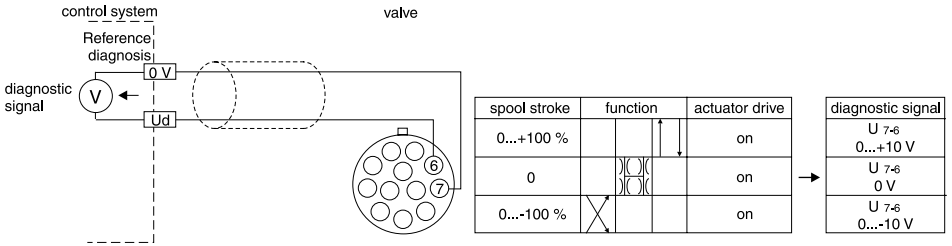

**Solenoid disable**

Pin assignment, valve side, M12 A coding

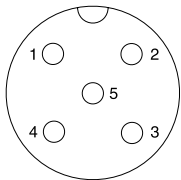

(connection side view)

Solenoid B	Pin 1	U <sub>B</sub>
	Pin 2	0 V
Solenoid A	Pin 3	U <sub>B</sub>
	Pin 4	0 V

## ProPxD parametrizing software

The ProPxD software allows quick and easy setting of the digital valve electronics. Individual parameters as well as complete settings can be viewed, changed and saved via the comfortable user interface. Parameter sets saved in the non-volatile memory can be loaded to other valves of the same type or printed out for documentation purposes.

See [www.parker.com/euro\\_hcd](http://www.parker.com/euro_hcd) section "Support" or directly at [www.parker.com/propxd](http://www.parker.com/propxd) for free software download.

## Parametrizing connection

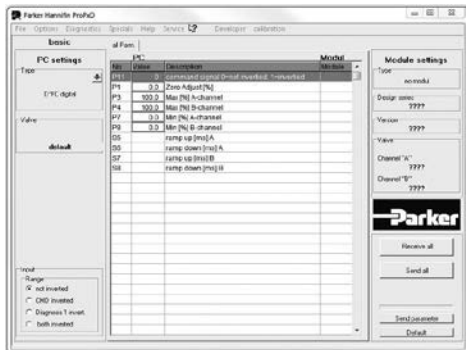

## Hardware requirements

- PC with operating system from Windows® XP upwards
- Interface RS232C
- display resolution min. 800 x 600
- connection cable between PC and electronic module
- storage requirement approx. 40 MB

☞ If your PC has no serial interface according to RS232 standard, you require in addition an USB-RS232 adapter for connection to the USB interface.

## Cable specification

The cable which is required for the connection of the valve electronic to a PC may be ordered under code 40982923. The cable has to be inserted between an unused serial port of the PC and the 5pole socket connector of the valve electronic (parametrizing connector).

⚠ Attention! The valve electronic provides no USB interface, but can only be parametrized via an RS232 - connection. Therefore the usage of USB standard cables is permitted and may result in damaging of valve resp. PC.

## Parametrizing cable

Ordering code: 40982923

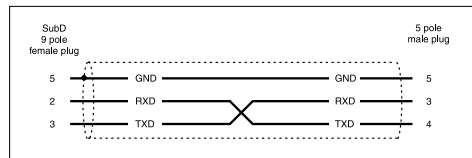
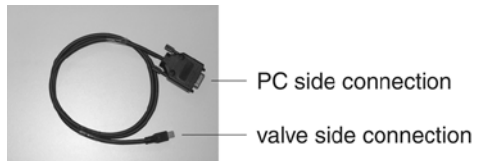

## Parametering interface

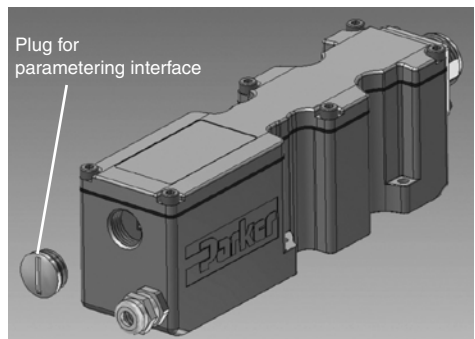

⚠ The cover plug has to be re-installed after completion of the parametrizing work.

## Program installation

Please check before installation if the above hardware requirements are met. If your PC has already stored an older version of the “ProPxD” program, it has to be deinstalled by using the Windows® system control feature.

Program installation sequence:

- terminate the execution of other programs
- execute the file “setup.exe”
- follow the instructions on the screen

Answer the question, if an older version should be overwritten, with “ok”. During the installation you may change destination drive resp. installation path, if needed. Please answer “ok” if at the end of the installation the program reports any system information. After successful installation the desktop display shows the ProPxD icon for starting the program.

## Software operating

Brief instruction for first startup:

- Connect the valve electronic to the supply voltage.
- Connect the valve electronic to a PC via the parametrizing cable.
- Start the operating program.
- After displaying the program resp. data base version a program window opens and the connected valve will be automatically identified (possibly a manual identification via the button “Receive all” is necessary).
- Select the desired version via the menu “Options/Optionen” with the menu item “Language/Sprache”.
- The valve specific default parameters are already available within the parameter table.
- Individual parameters may be selected via mouse or the arrow buttons at the center of the program screen.
- Parameter changes are possible via mouse or the arrow buttons on the bottom left within the program screen, also the parameter values may be edited via the keyboard.
- Modified parameters will be stored via the “Enter” key or via the button “Update list”.
- Parameters have to be nonvolatile stored on the valve via the button “save parameter”.

- The chosen parameters may be optionally stored on the PC via the “File”-menu with the menu item “Save as”, data retrieving is always possible via the function “Load file”

## Extended functions

The user software is shared into 2 parameter ranges:

- basic mode
- expert mode

For normal startup the basic mode is absolutely sufficient. It permits the setting of all application specific parameters to match the valve function with the task setting. In case of special applications the valve parameters may be adapted via the expert mode. The operating mode may be selected from the “Options”- menu and remains after terminating and re-start of the program.



Changing of expert parameters is only permitted for qualified personnel. Incorrect settings may lead to malfunction! In case of parameter changes shut the drive down!

The expert mode is protected by a pass word request. The name is “parker”. The button “Send parameter” appears in the “Expert”-operating mode. This button transmits only the setting of one single parameter to the connected valve. Thus a quick tuning of single parameters is permitted during the setup.



A horizontal bar graph readout between the communication buttons shows the data transfer state.



Because the ProPxD program has also offline (i.e. without connection to the valve) functionality, a manual pre-selection of the parameters is possible. After selection of the valve type via the menu “Options” the parameters may be set and stored for later transmission. Note the design series while selection of the valve!

The “File” menu provides the functions “Printer setup”, “Print preview” and “Print”. The print preview includes the option for parameter set storage as text file (format.txt) prior to further processing. The “Options” menu provides also the selection of the RS232C interface port via the menu item “Port”. Via the menu item “Load file” previously stored parameter sets may be loaded.

Individual description of additional expert parameters

Parameter	Function	Unit	Parameter Range	Default Setting
E17 type of command signal device	Adjustment of the command signal option. To match the command signal input to the input signal mode.	-	1, 2, 3, 5	depending on valve
E19 cable break detection command	Adjustment of the operating mode for the command cable break detection. To turn on resp. off of the cable break detection of the command signal at a selected command signal option of 4...20 mA.	-	0, 1	depending on valve
E25 MIN operating threshold	Adjustment of the MIN operating threshold. To match the response sensitivity for the MIN-stroke step.	-	0-200	100
P5 Dither amplitude	Adjustment of dither amplitude. To reduce the influence of solenoid friction.	%	0.0 - 15.0	depending on valve
P6 Dither frequency	Adjustment of dither frequency. To match the dither signal to the valve dynamic.	Hz	0 - 300	depending on valve
P1 Zero adjust	Adjustment of zero position shifting (offset). To compensate asymmetries.	%	-90 - +90	0.0
P3 MAX A	Adjustment of maximum signal span for positive output signal. To match the command signal span to the valve operating range.	%	50.0 - 100.0	depending on valve
P4 MAX B	Adjustment of maximum signal span for negative output signal. To match the command signal span to the valve operating range.	%	50.0 - 100.0	depending on valve
P7 MIN A	Adjustment of stroke step for valve side A at 0.1% command signal. To compensate for the overlap of the valve spool.	%	0.0 - 50.0	depending on valve
P8 MIN B	Adjustment of stroke step for valve side B at 0.1% command signal. To compensate for the overlap of the valve spool.	%	0.0 - 50.0	depending on valve
S5 ramp accel. A	Adjustment of ramp rate for increasing of the negative signal polarity. To avoid switching noise.	ms	0 - 32500	0
S6 ramp decel. AB A	Adjustment of ramp rate for decreasing of the negative signal polarity. To avoid switching noise.	ms	0 - 32500	0
S7 ramp accel. B	Adjustment of ramp rate for increasing of the positive signal polarity. To avoid switching noise.	ms	0 - 32500	0
S8 ramp decel. AB B	Adjustment of ramp rate for decreasing of the positive signal polarity. To avoid switching noise.	ms	0 - 32500	0
J12 Errorhandling	Adjustment of the handling by detecting a fault. For the alignment of the valve reaction at fault diagnosis	-	0, 255, 768, 1023	0

## Operation



If any of the safety features of the product are not operational, the system/machine must be shut down immediately.



Do not carry out any activities that might jeopardize safety.

Note also the information in sections “Warranty and liability”, “Use of operating instructions”, “Compliance with other rules and instructions”, “Personnel requirements”, “Remaining risks”.

## Modification

We define modification as the replacement of a defective valve with a new valve of the same series. In particular, it is not permitted to open the valve.



Make sure that the hydraulic system/machine is unpressurised before the product is installed/removed.

## Service/maintenance



Service work may only be carried out by qualified personnel. Detailed knowledge of the machine functions concerning switching on and off as well as of the required safety relevant technical tasks is required!

Periodical maintenance is essential for the longevity of the system and guarantees reliability and availability. The following properties of the system has to be checked in continuous short time intervals:

- oil level in the tank
- max. working temperature
- condition of the pressure fluid (visual inspection, color and smell of hydraulic fluid)
- working pressure levels
- gas pre-load pressure on the pressure accumulator
- leakage on all system components
- condition of filter elements
- condition of hose lines
- cleanliness of components

After a certain operating duration a change of the hydraulic fluid is required. The frequency of change depends from the following circumstances:

- kind resp. grade of the pressure fluid
- filtering
- operating temperature and environmental conditions

## Air bleeding of hydraulic system

During initial startup, after an oil change as well as after the opening of lines or valves the hydraulic system must be air bled.

## Filter

The function and lifetime of the valve are strongly affected by the cleanliness of the fluid.

Purity level class of 18/16/13 acc. ISO 4406 is required.

## Flushing

It is recommended to flush the pipelines by short circuiting the pressure and return lines. This prevents the installation dirt from entering the valve.

## Decommissioning

Make sure that the hydraulic system/machine is unpressurised before the product is removed. Note also the information in sections “Warranty and liability”, “Use of operating instructions”, “Compliance with other rules and instructions”, “Personnel requirements”, “Remaining risks”.

## Disposal



At the end of the service life of this product

- all escaping pressure fluids must be removed and disposed of properly
- any significant fluids remaining in the product must be removed and disposed of properly
- all materials must be segregated for recycling when they are removed and taken to a suitable recycling center.

Please segregate the packaging material properly (e.g. paper, plastic). None of the components of the product contain hazardous materials.



The normal local environmental protection laws must always be met when disposing of the product.

Note also the information in sections “Warranty and liability”, “Basic information on using the manual”, “Other applicable standards/rules”, “Personnel requirements”, “Remaining risks”.

### Trouble shooting

Basis of troubleshooting is always a systematic approach. At first the following questions have to be checked:

- Are there practical experiences with similar failures?
- Have system adjustments been changed?

Afterwards starting of troubleshooting by means of a priority list of the most likely reasons.

 For suspect of a sluggish spool the valve may be flushed with clean pressure fluid.

 Troubleshooting in a hydraulic system requires in either case a systematic approach. The work may exclusively be performed by qualified personnel, as it requires detailed knowledge about function and construction of the system. Reversals or disassemblies may not be taken imprudently! Prior to the works it has to be clarified, if the system has been operated properly until the failure occurred.

### Troubleshooting table

malfunction at hydraulic load runtime											
- generally no function											
- high frequent oscillation											
- low frequent oscillation											
- one way operation only											
- speed variations at unchanging command											
- different speeds depending on travel direction											
- speed too low											
- drifting without command											
- poor dynamic											
possible reasons for malfunction					corrective actions						
X										hydraulic pump resp. motor defective	replace hydraulic pump resp. motor
X	X	X	X	X	X					drive overloaded	reduce pressure resp. speed, increase valve size
X	X	X	X	X	X	X				valve contaminated	clean pressure fluid, filter / flush valve
			X	X	X					hydraulic fluid too viscous / too cold	change fluid grade, provide operational temperature
X		X	X							too low oil level within tank	refill pressure fluid
			X	X	X					filter contaminated	clean resp. replace filter
X										supply voltage carries too much ripple	reduce ripple
X		X			X					command signal too low	increase command signal
X										command signal carries too much ripple	reduce ripple
			X		X					center position adjustment incorrect	check center position adjustment
X	X		X		X	X				contacts of central connector contaminated	clean contacts / replace plug
X										feed cable interrupted	fix feed cable
X	X	X	X	X	X	X				wiring sequence incorrect	correct wiring sequence
X						X				feed cable without shielding	change cable grade
X										pilot pressure too low or failed	increase pilot pressure to min. 20 bar
		X			X	X				pilot pressure too low	increase pilot pressure to min. 20 bar
						X				pilot pressure too low	increase pilot pressure to min. 50 bar

### 4. Product information

#### Other applicable standards / rules

- ISO 4406:1999-12 Hydraulic fluid power - Fluids - Method for coding the level of contamination by solid particles
- ISO 4401:2005-07 Hydraulic valves; mounting surfaces and connecting plates
- DIN EN 60204-1; VDE 0113-1:2007-06 Safety of machinery – Electrical equipment of machines – Part 1: General requirements
- DIN EN 60529; VDE 0470-1:2000-09 Degrees of protection provided by enclosures (IP code)
- DIN EN 61000-4-2/3/4/6/8 Electromagnetic compatibility
- DIN 51524-1:2006-04 Pressure fluids - HLP hydraulic oils - Part 1: Minimum requirements
- DIN 51525-2:2006-04 Pressure fluids - HLP hydraulic oils - Part 2: Minimum requirements
- German Occupation Safety Ordinance (Betriebssicherheitsverordnung)
- German Labour Protection Act (Arbeitsschutzgesetz)

## Accessories / spare parts

### Accessories

The following accessories are available for the valve series D\*FC/D\*1FC:

#### D1FC:

Bolt kit ordering code BK375

Code 0/1/3/7: female conn. 6+PE  
ord. code 5004072

Code 5: female conn. 11+PE ord. code 5004711

#### D3FC, D31FC:

Bolt kit ordering code BK385

Code 0/1/3/7: female conn. 6+PE  
ord. code 5004072

Code 5: female conn. 11+PE ord. code 5004711

#### D41FC:

Bolt kit ordering code BK320

Code 0/1/3/7: female conn. 6+PE  
ord. code 5004072

Code 5: female conn. 11+PE ord. code 5004711

#### D91FC:

Bolt kit ordering code BK360

Code 0/1/3/7: female conn. 6+PE  
ord. code 5004072

Code 5: female conn. 11+PE ord. code 5004711

#### D111FC:

Bolt kit ordering code BK386

Code 0/1/3/7: female conn. 6+PE  
ord. code 5004072

Code 5: female conn. 11+PE ord. code 5004711

### Spare parts

The following spare parts are available:

#### D1FC:

Seal kit NBR ordering code SK-D1FC

Seal kit FPM ordering code SK-D1FC-V

#### D3FC:

Seal kit NBR ordering code SK-D3FC

Seal kit FPM ordering code SK-D3FC-V

#### D31FC:

Seal kit NBR ordering code SK-D31FC

Seal kit FPM ordering code SK-D31FC-V

#### D41FC:

Seal kit NBR ordering code SK-D41FC

Seal kit FPM ordering code SK-D41FC-V

#### D91FC:

Seal kit NBR ordering code SK-D91FC

Seal kit FPM ordering code SK-D91FC-V

#### D111FC:

Seal kit NBR ordering code SK-D111FC

Seal kit FPM ordering code SK-D111FC-V

Please direct technical product enquiries to:

### Parker Hannifin

### Manufacturing Germany GmbH & Co. KG

Hydraulic Controls Division Europe

Gutenbergstr. 38

41564 Kaarst, Germany

Tel.: (+49) 181 99 44 43 0

E-mail: valveshcd@parker.com

**Hotline in Europe**

**Phone: 00800-2727-5374**

