

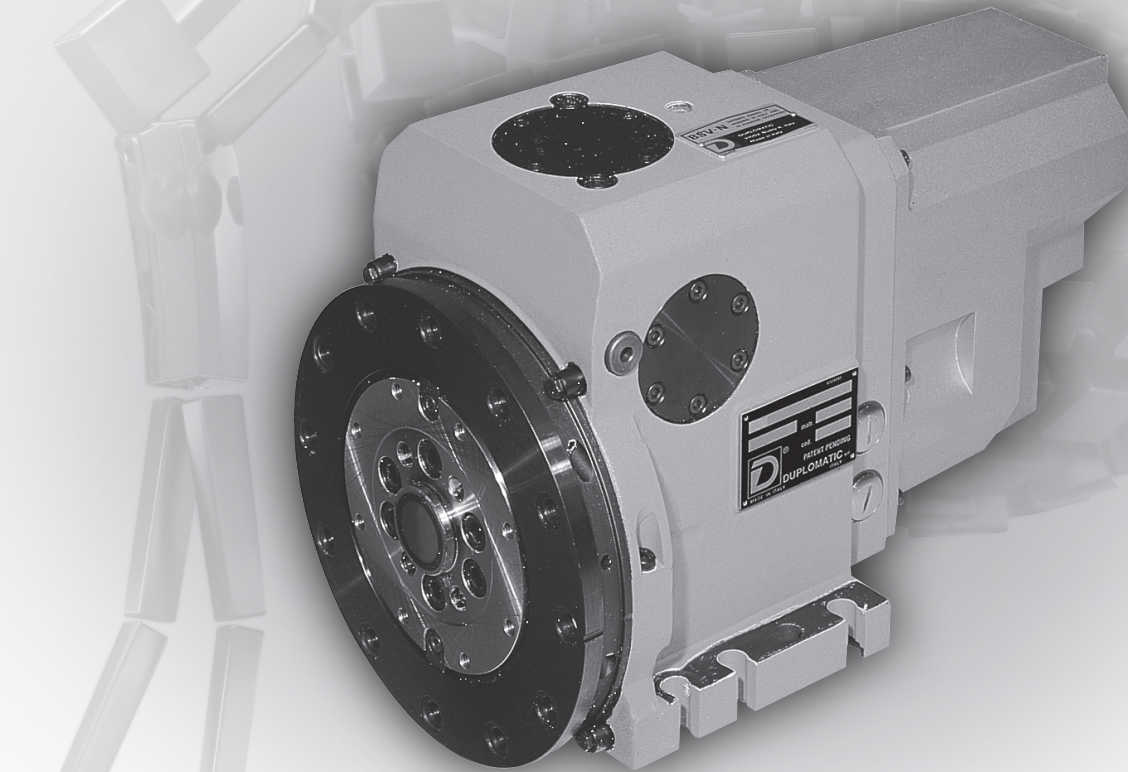

DIPLOMATIC
AUTOMATION



BSV-N series 25

ELECTROMECHANICAL TURRETS

TECHNICAL INFORMATION



I.T. 6430

GB ISSUED **09-08**

The data given in the I.T. are subject to technical modifications without notice.

BSV-N

WORKING PRINCIPLE

Water-proof housing with oil immersed mechanism, life lubricated.

Clamping on 3-part Hirth front tothing
– High stiffness and accuracy
– No lifting during rotation.

Single three-phase electric motor for rotation and clamping.

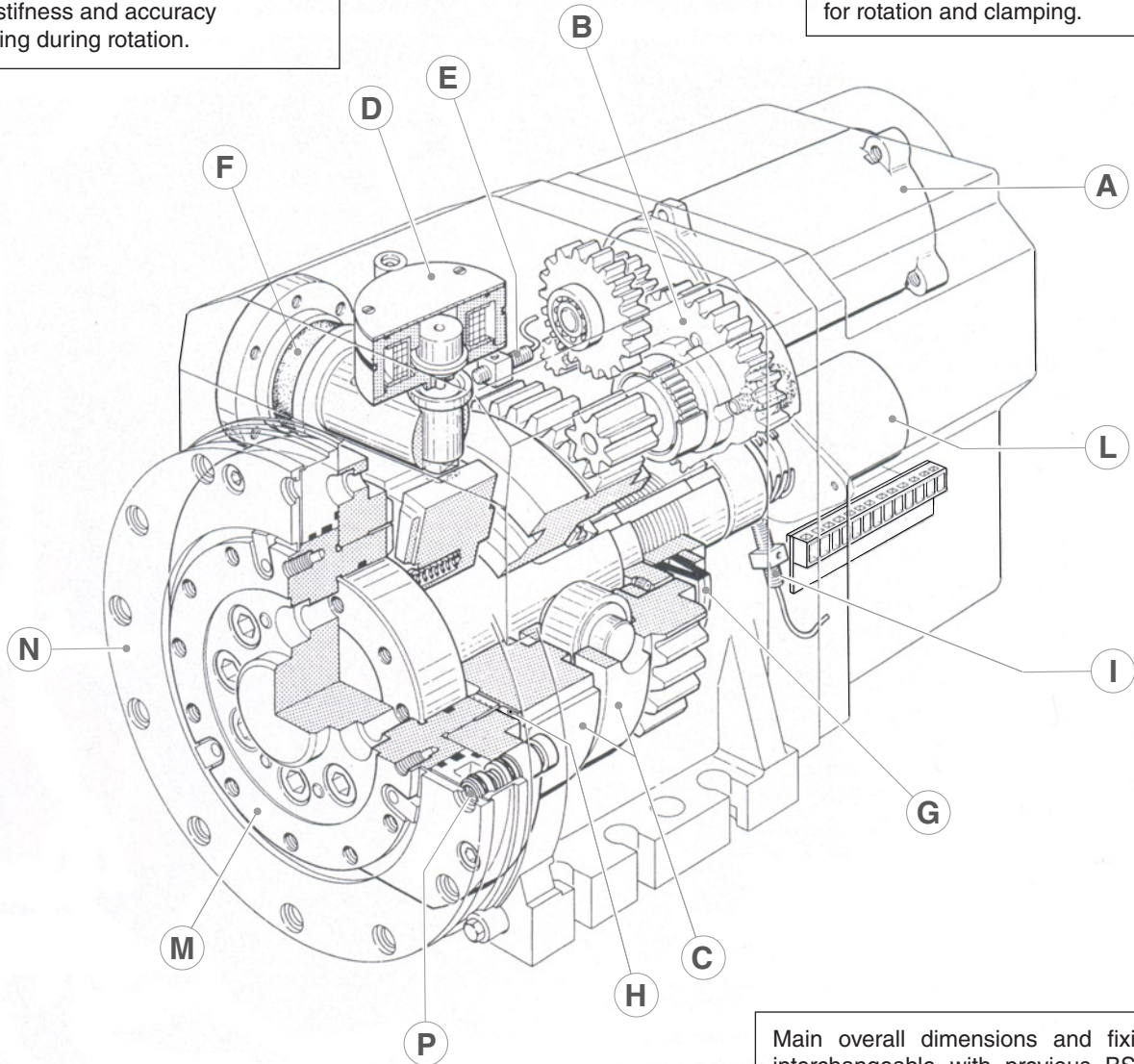

Main overall dimensions and fixings interchangeable with previous BSV-N series and SM turrets.

- | | |
|---------------------------------------|--|
| A) Electrical motor (three-phase) | H) 3-parts front coupling |
| B) Gearbox | I) Locking control switch |
| C) Rotation and cam locking mechanism | L) Angular position transmitter (absolute) |
| D) Pre-indexing solenoid | M) Rotating plate |
| E) Pre-indexing control switch | N) Coolant flange |
| F) Shock-absorber system | P) Quick change coolant valve |
| G) Preloaded locking spring | |

Technical data

Size		BSV-N 120/25			BSV-N 160/25			BSV-N 200/25			BSV-N 250/25		BSV-N 320/24		BSV-N 400/20			
Tool stations	N°	8÷12			8÷12			8÷12			8÷12		8÷12		8÷12			
Version (1)		std	slow	very slow	fast	std	slow	std	slow	very slow	std	slow	std	slow	std	slow	very slow	
Inertia of transportable mass	Kgm ²	0,45	0,8	1,2	0,55	0,9	1,8	3	4,5	8	5	9	15	22	22	32	70	
Indexing time (including locking)	30°	s	0,41	0,48	0,58	0,41	0,48	0,58	0,65	0,78	1	0,78	1	1,10	1,25	1,25	1,45	2,05
	45°	s	0,48	0,57	0,69	0,48	0,57	0,69	0,78	0,94	1,18	0,94	1,18	1,25	1,45	1,45	1,65	2,50
	180°	s	1,16	1,38	1,65	1,16	1,38	1,65	1,83	2,23	2,80	2,23	2,80	2,71	3,18	3,18	3,66	5,53
Rotating time only	30°	s	0,15	0,18	0,21	0,15	0,18	0,21	0,24	0,30	0,36	0,30	0,36	0,33	0,38	0,38	0,45	0,68
	45°	s	0,23	0,27	0,32	0,23	0,27	0,32	0,36	0,45	0,54	0,45	0,54	0,49	0,58	0,58	0,67	1
Indexing frequency $\alpha=90^\circ$	cycle/min	16	14	11	14	12	10	11	9	7	9	7	6	5	5	4	3	
Electric supply		See wiring diagram																
Mass (without disc)	~ Kg	40			52			92			120		240		420			
Ambient temperature range	°C	5 ÷ 40			5 ÷ 40			5 ÷ 40			5 ÷ 40		5 ÷ 40		5 ÷ 40			
Coolant supply: (2)																		
	• Costant flow	bar	7			7			7			7		7		7		
• Pressure cut-off during turret rotation	bar	14			14			14			14		14		14			
Protection degree (DIN 40050)		IP65			IP65			IP65			IP65		IP65		IP65			

(1) Other versions on request.

(2) Filtering $\leq 150 \mu\text{m}$.

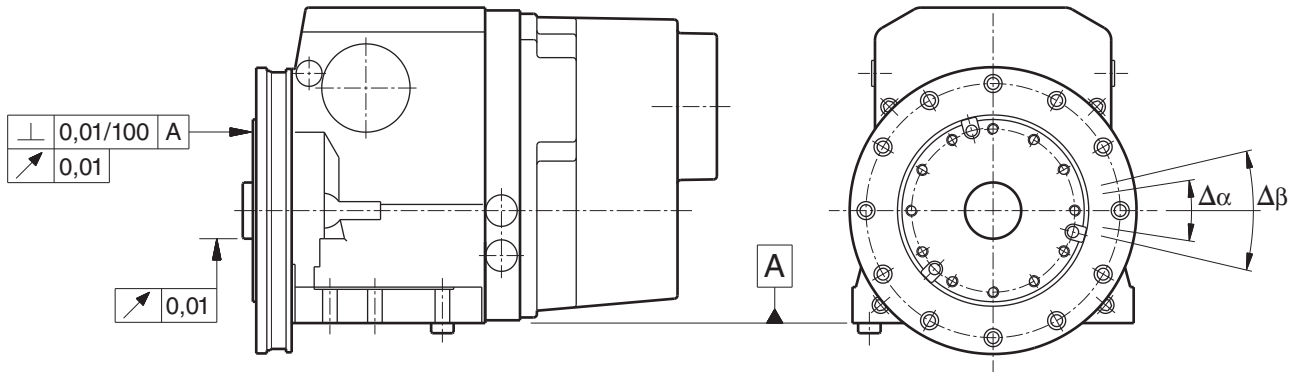

Accuracy



Repeatability accuracy $\Delta\alpha = \pm 1,6''$ (0,78 $\mu\text{m}/100\text{ mm}$)

Indexing accuracy $\Delta\beta = \pm 4''$ (1,9 $\mu\text{m}/100\text{ mm}$)

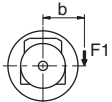
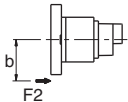
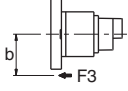
Loading capacity

				BSV-N 120	BSV-N 160	BSV-N 200	BSV-N 250	BSV-N 320	BSV-N 400
	Max. tangential torque	F1xb	Nm	750	1.600	3.500	6.000	12.000	24.000
	Max. tilting torque (to push)	F2xb	Nm	850	1.900	5.200	10.000	16.000	32.000
	Max. tilting torque (to lift)	F3xb	Nm	400	800	2.500	4.000	7.000	15.000
	Unbalancing torque	P x b	Nm	10	12	40	60	120	400

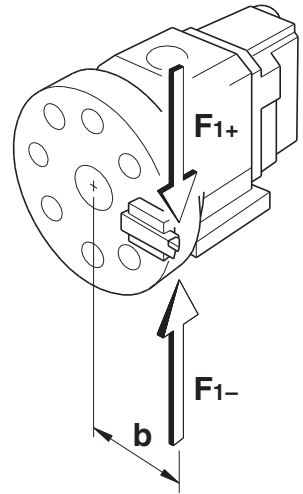
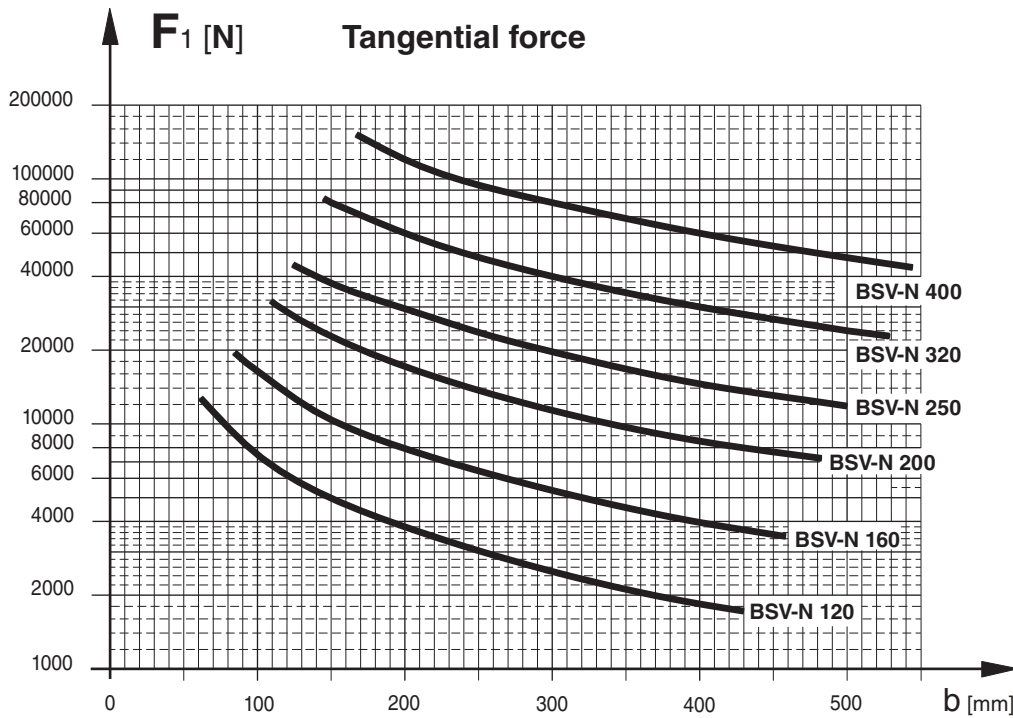

The diagram refers to F_1 values which cause elastic yielding within the rates shown in the schedule.

Turret size		120	160	200	250	320	400
Max. elastic yielding	mm	0,05	0,07	0,08	0,14	0,12	0,16
Distance from centre of measuring point	mm	140	170	220	270	330	350

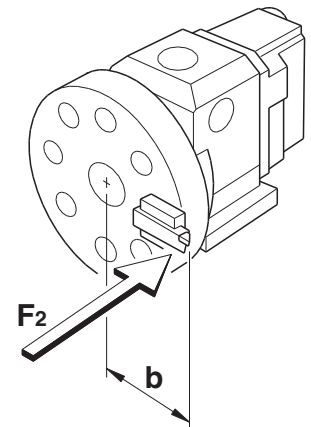
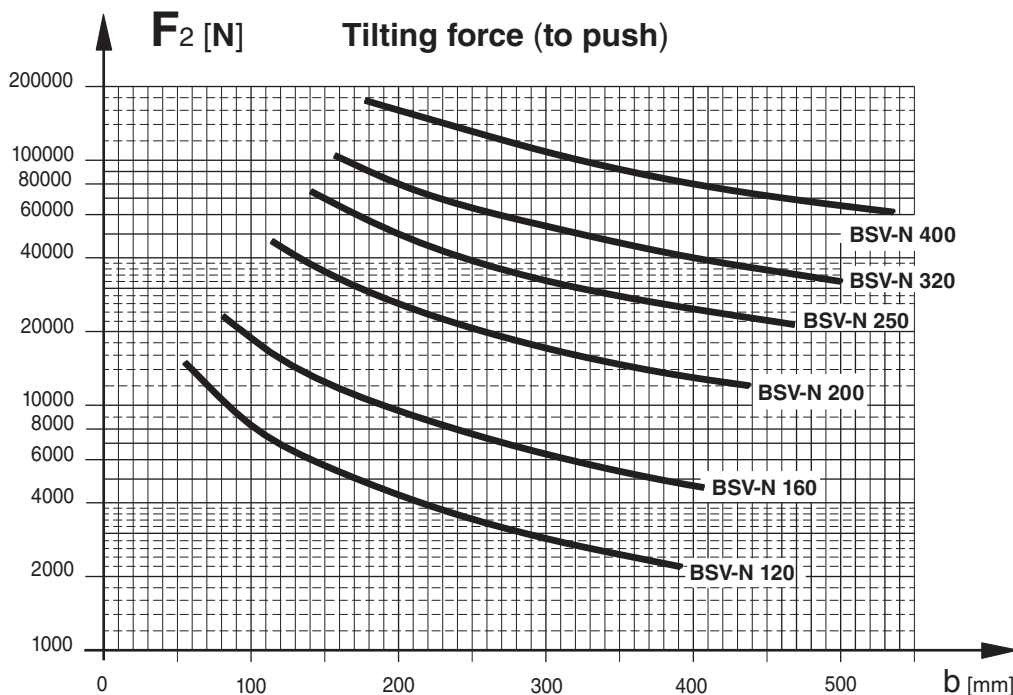

BSV-N

DUTY PERFORMANCES

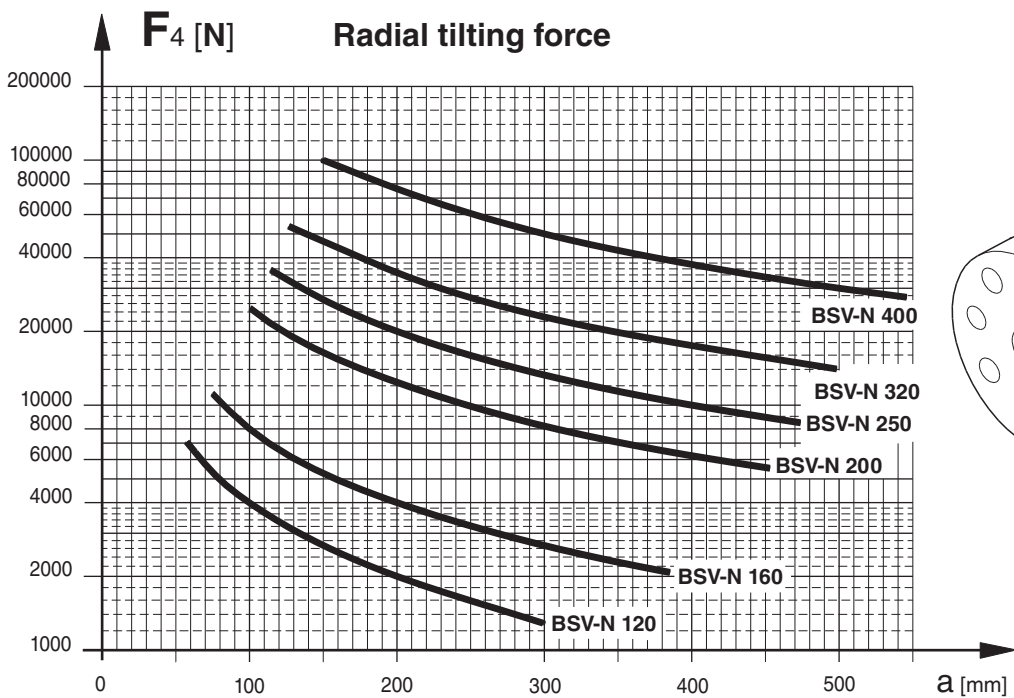
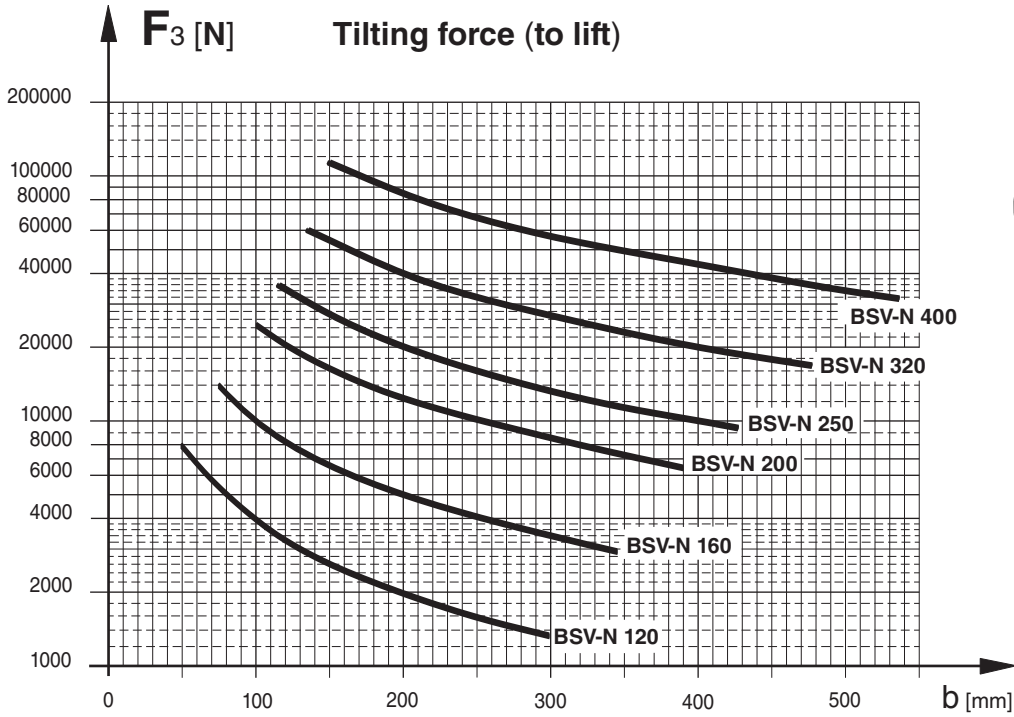

BSV-N

PARAMETERS FOR TURRET SELECTION

S: CHIP CROSS-SECTION (max) for steel R = 600 N/mm² K_s = 2.200 N/mm²

N: POWER (max) for V_t = 200 m/min

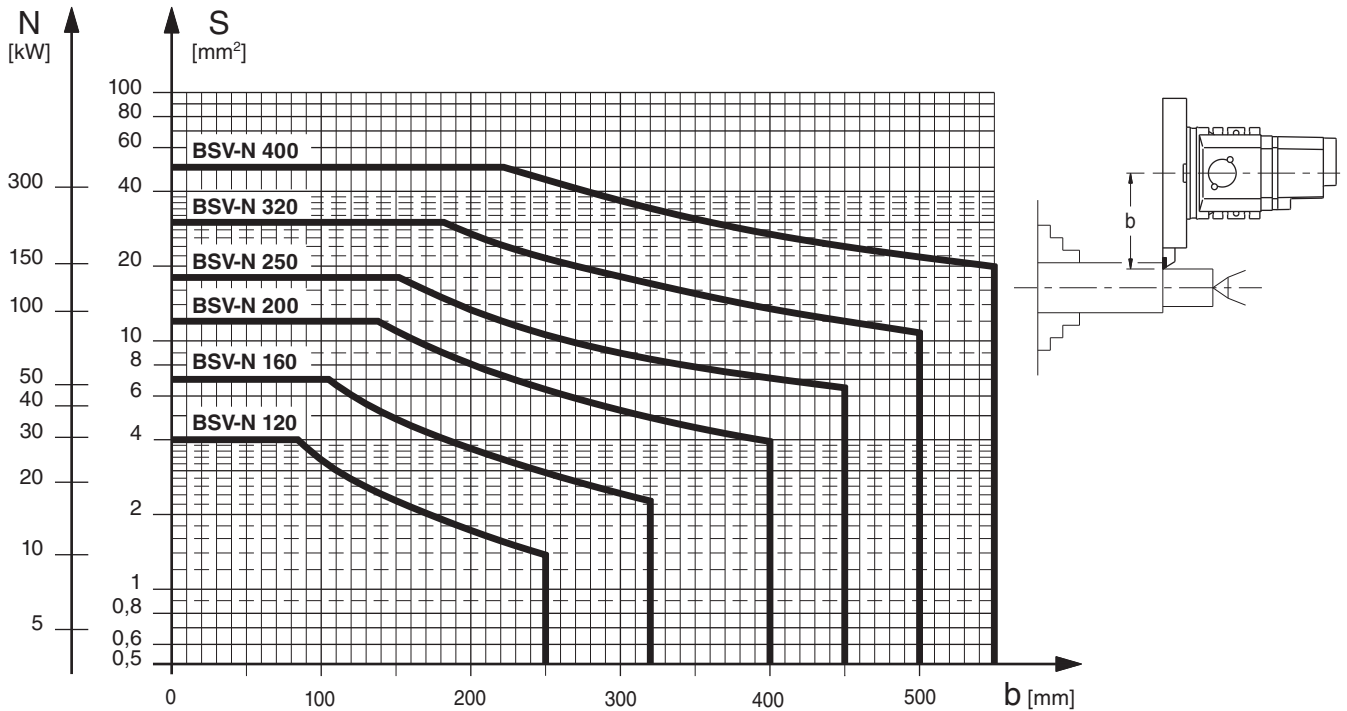

• For any material with different K_s:
$$S_x = \frac{S \times 2.200}{K_x}$$

• For different cutting speeds:
$$N_x = N \times \frac{V_{tx}}{200}$$

BSV-N 320/24

OVERALL DIMENSIONS

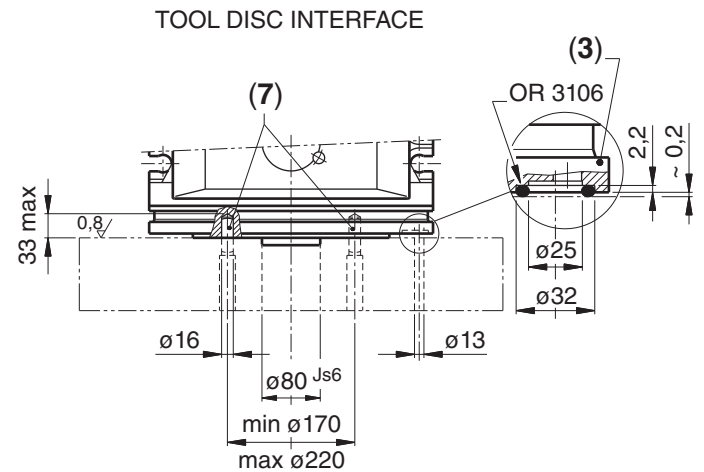
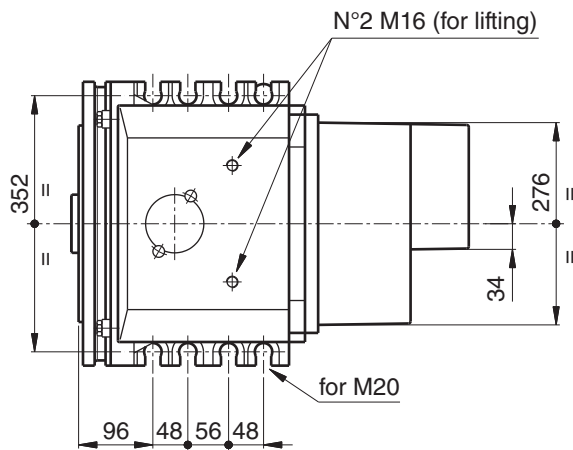
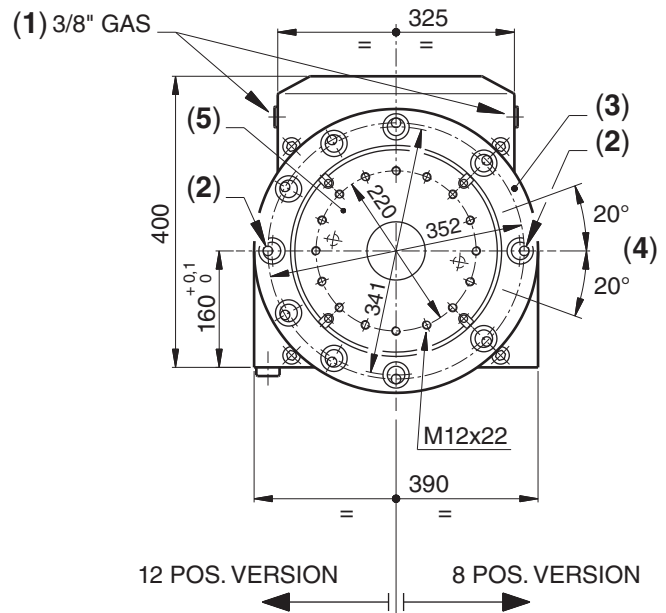
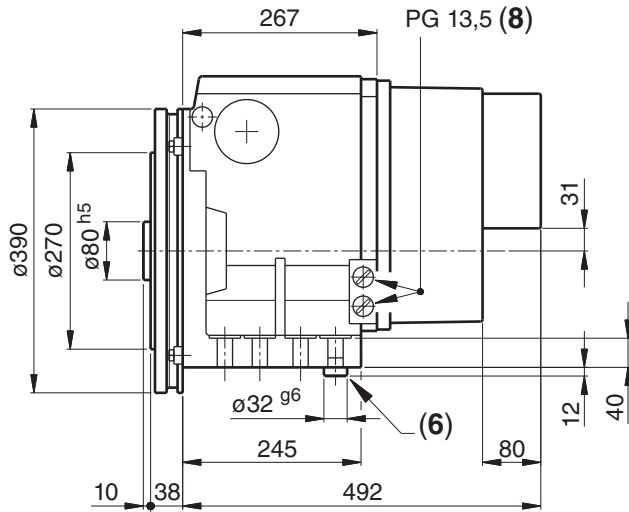





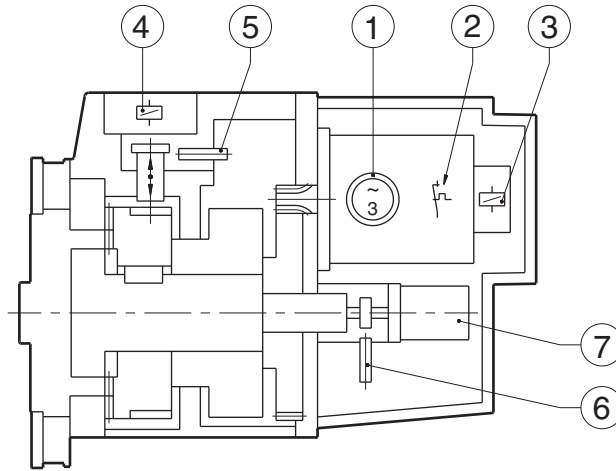

- 1) Inlet coolant position, at choice.
 - 2) Right or left coolant outlet position.
 - 3) Adjustable coolant ring.
 - 4) Coolant outlet displacement range.
 - 5) Soft surface for boring the disc reference pins.
 - 6) Reference pin to be positioned on both side, at choice.
 - 7) Reference pins between tool disc and turret.
 - 8) Electrical connections on both side, at choice.
- Important:** The connection cable must be provided with fittings and gaskets in order to avoid penetration of water into the turret.

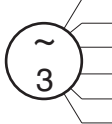
BSV-N

WIRING DIAGRAM

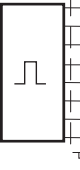

REF.	COMPONENT	CHARACTERISTICS	WIRING NUMBER		SIGNALS
			SYMBOLS	COLOUR	
1	ELECTRIC MOTOR (three-phase)	(1) 220-380 V 50/60 Hz For other characteristics see Tab. 1		U1 WHITE V1 GREEN W1 BLACK U2 WHITE V2 GREEN W2 BLACK	See Tab. 2
2	THERMAL DETECTOR	135 °C 1,5A 250V		1 BROWN 2 BROWN	(2)
3	BRAKE	24 V D.C. BSV-N 120/160 = 8 W BSV-N 200/400 = 12 W		3 GREEN 4 GREEN	
4	INDEXING SOLENOID	24V D.C. 44 W		5 BLUE 6 BROWN	
5	INDEXING CONTROL SWITCH	24V D.C. ± 10% 200 mA (load) OUTPUT-PNP-NO		7 BROWN 8 BLACK 9 BLUE	+ V D.C. EXIT 0 V D.C.
6	LOCKING CONTROL SWITCH			7 BROWN 10 BLACK 9 BLUE	+ V D.C. EXIT 0 V D.C.
7	ANGULAR POSITION TRANSMITTER (ABSOLUTE)	24 V D.C. ± 10% 350 mA (supply) 50 mA/exit (load) OUTPUT-PNP		7 BROWN 9 BLUE 11 WHITE 12 YELLOW 13 GREEN 14 VIOLET 15 BLACK 16 PINK	+ V D.C. 0 V D.C. Bit 1 Bit 2 Bit 3 Bit 4 Strobe Parity check
				GREEN / YELLOW	PE

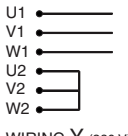
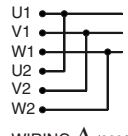
ELECTRIC MOTOR CHARACTERISTICS			Tab. 1	ELECTRIC MOTOR'S WIRING (1)		Tab. 2
Turret size	Minimum required power	Short circuit power				
BSV-N 120/160	KVA 1,10	KVA 1,60		U1 V1 W1 U2 V2 W2	U1 V1 W1 U2 V2 W2	
BSV-N 200/250	KVA 1,80	KVA 2,80		WIRING Y (380 V)	WIRING Δ (220 V)	
BSV-N 320/400	KVA 2,60	KVA 3,80				

(1) Other voltages on request.

(2) The thermal detector gives a signal only motor overheating.

BSV-N CYCLE

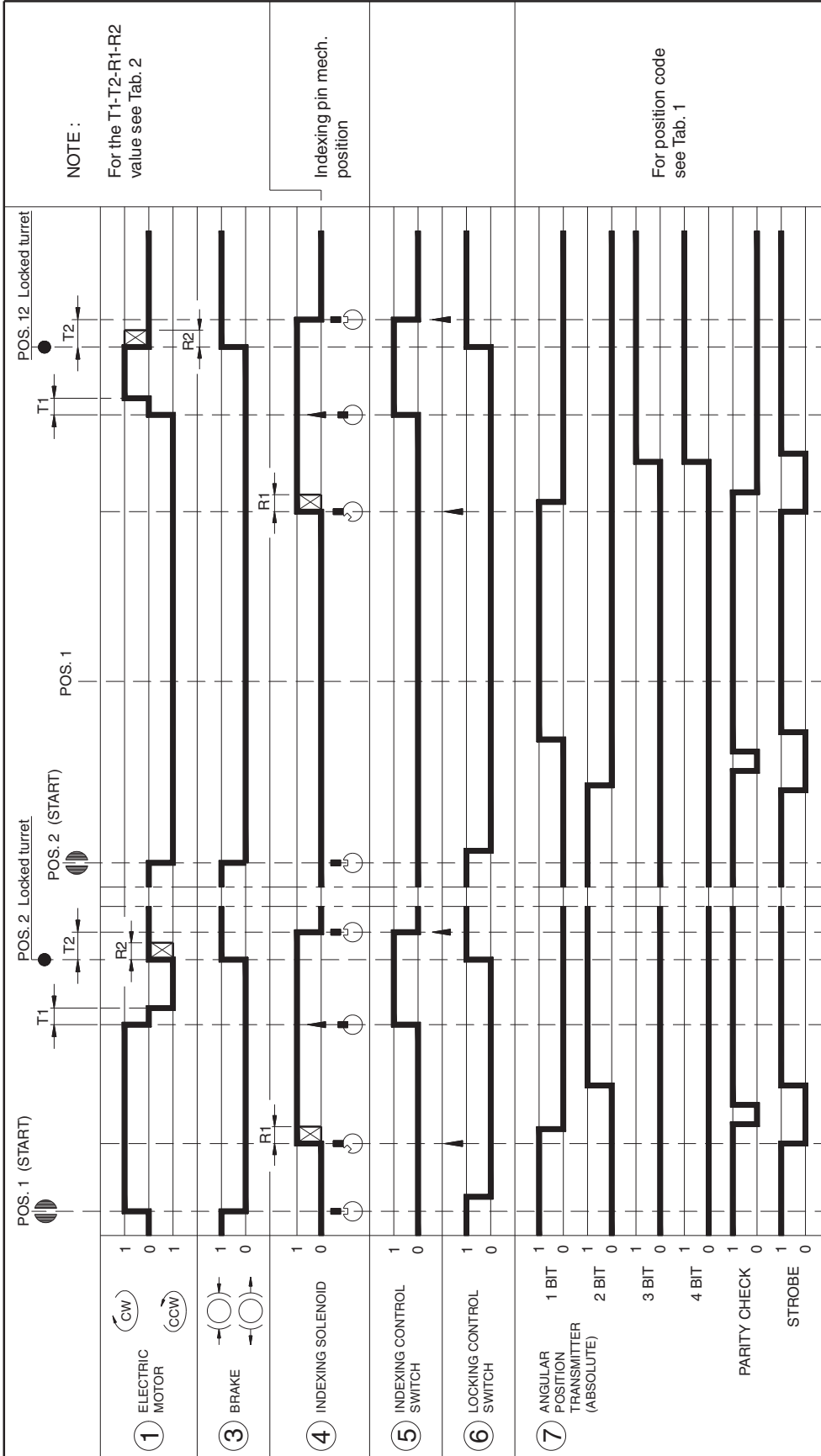

Tab. 2

TURRET SIZE	120	160	200	250	320	400
	T1 (ms)	50	50	50	50	100
PROGRAMMING TIME	200		200	200	200	200
ALLOWED LAG TIME MAX	Standard and fast		40	50	70	70
	Slowed		40	60	70	80
R1 (ms)	Standard		40	70	80	90
R2 (ms)	Slow and very slow		40	80	100	100

Tab. 1

FUNCTION	POSITIONS											
	1	2	3	4	5	6	7	8	9	10	11	12
1 BIT	1	0	1	0	1	0	1	0	1	0	1	0
2 BIT	0	1	1	0	0	1	1	0	0	1	1	0
3 BIT	0	0	0	1	1	1	1	0	0	0	0	1
4 BIT	0	0	0	0	0	0	0	1	1	1	1	1
PARITY CHECK	1	1	0	1	0	0	1	1	0	0	1	0
STROBE	1	1	1	1	1	1	1	1	1	1	1	1

CW → ← CCW

1. – Signals

To get a change of positions on the BSV-N turrets, the control equipment (usually a N.C. equipment) must control the components mentioned below according to a well defined sequence (see wiring diagram on page 15).

- Motor (1)
- Brake (3)
- Indexing solenoid (4)

The following output signals from the turret are provided for driving the positioning cycle:

- Angular position given by the angular position transmitter (7)
- Indexing control switch (5)
- Locking control switch (6).

1. – Description of the operating sequence

This description refers to sequence cycle: the first part gives the sequence to pass from position 1 to position 2 with clockwise rotation, the second part gives the sequence to pass from position 2 to position 12 with counterclockwise rotation.

As indicated by the cycle, the controls are to be performed according with the following sequence:

- De-energize the brake (3) and start motor rotation in the desired direction.

- If, as in the case shown by the diagram, the next position (pos. 2) is the Stop position, when the strobe signal reached a zero level, the solenoid (4) is to be energized.

In case of passage from position 2 to position 12, wait for the reading signaling the passage on pos. 1 then, since the next one is the Stop position, wait until the next strobe signal reaches a zero level and (at that time only) energize the solenoid (4).

N.B.: The maximum lag time between the reading of the strobe signal and the excitation of the solenoid (4) cannot exceed the R1 values indicated in the table.

- The turret goes on rotating until the indexing pin, pushed by the solenoid (4), enters into the mechanical stop slot.

This movement is detected by the sensor (5) which must immediately stop the motor that, once expired the T1 time will re-start rotating in the opposite direction.

- During this phase the turret is locking and its locked position is detected by the sensor (6) and this signal is used to stop the motor (1). The maximum lag time between the signal of the sensor and the stopping of the motor must never exceed the R2 value shown in the table. At this point the machine can be started, in order to go on working.

- The solenoid (4) is to be de-energized after the expiration of the T2 lag time starting from the moment when the sensor (6) signal is read.

N.B.: The T1, T2, R1, R2 times must be understood as real times execution of the controls and the signals checked on the terminal board of the turret.

For an accurate detection and measurement of the above mentioned values it is advisable to use adequate instrumentation such as an oscilloscope with memory and current sensing devices.

Flow chart

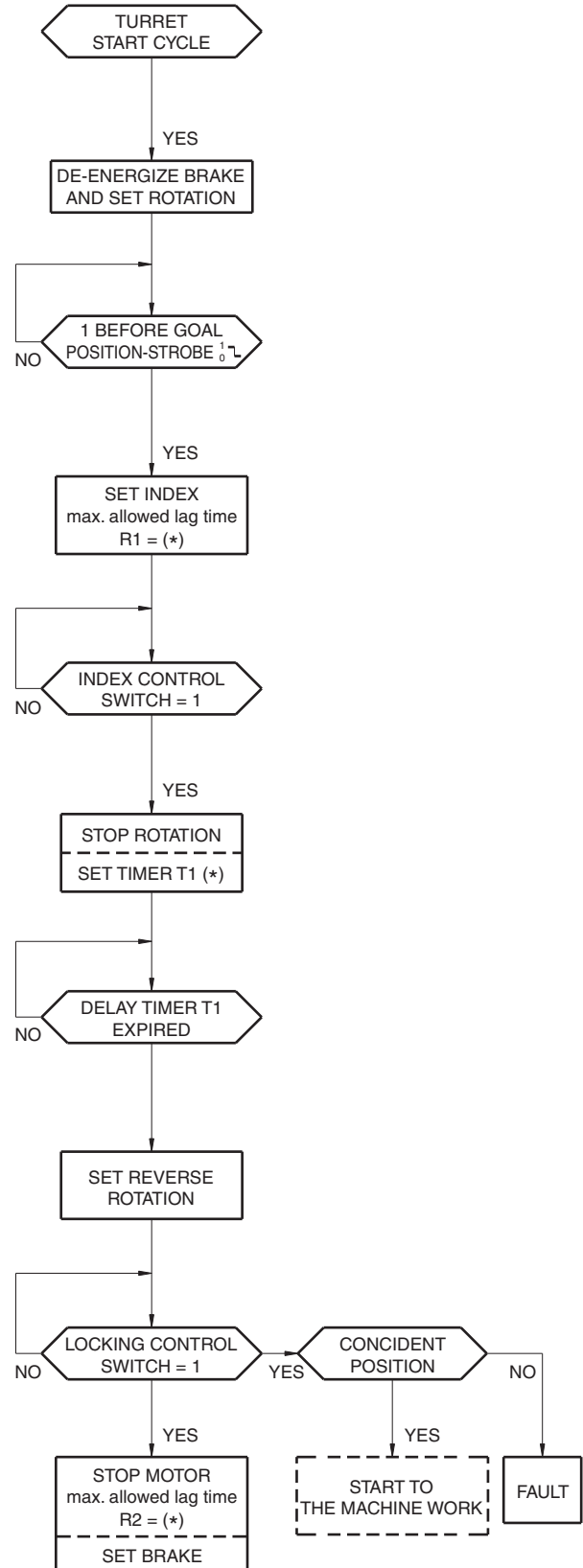

(*) See tab. 2 sheet 16 (Cycle).

"PA" VERSION TURRETS (with axial through-bore)

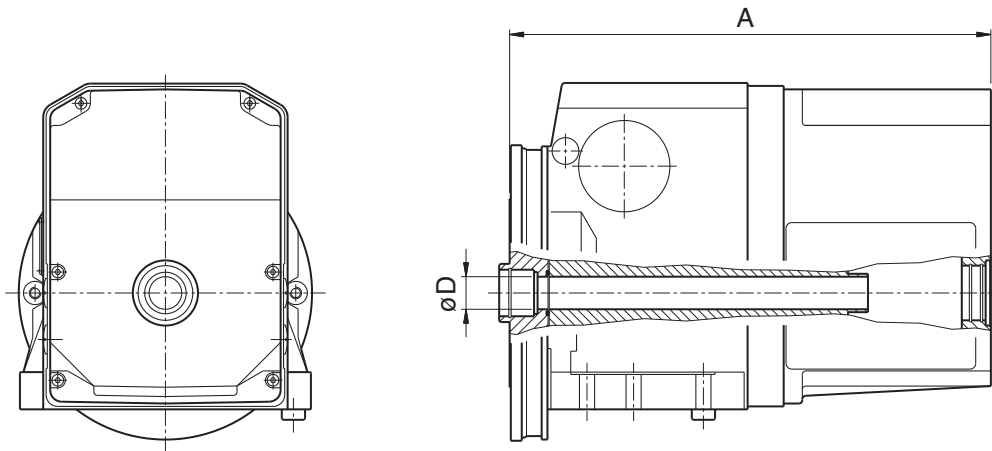

Turret size	BSV-N 120	BSV-N 160	BSV-N 200	BSV-N 250	BSV-N 320	BSV-N 400
ø D	20	20	28	28	28	60
A	370	370	413	413	530	588

DRIVEN TOOLS SYSTEM

"BSV-N*" turrets have been designed for modular fitting onto the different driven tool systems.

BS*-DT

- With **ODT-N** driven tool device.
- Tool coupling according to DIN 1809.
- Tool disc with **axial** seats.
- Front machining.

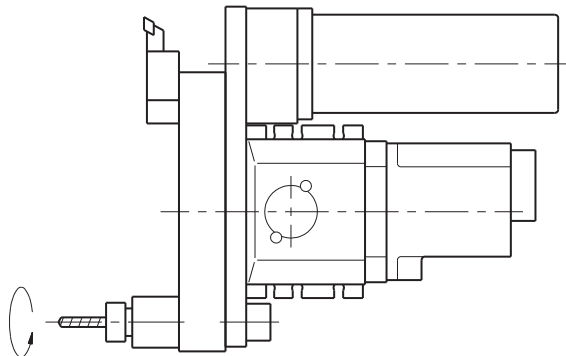

BS*-TR

- With **IDT-R** driven tool device.
- Tool disc with **radial** seats.
- Front machining.

NOTE: Front and **back machining** for **sub-splinde** machines is also available on request.

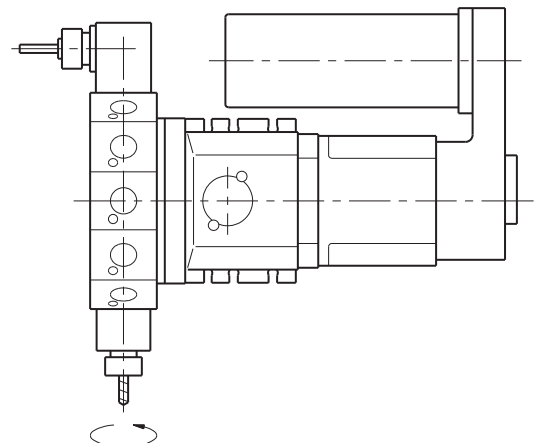

For further information please contact our Technical Dept.

UCN CONTROL UNIT

The UCN control unit manages the moving cycle of BSV-N turret in a simple and optimized way: simple and optimized software; no memory positions are occupied in the machine control; automatic chose of the shortest path; steady monitored for faults.

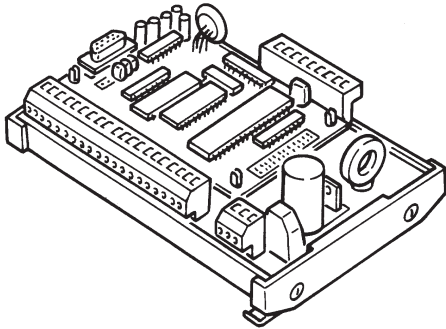

For other information see the Technical Information UCN-*

IDENTIFICATION CODE

BSV-N * - * - * /2* - * - * - (*)

SIZE	CODE
120	120
160	160
200	200
250	250
320	320
400	400

AXIAL THROUGH BORE	CODE
Without (Standard)	—
With (Optional)	PA

POSITIONS	CODE
Nr. 8 Pos.	8
Nr. 12 Pos.	12

SERIE **20 ÷ 29** (1)

OPTIONALS

CODE	FREQUENCY and INERTIA
50 H	50 Hz Fast
60 H	60 Hz Fast
50	50 Hz Standard
60	60 Hz Standard
50 L	50 Hz Slow
60 L	60 Hz Slow
50 LL	50 Hz Very slow
60 LL	60 Hz Very slow

MOTOR VOLT. and FREQUENCY	
220-380	220-380 V - 50/60 Hz
230-400	230-400 V - 50/60 Hz
400-440	400-440 V - 50/60 Hz

(1) From 20 to 29 the performance and the overall dimensions do not change.

DIPLOMATIC AUTOMATION S.r.l.
20025 LEGNANO (MI) - ITALY
P.LE BOZZI, 1
PHONE 0331/472111
FAX 0331/455161



DIPLOMATIC
AUTOMATION

e-mail: info@diplomatic.it

come visit Diplomatic homepage:
www.diplomaticautomation.com