

| REVISION HISTORY | | | |
|------------------|-------------|------|----------|
| REV | DESCRIPTION | DATE | APPROVED |
| | | | |

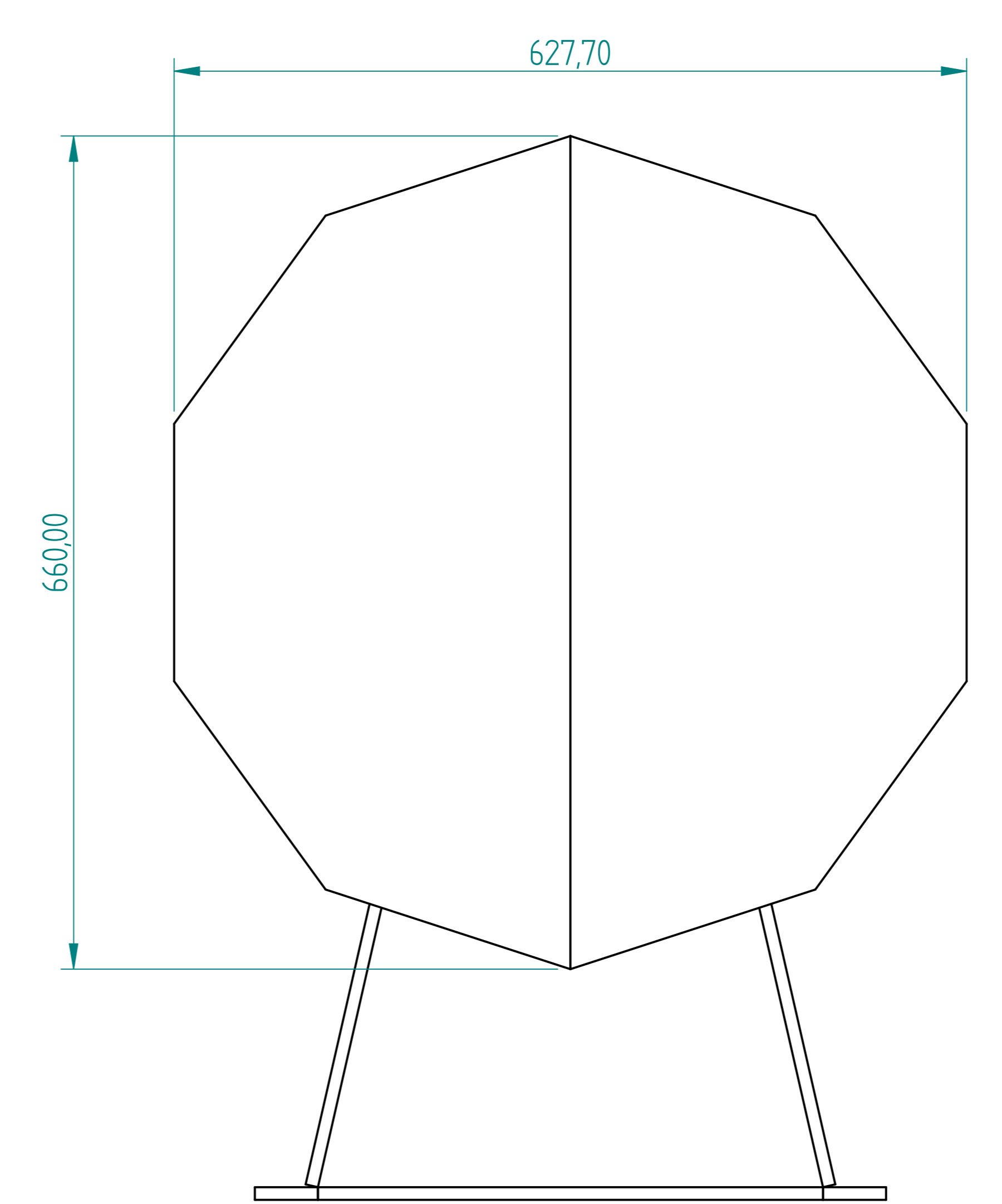

Tumbler

| | | | | | |
|-------------------------------|--|------|----------|---------------|---------------------|
| DRAWN | | NAME | DATE | PREMAC | |
| APPROVED | | | 05/03/23 | TITLE | |
| MATERIAL | | | | Tumbler | |
| TREATMENT | | | | REV | |
| UNLESS OTHERWISE SPECIFIED | | | | SIZE | DWG NO |
| DIMENSIONS ARE IN MILLIMETERS | | | | A4 | |
| ANGLES: 90° | | | | FILE NAME | Tumbler.dwg |
| 2 PL ±0.02 3 PL ±0.005 | | | | SCALE | WEIGHT SHEET 1 OF 6 |

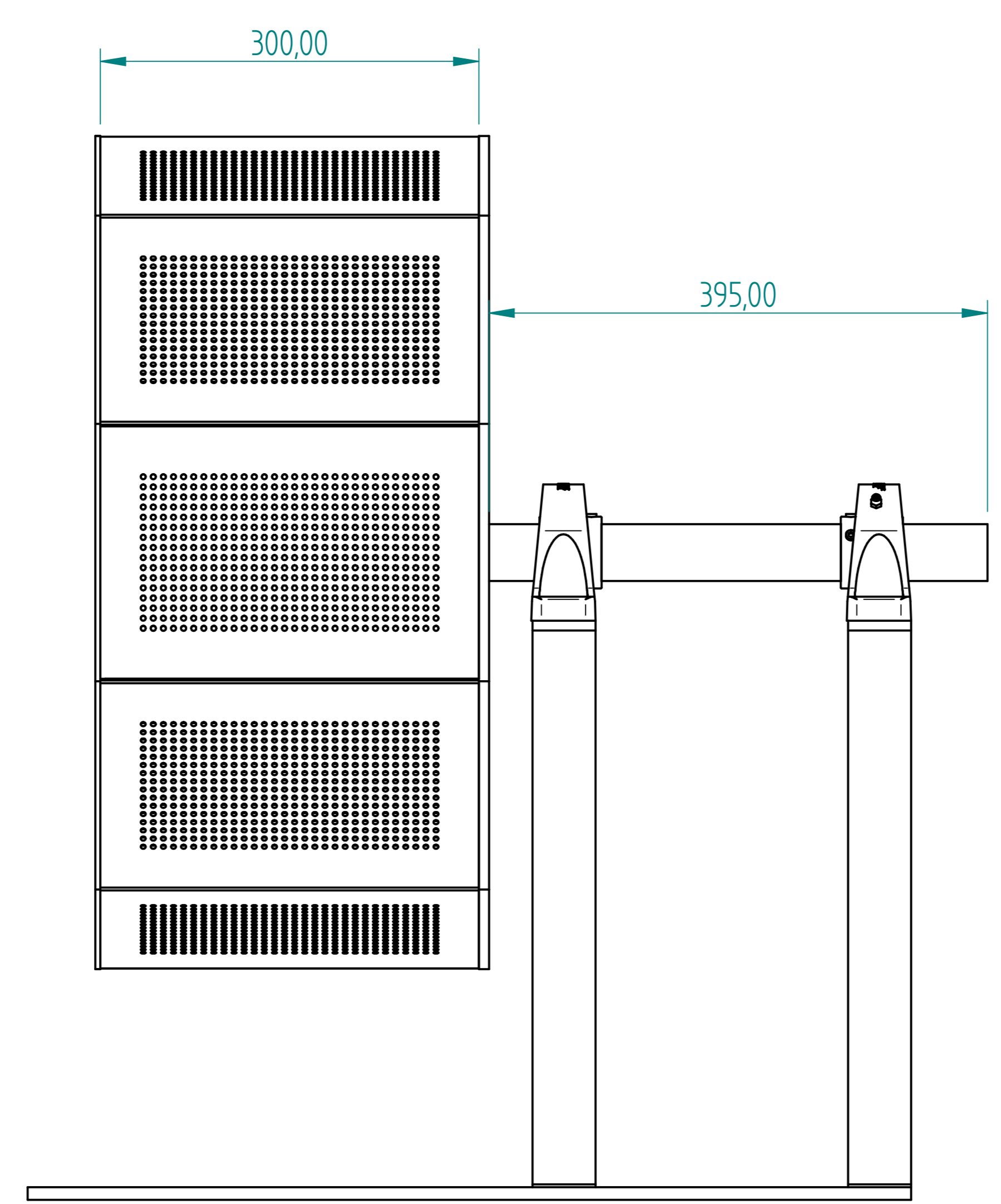
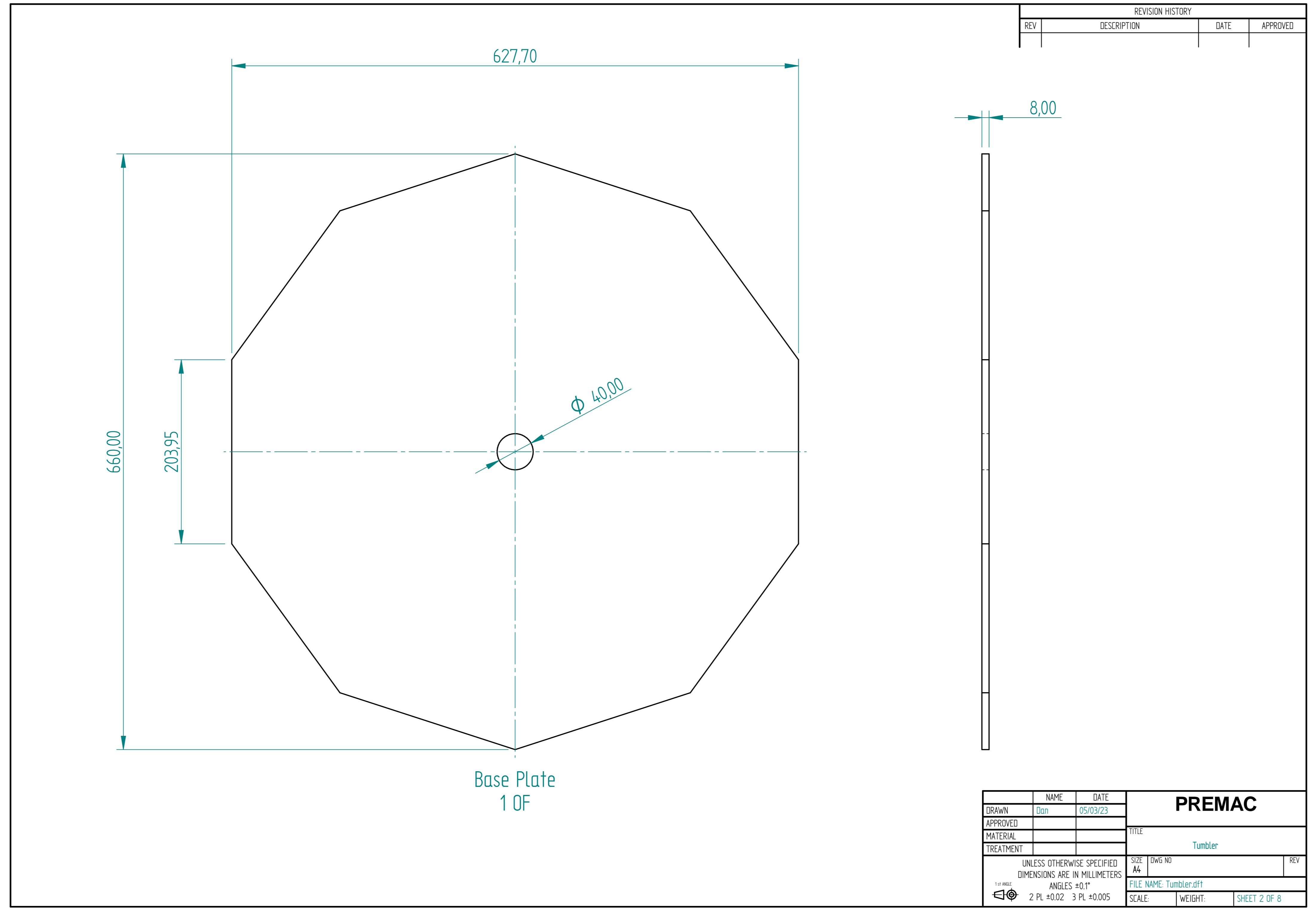

| REVISION HISTORY | | | |
|------------------|-------------|------|----------|
| REV | DESCRIPTION | DATE | APPROVED |
| | | | |

| | | | | |
|-------------------------------|-----|----------|---------------|-------------|
| DRAWN | Edm | 05/03/23 | PREMAC | |
| APPROVED | | | TITLE | |
| MATERIAL | | | Tumbler | |
| TREATMENT | | | SIZE | REV |
| UNLESS OTHERWISE SPECIFIED | | | 1/4" | |
| DIMENSIONS ARE IN MILLIMETERS | | | FILE NAME | Tumbler.dwg |
| ANGLES 90° | | | SCALE | WEIGHT |
| 2 PL ±0.02 3 PL ±0.005 | | | SHEET 2 OF 8 | |

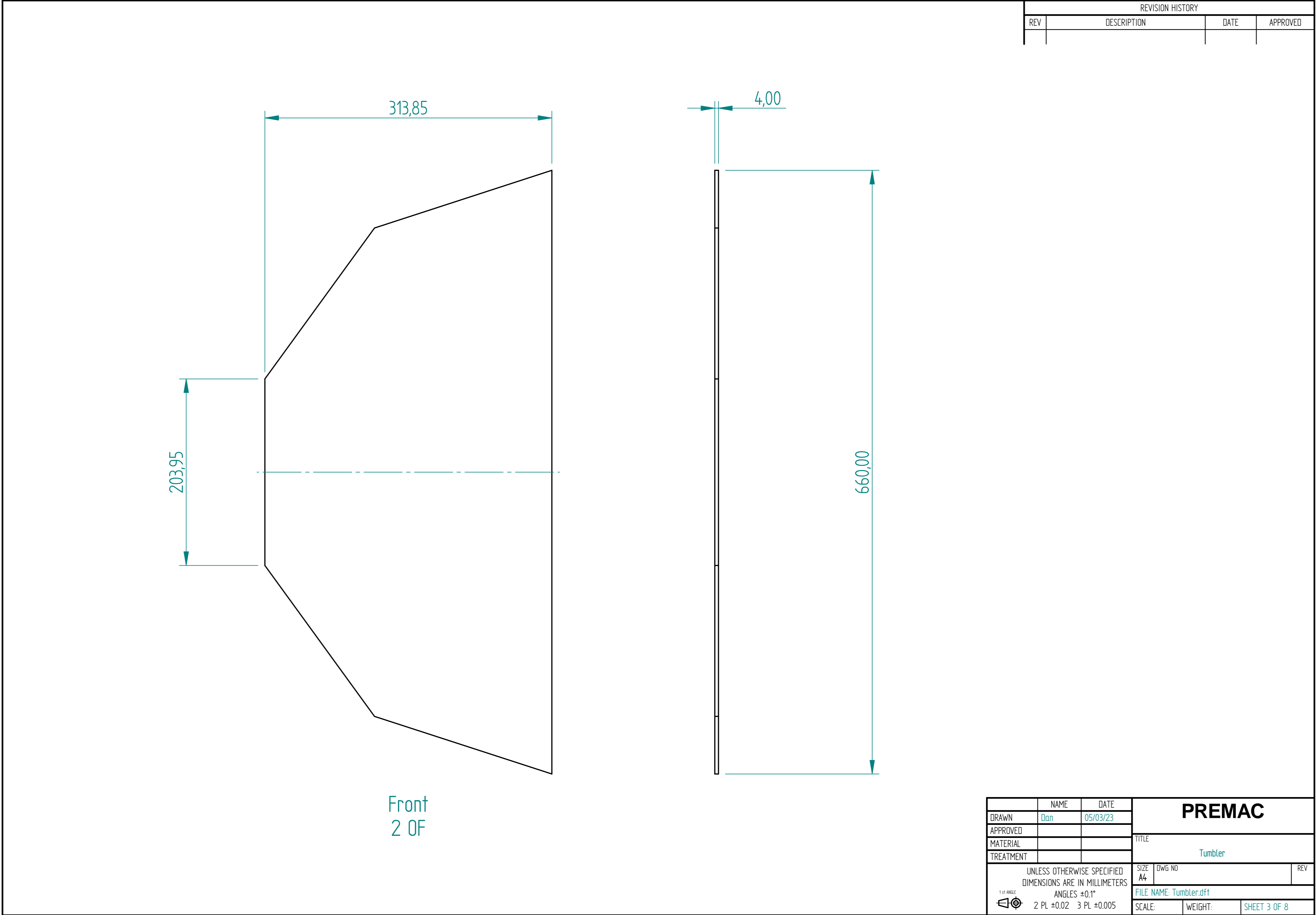

| REVISION HISTORY | | | |
|------------------|-------------|------|----------|
| REV | DESCRIPTION | DATE | APPROVED |
| | | | |

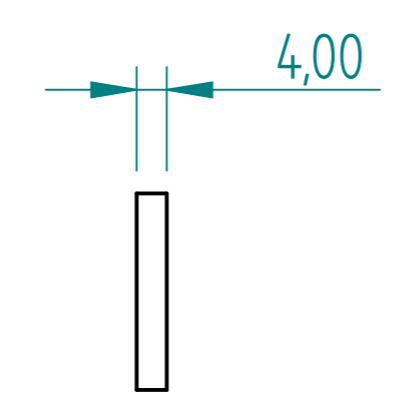
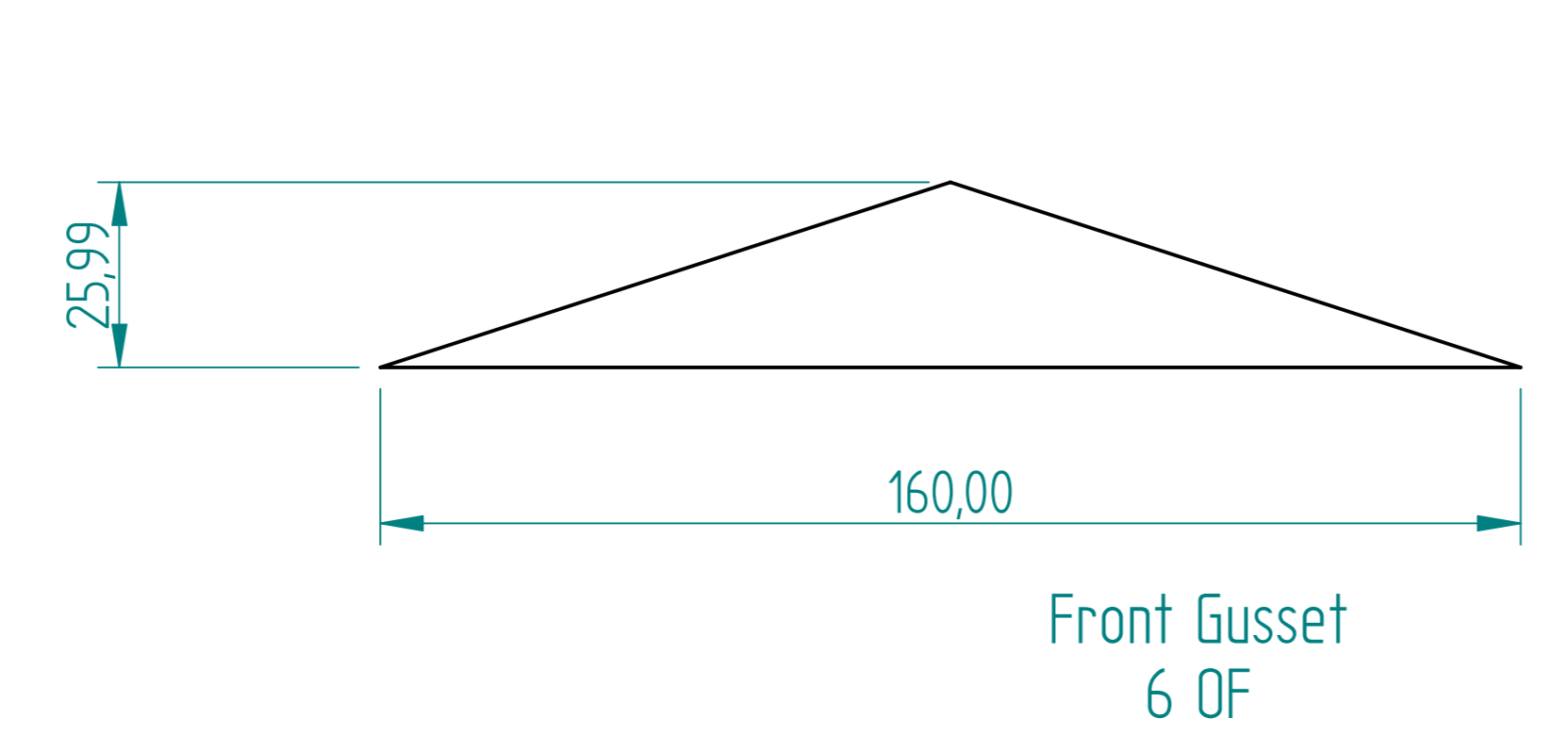
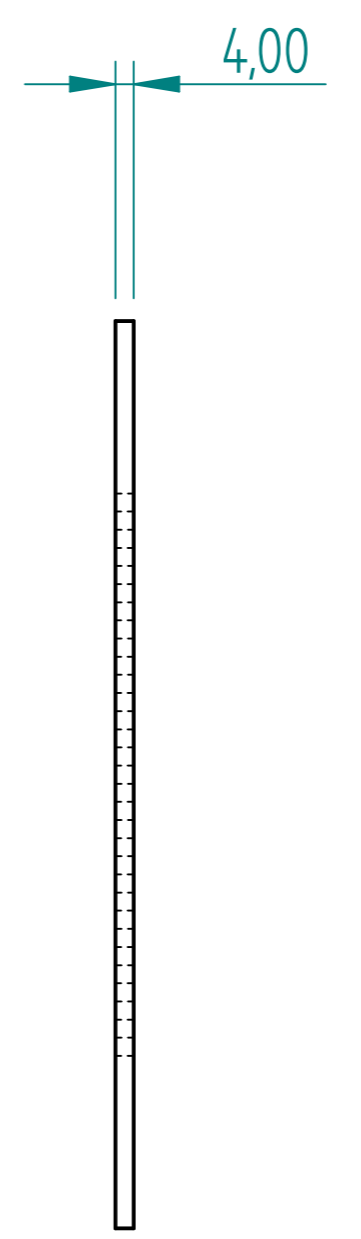
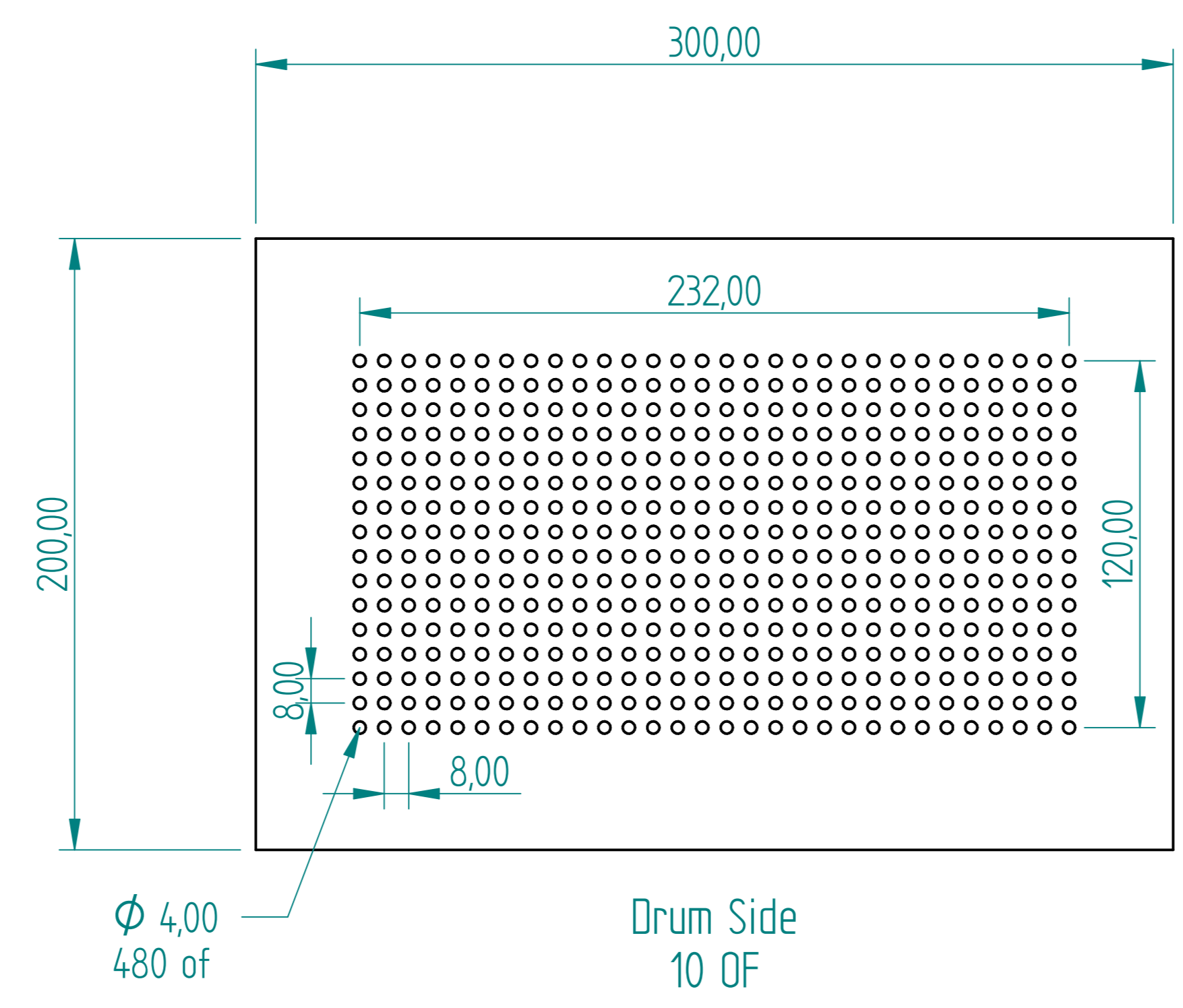

| | | | | | |
|-------------------------------|--|-------|----------|---------------|-------------|
| DRAWN | | NAME | DATE | PREMAC | |
| APPROVED | | | 05/03/23 | | |
| MATERIAL | | | | | |
| TREATMENT | | | | | |
| UNLESS OTHERWISE SPECIFIED | | | | SIZE | REV |
| DIMENSIONS ARE IN MILLIMETERS | | | | A4 | |
| ANGLES 90° | | | | FILE NAME | Tumbler.dwg |
| 2 PL ±0.02 3 PL ±0.005 | | SCALE | WEIGHT | SHEET 4 OF 8 | |

