

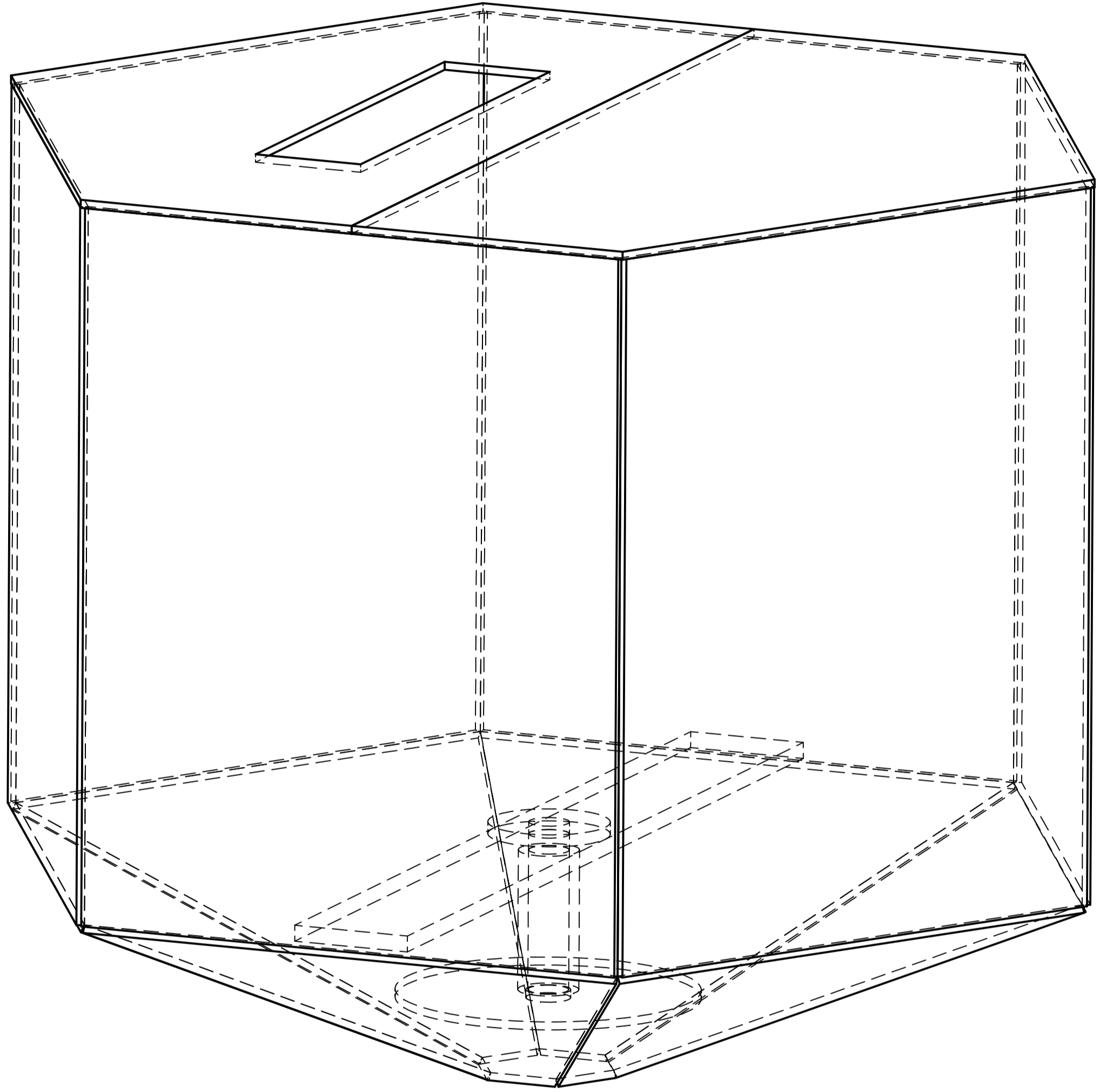

REVISION HISTORY			
REV	DESCRIPTION	DATE	APPROVED



Housing

	NAME	DATE	<b>PREMAC</b>	
DRAWN	Dan	08/10/23		
APPROVED			TITLE	
MATERIAL				
TREATMENT				
UNLESS OTHERWISE SPECIFIED DIMENSIONS ARE IN MILLIMETERS ANGLES ±0.1°			SIZE A4	DWG NO
 2 PL ±0.02 3 PL ±0.005			FILE NAME: Shot Blaster.dft	REV
			SCALE:	WEIGHT:
			SHEET 2 OF 12	

REVISION HISTORY			
REV	DESCRIPTION	DATE	APPROVED

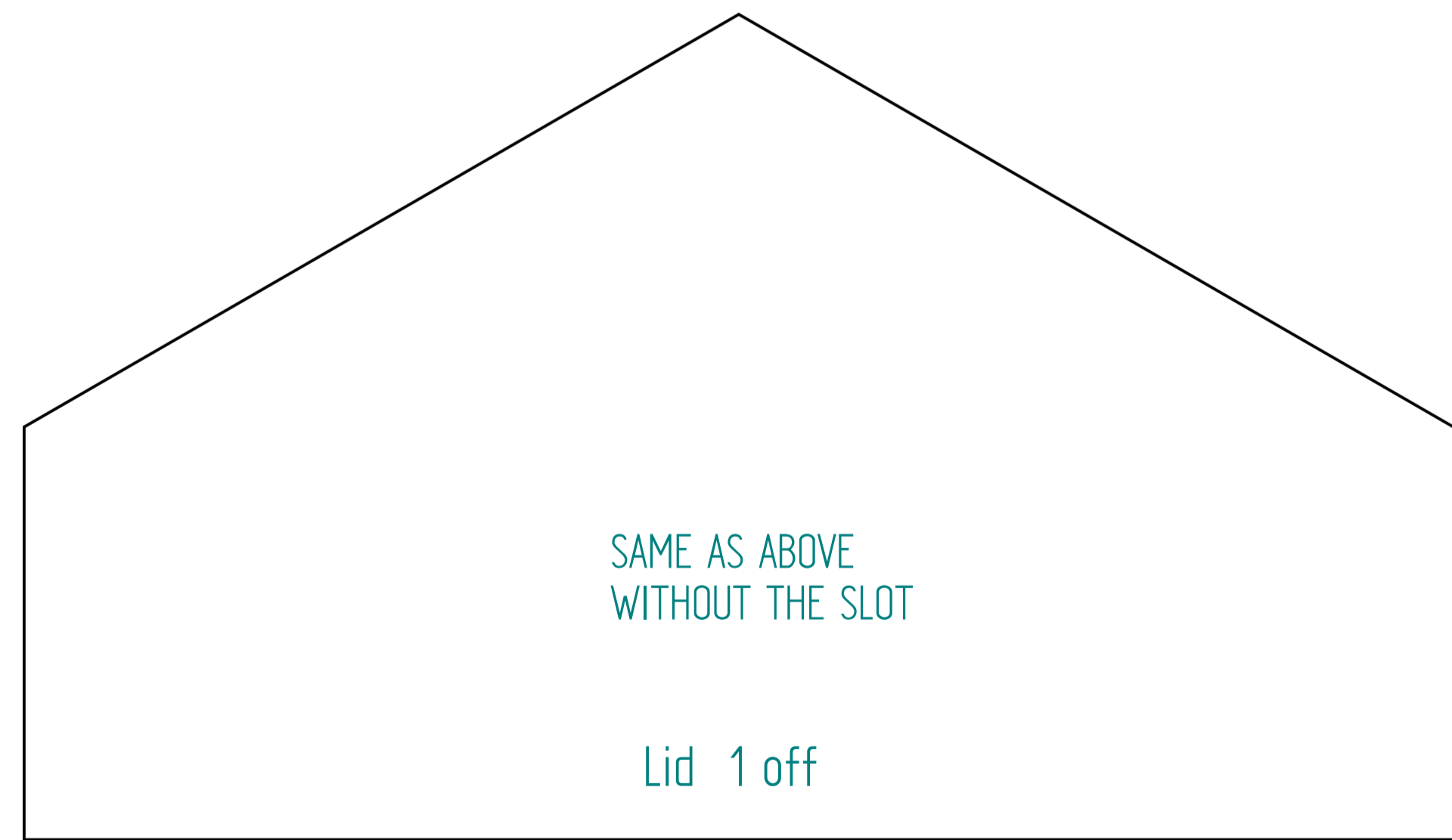
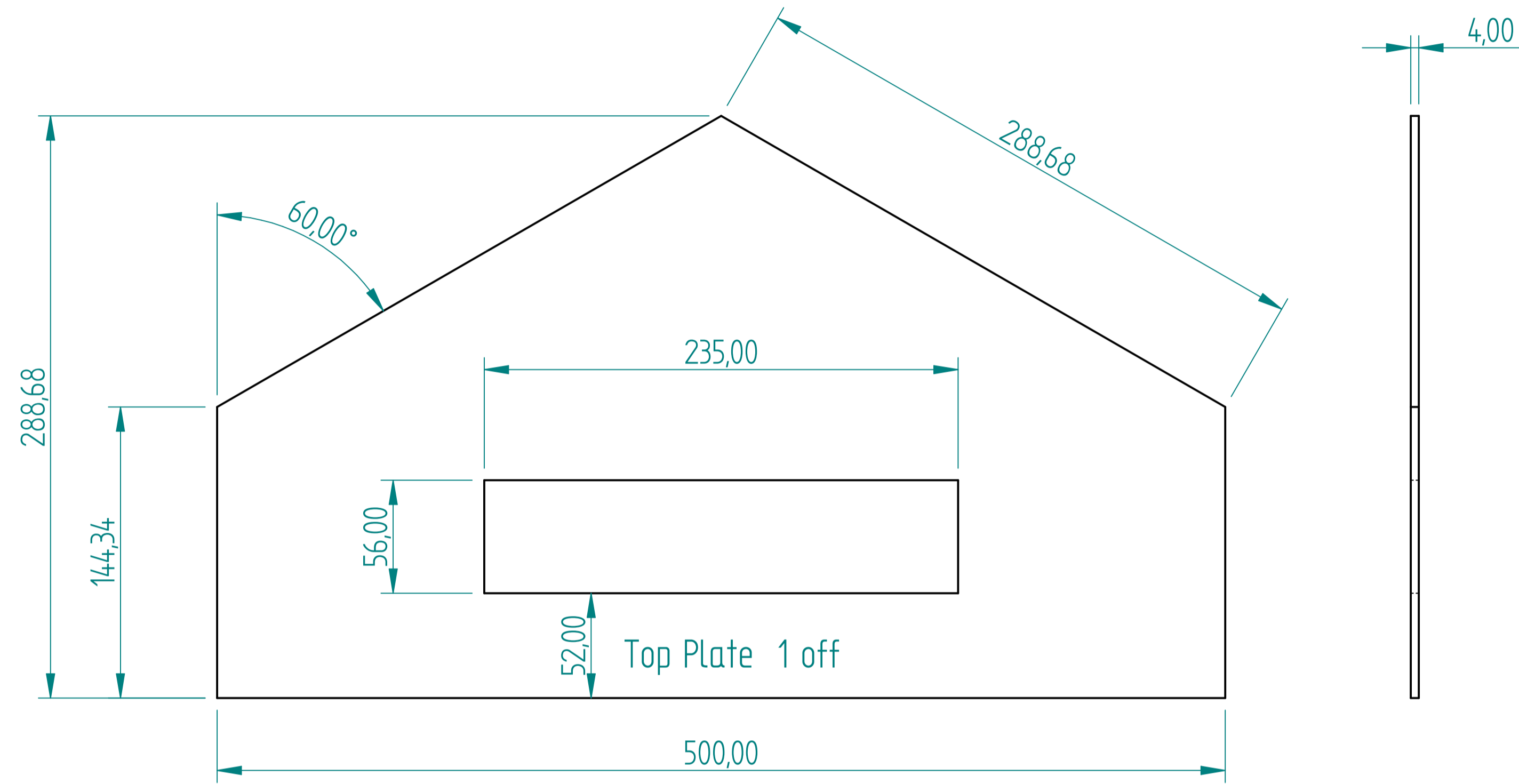

	NAME	DATE	<b>PREMAC</b>	
DRAWN	Dan	08/10/23		
APPROVED			TITLE	
MATERIAL				
TREATMENT			SIZE	DWG NO
UNLESS OTHERWISE SPECIFIED DIMENSIONS ARE IN MILLIMETERS ANGLES ±0.1°			A4	
2 PL ±0.02 3 PL ±0.005			FILE NAME: Shot Blaster.dft	REV
			SCALE:	WEIGHT:
			SHEET 3 OF 12	

REVISION HISTORY			
REV	DESCRIPTION	DATE	APPROVED

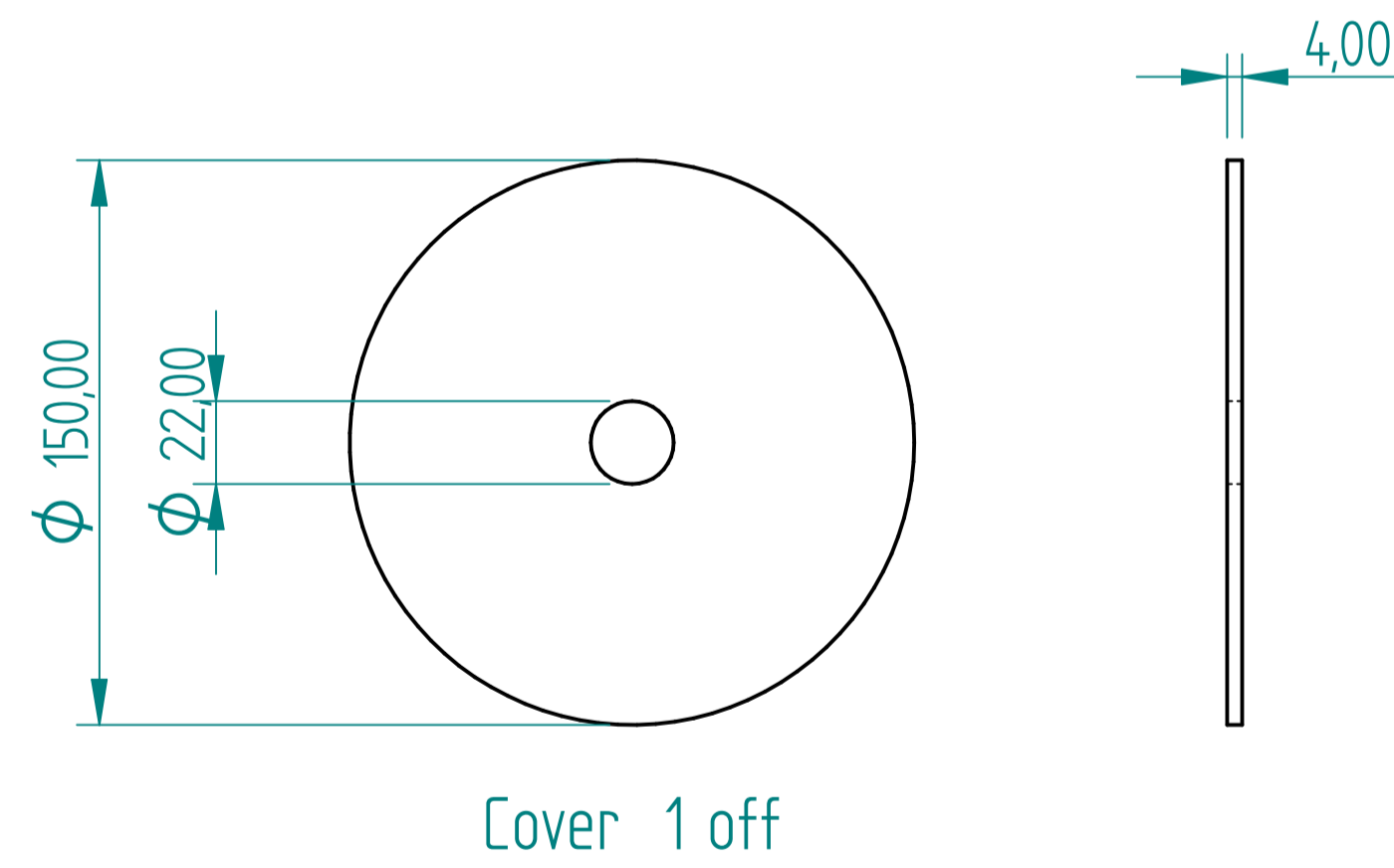
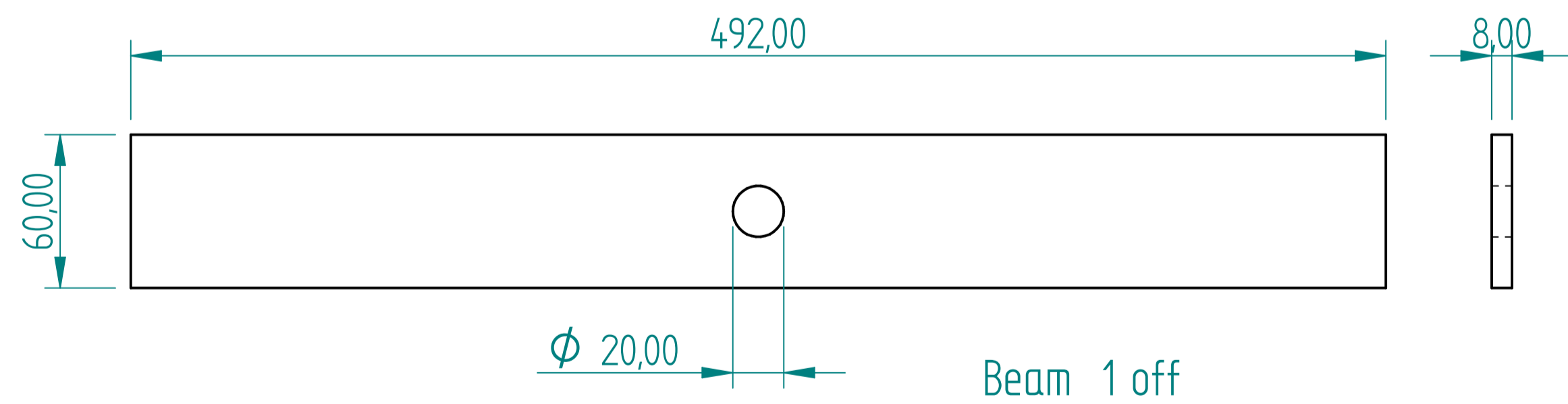
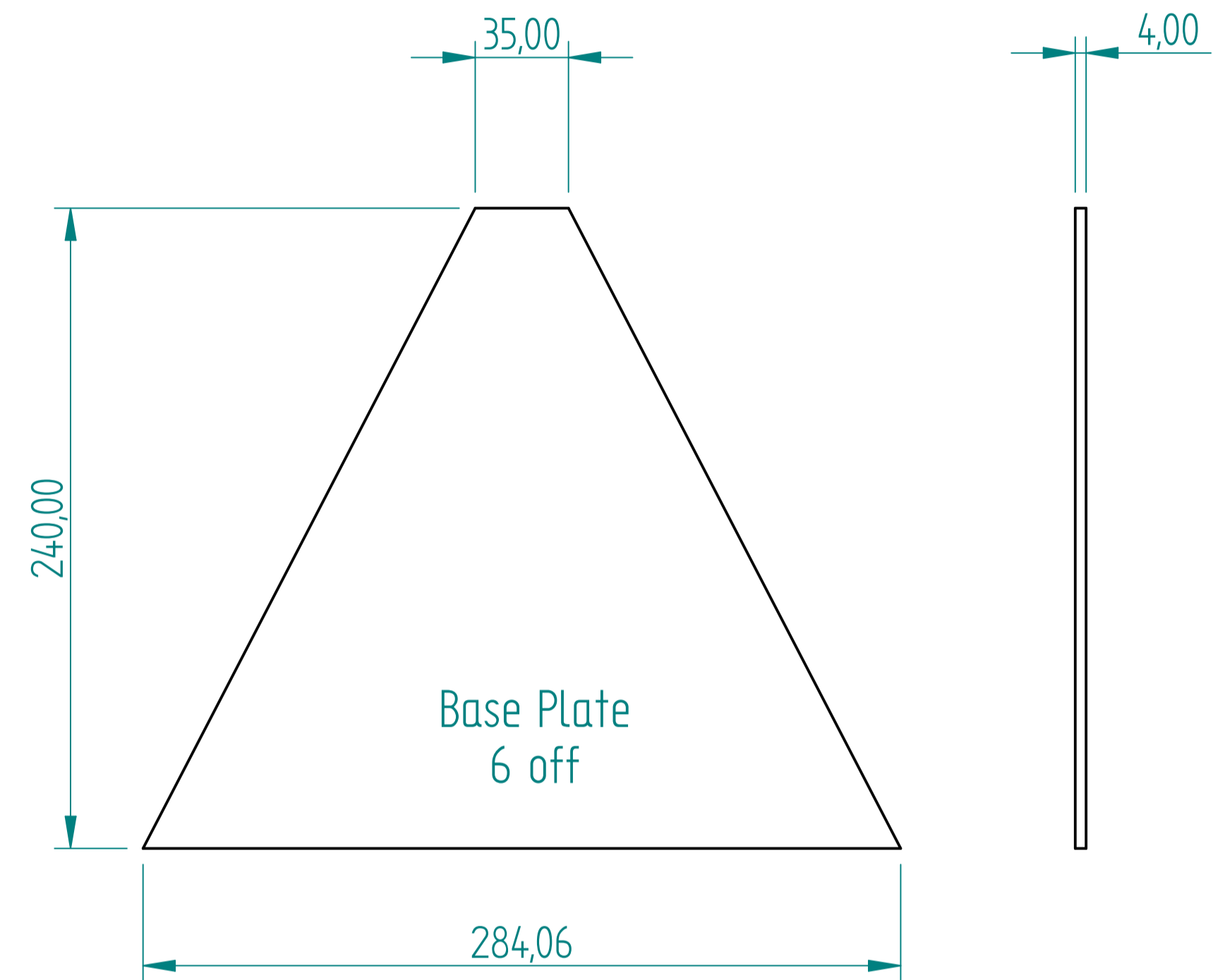
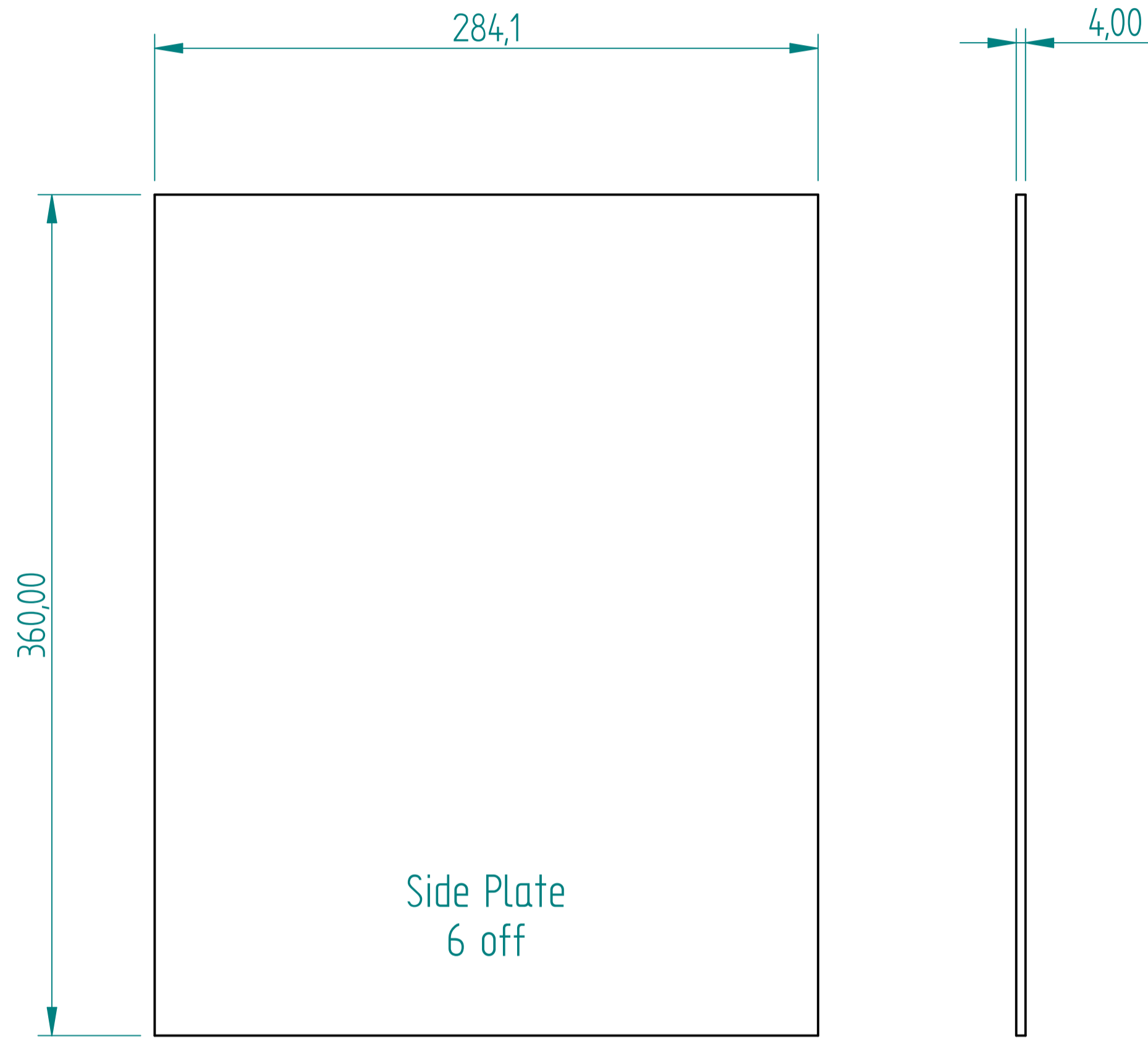

DRAWN	NAME	DATE	<b>PREMAC</b>	
APPROVED	Dan	08/10/23		
MATERIAL				
TREATMENT				
UNLESS OTHERWISE SPECIFIED DIMENSIONS ARE IN MILLIMETERS ANGLES ±0.1°			SIZE A4	DWG NO
2 PL ±0.02 3 PL ±0.005			FILE NAME: Shot Blaster.dft	REV
			SCALE:	WEIGHT:
			SHEET 4 OF 12	

REVISION HISTORY			
REV	DESCRIPTION	DATE	APPROVED

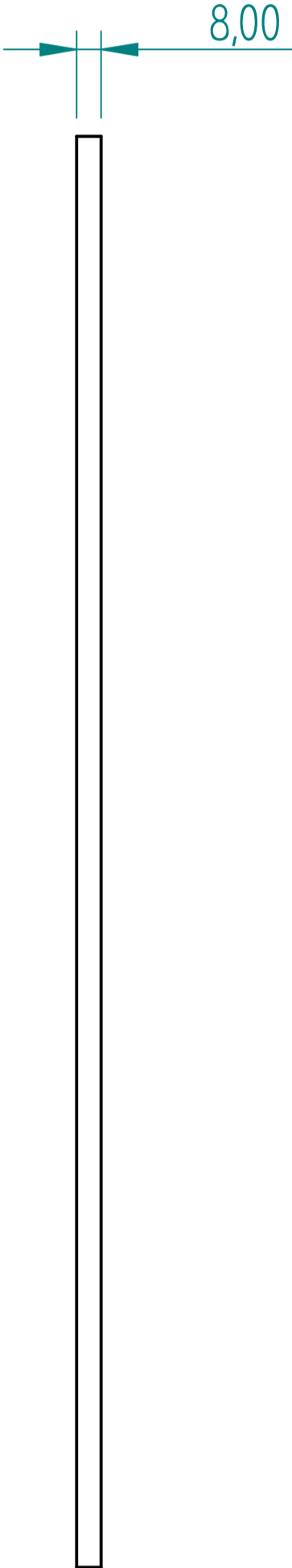
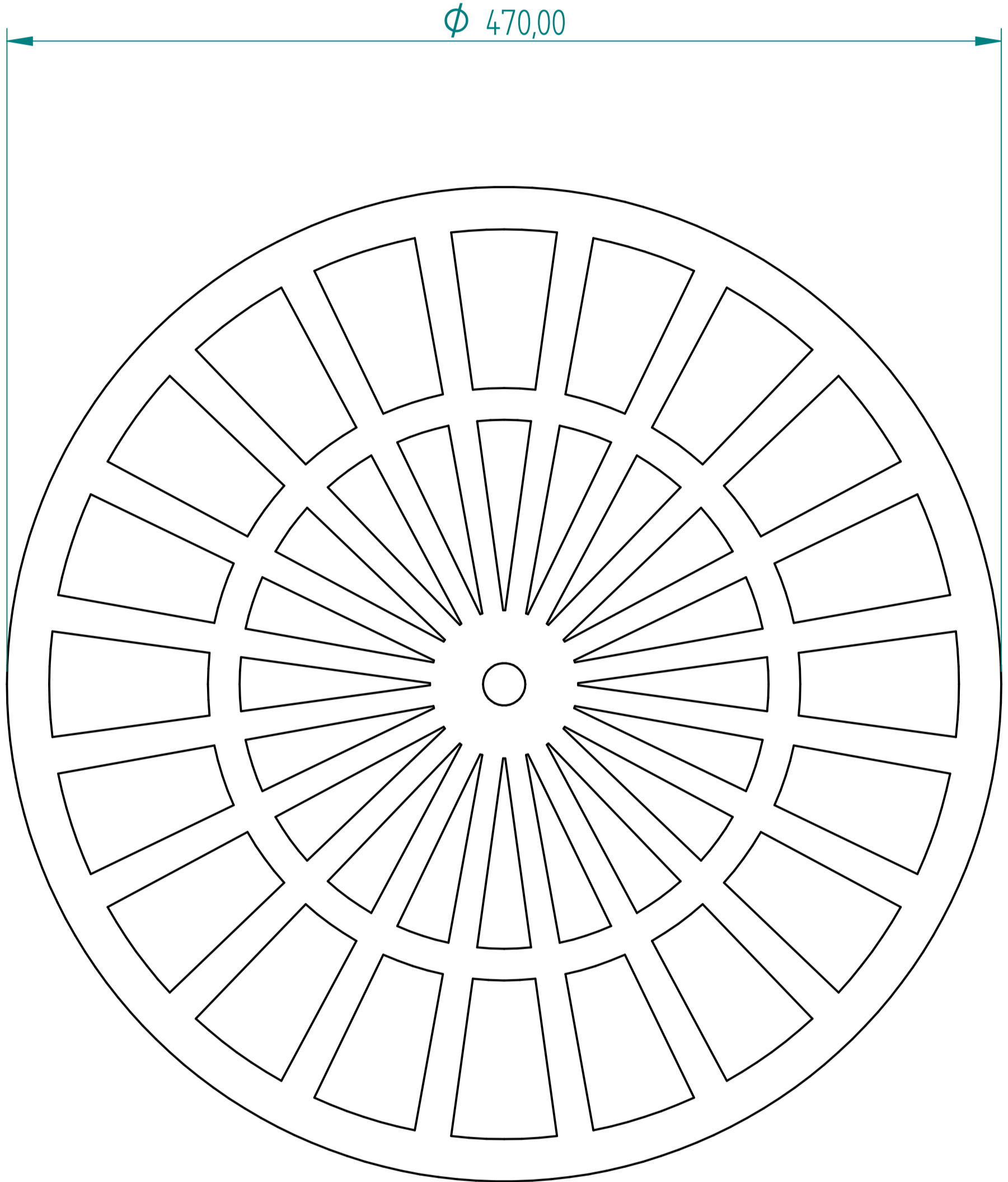

Table Base  
1 off

	NAME	DATE	<b>PREMAC</b>	
DRAWN	Dan	08/10/23		
APPROVED			TITLE	
MATERIAL				
TREATMENT				
UNLESS OTHERWISE SPECIFIED DIMENSIONS ARE IN MILLIMETERS ANGLES $\pm 0.1^\circ$			SIZE A4	DWG NO 
2 PL $\pm 0.02$ 3 PL $\pm 0.005$			FILE NAME: Shot Blaster.dft	REV 
			SCALE:	WEIGHT: SHEET 5 OF 12