

REVISION HISTORY			
REV	DESCRIPTION	DATE	APPROVED

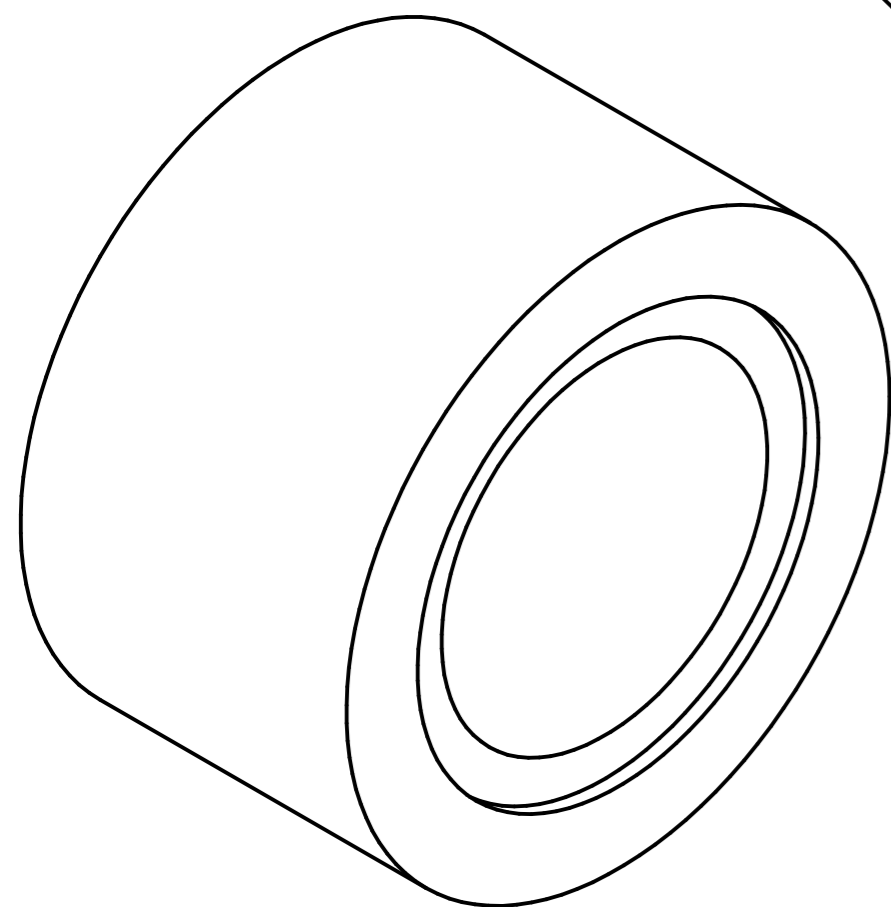
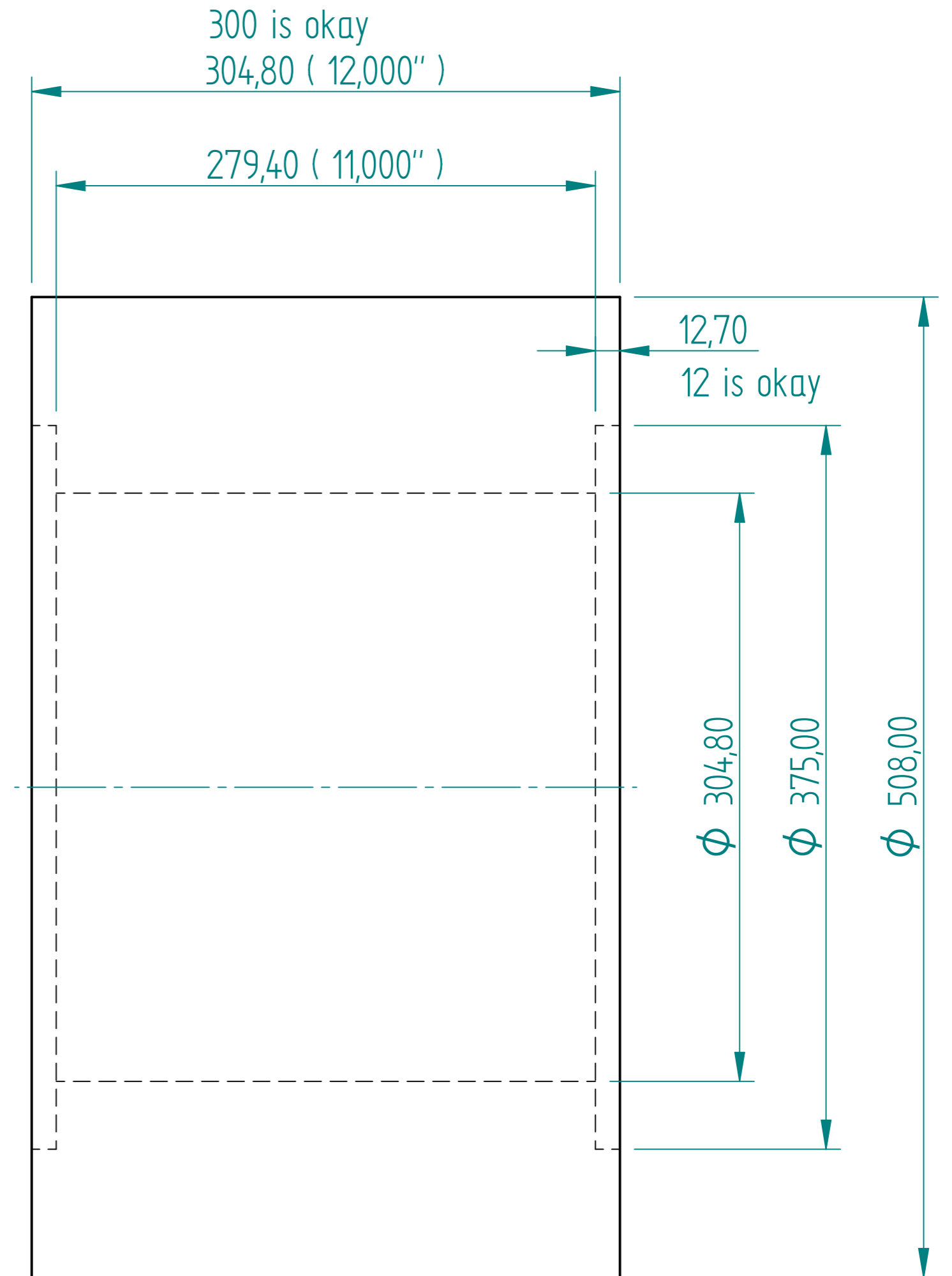
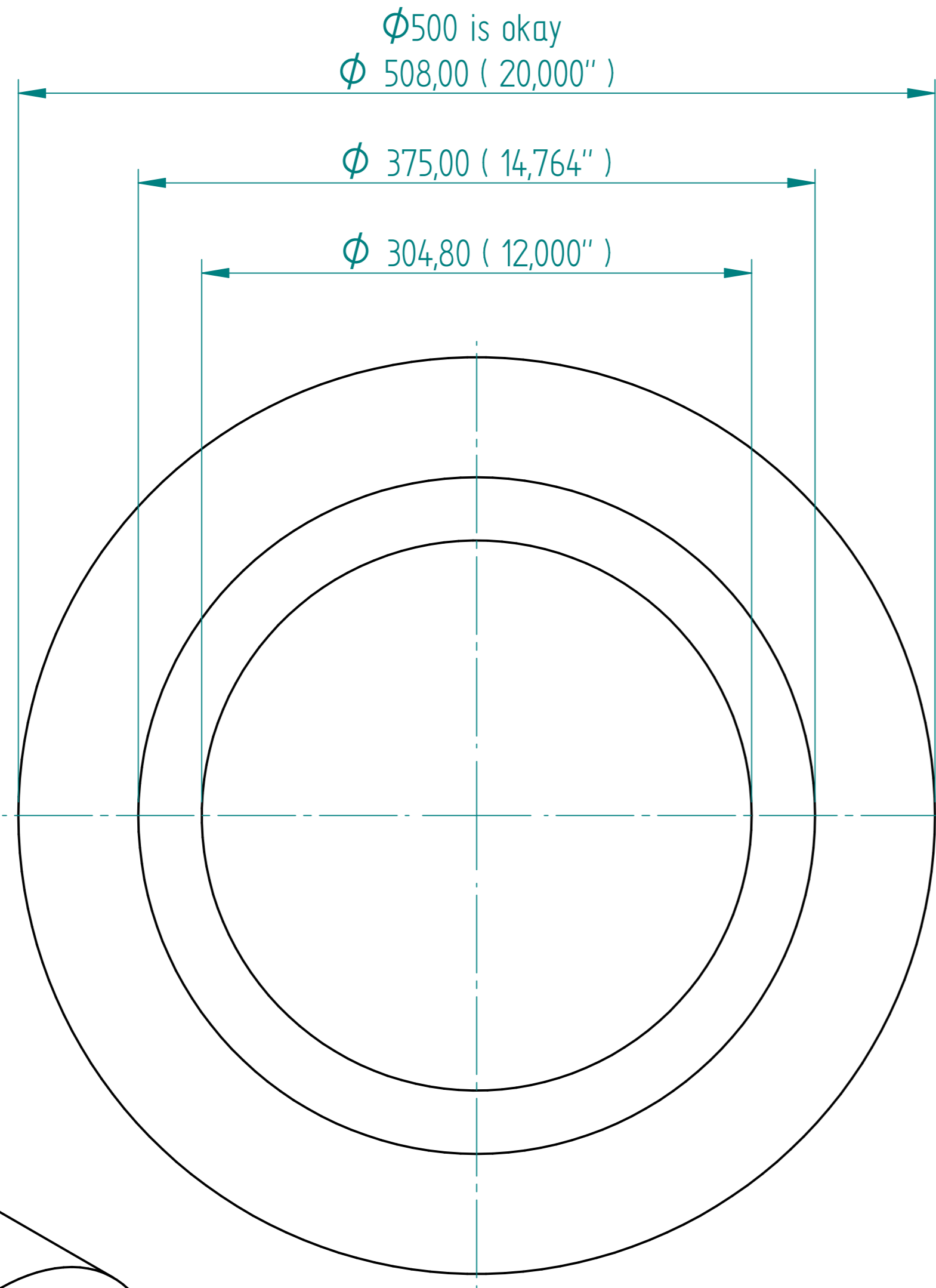

CENTRELESS GRINDING WHEEL  
 For Grinding Steel and Hard Chrome Plated Spools 69Hrc  
 508x304,8x304,8-375x12.7 Type-7  
 BAS60K7V

	NAME	DATE	<b>PREMAC</b>	
DRAWN	Dan	08/10/22		
APPROVED				
MATERIAL				
TREATMENT			TITLE	
UNLESS OTHERWISE SPECIFIED DIMENSIONS ARE IN MILLIMETERS			SIZE	DWG NO
1 <sup>ST</sup> ANGLE			A4	
2 PL ±0.02 3 PL ±0.005			FILE NAME: Centerless Wheel.dft	REV
			SCALE:	WEIGHT:
			SHEET 1 OF 1	