

REVISION HISTORY			
REV	DESCRIPTION	DATE	APPROVED

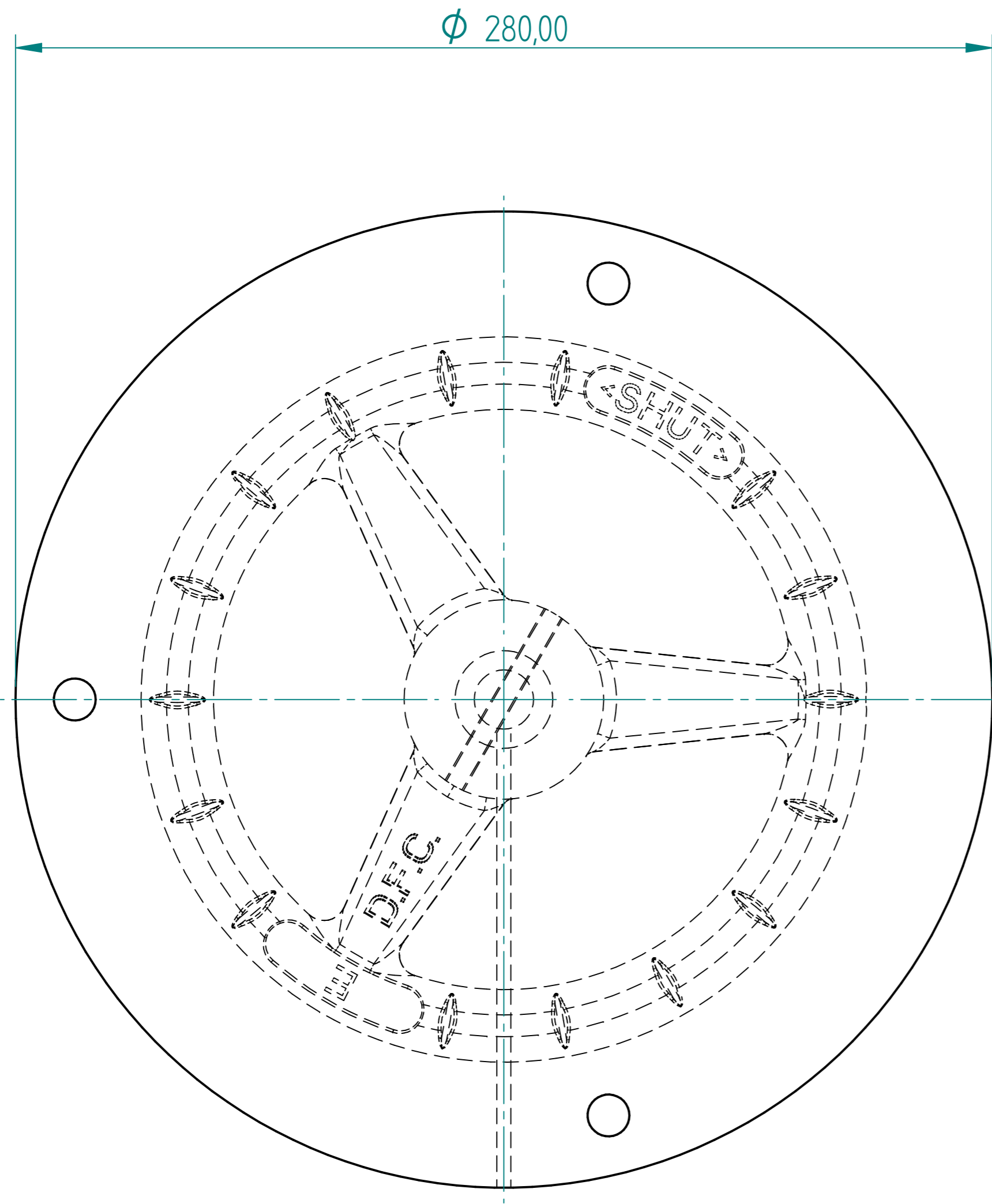

IH200RDS Mould

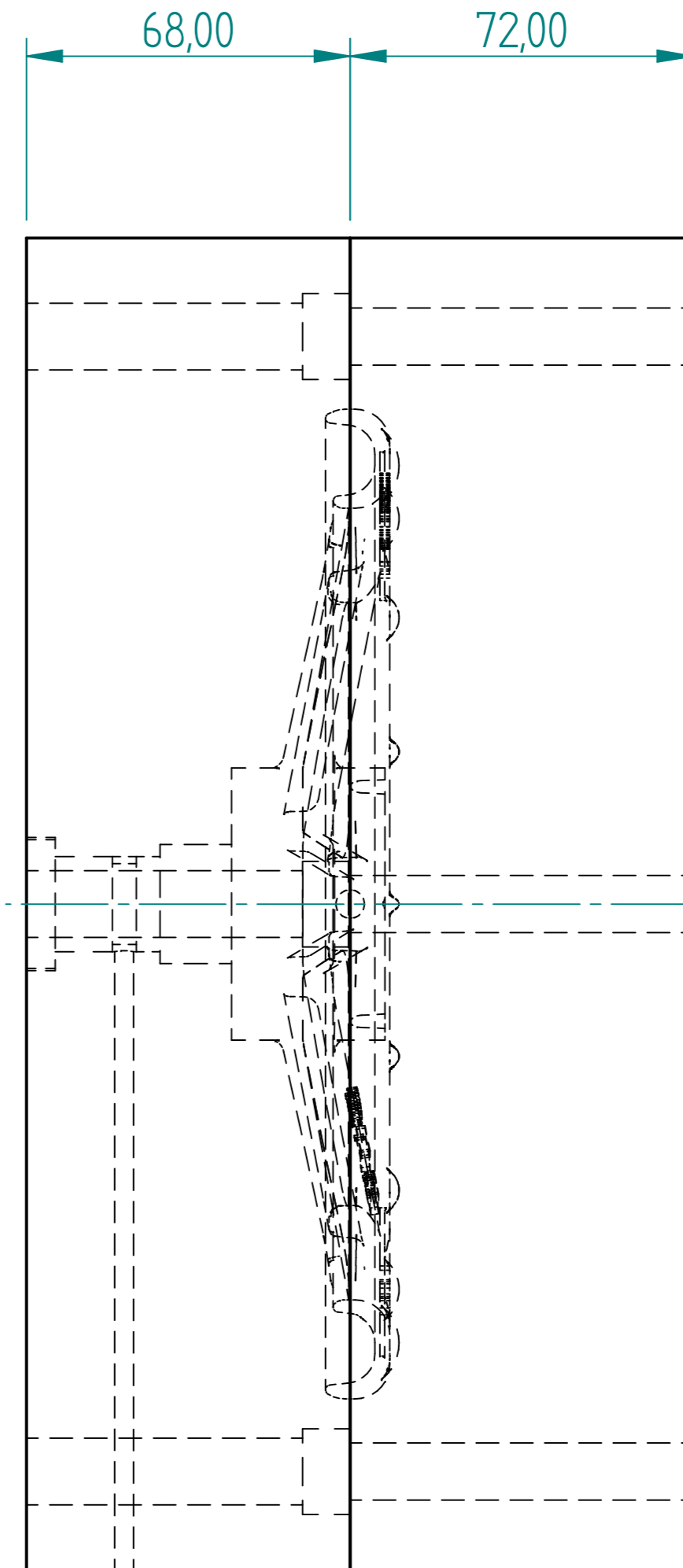

DRAWN	NAME	DATE	<b>PREMAC</b>		
APPROVED	Dan	06/03/21			
MATERIAL					
TREATMENT					
UNLESS OTHERWISE SPECIFIED DIMENSIONS ARE IN MILLIMETERS ANGLES ±0.1°			SIZE A4	DWG NO	REV
1st ANGLE 2 PL ±0.02 3 PL ±0.005			FILE NAME: IH200RDS Mould.dft		
SCALE:		WEIGHT:		SHEET 1 OF 4	

REVISION HISTORY			
REV	DESCRIPTION	DATE	APPROVED

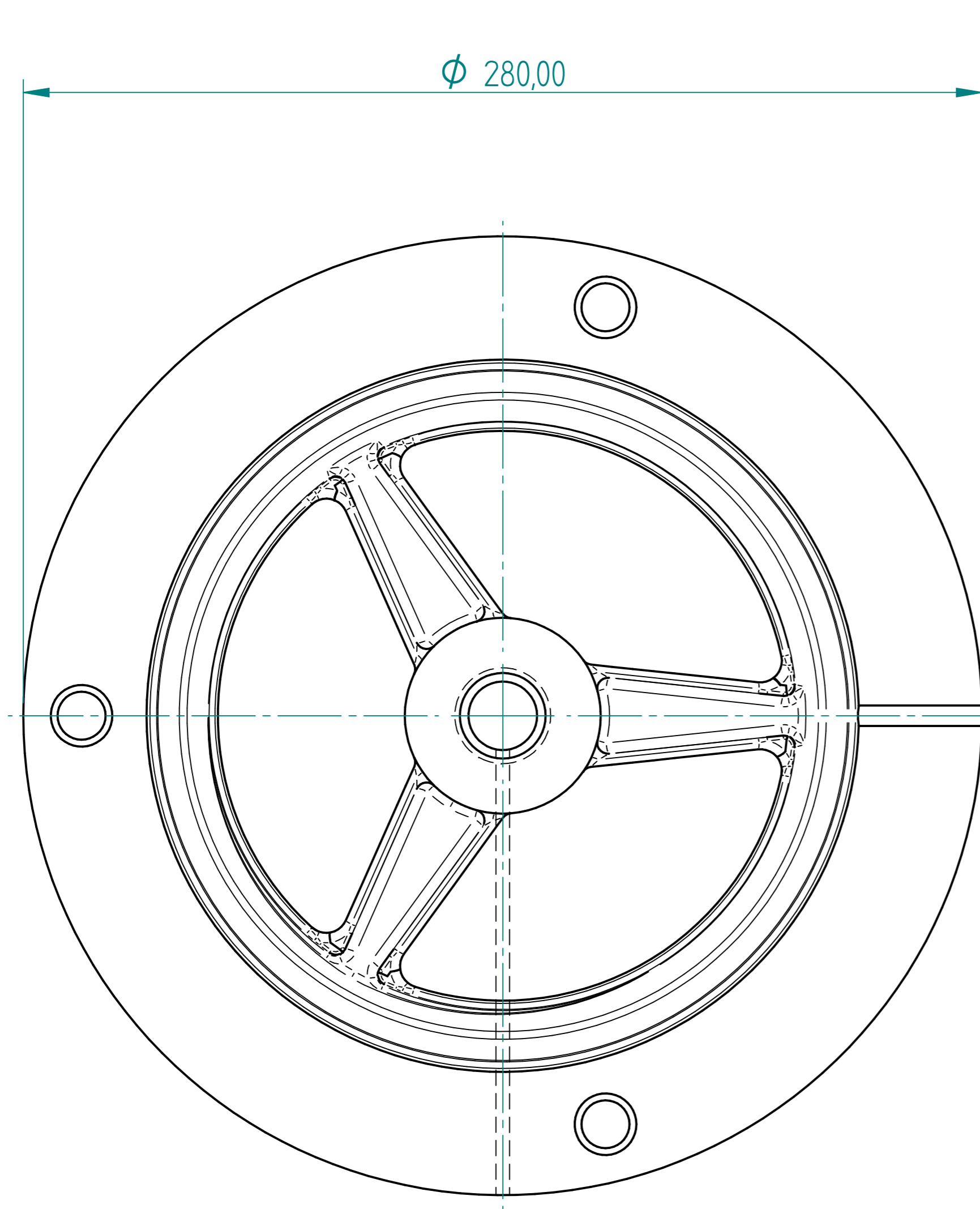

Bottom Half

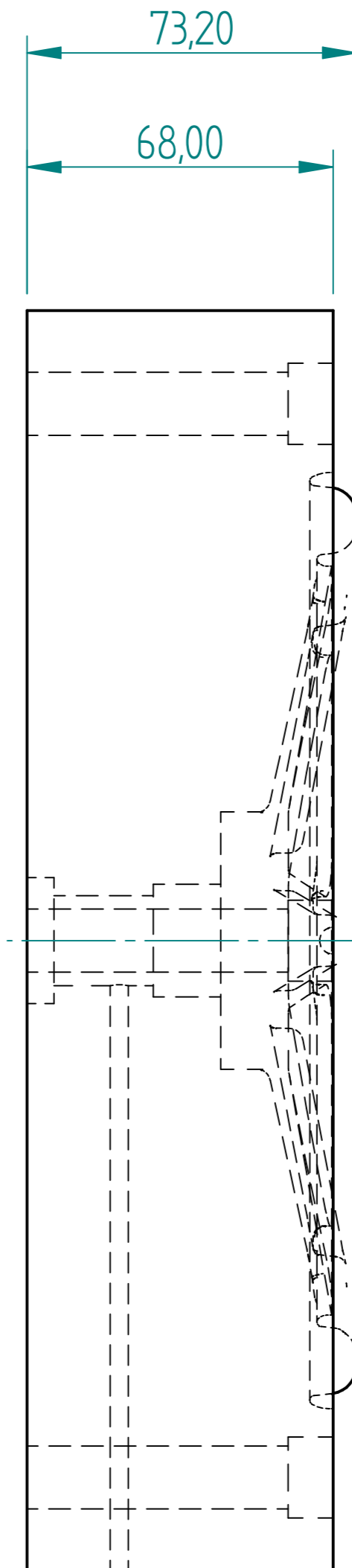

	NAME	DATE	<b>PREMAC</b>	
DRAWN	Dan	06/03/21		
APPROVED				
MATERIAL				
TREATMENT			TITLE	
			IH200RDS Mould	
UNLESS OTHERWISE SPECIFIED DIMENSIONS ARE IN MILLIMETERS			SIZE A4	DWG NO
1 <sup>ST</sup> ANGLE ANGLES ±0.1°			FILE NAME: IH200RDS Mould.dft	
2 PL ±0.02 3 PL ±0.005			SCALE:	WEIGHT:
			SHEET 2 OF 4	

REVISION HISTORY			
REV	DESCRIPTION	DATE	APPROVED

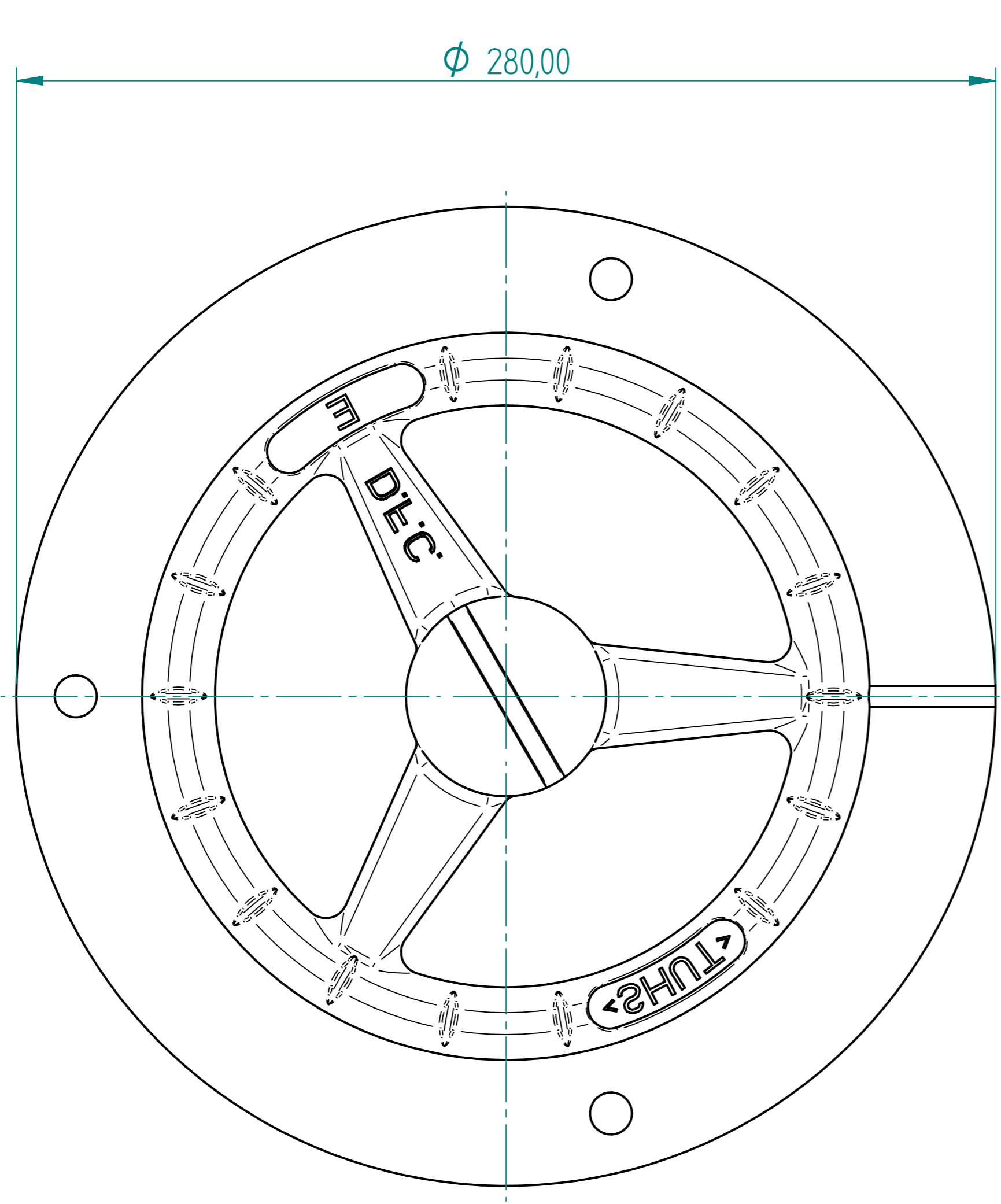

Top Half

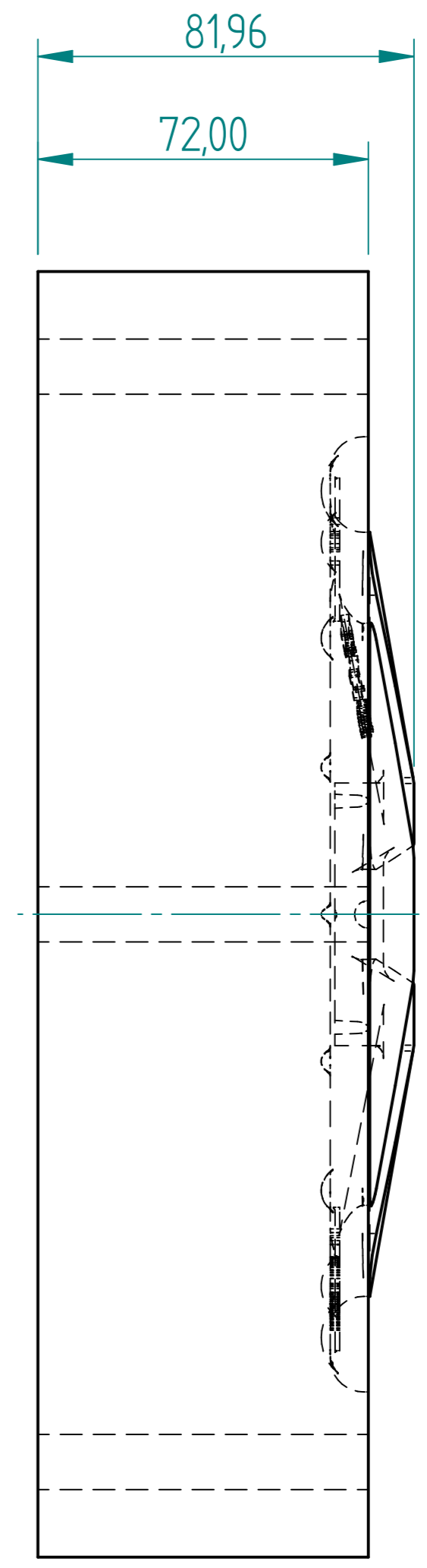

DRAWN	NAME	DATE	<b>PREMAC</b>		
APPROVED	Dan	06/03/21			
MATERIAL					
TREATMENT					
UNLESS OTHERWISE SPECIFIED DIMENSIONS ARE IN MILLIMETERS ANGLES ±0.1°			SIZE A4	DWG NO	REV
1st ANGLE 2 PL ±0.02 3 PL ±0.005			FILE NAME: IH200RDS Mould.dft		
			SCALE:	WEIGHT:	SHEET 3 OF 4

REVISION HISTORY			
REV	DESCRIPTION	DATE	APPROVED

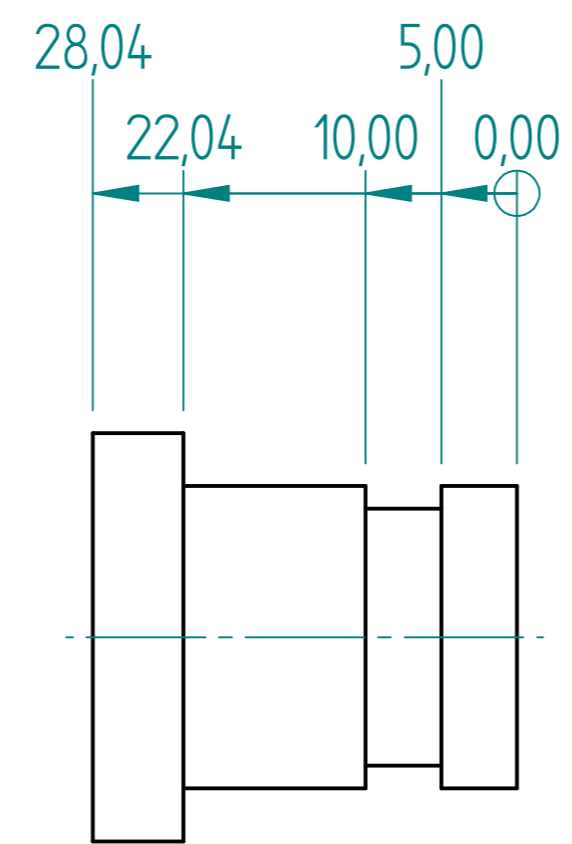
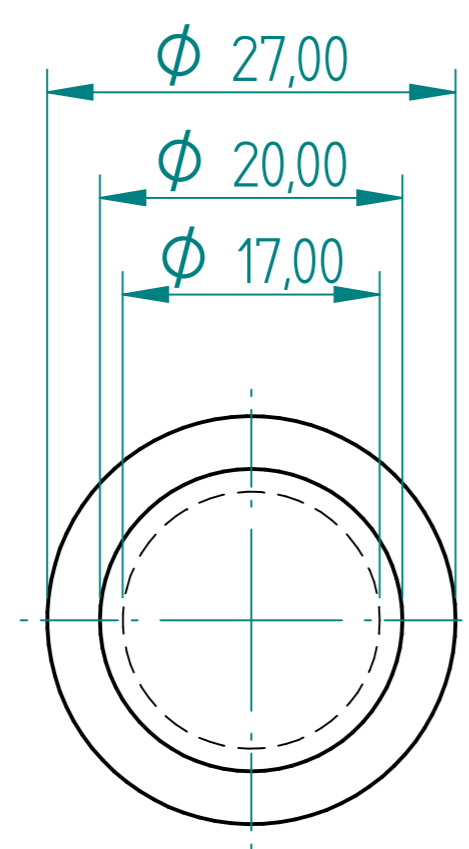

Core Pin

	NAME	DATE	<b>PREMAC</b>		
DRAWN	Dan	06/03/21			
APPROVED			TITLE IH200RDS Mould		
MATERIAL					
TREATMENT			SIZE A4	DWG NO	REV
UNLESS OTHERWISE SPECIFIED DIMENSIONS ARE IN MILLIMETERS			FILE NAME: IH200RDS Mould.dft		
1 <sup>ST</sup> ANGLE 2 PL $\pm 0,02$ 3 PL $\pm 0,005$			SCALE:	WEIGHT:	SHEET 4 OF 4